

Model	QUINTARA_DB1036L		
Creator	CHALEAMPHON	.BCP Name	INDEX_C3D_KITCHEN2
Reviewer		Order	H001527
Approves		Date	10/02/2025

QUINTARA_DB1036L-1036X580X910

Colour

05.86=ML.EARTH TISSUE AX6 (TEXTILE)

30.25=ML.HMR WHITE # AE9V (MATT) (WET PROTECT)

Edge

01.408=1 AX6



K7L-160156480



Model	-QUINTARA		
Creator	CHALEAMPHON	.BCP Name	INDEX_C3D_KITCHEN2
Reviewer		Order	H001527
Approves		Date	10/02/2025

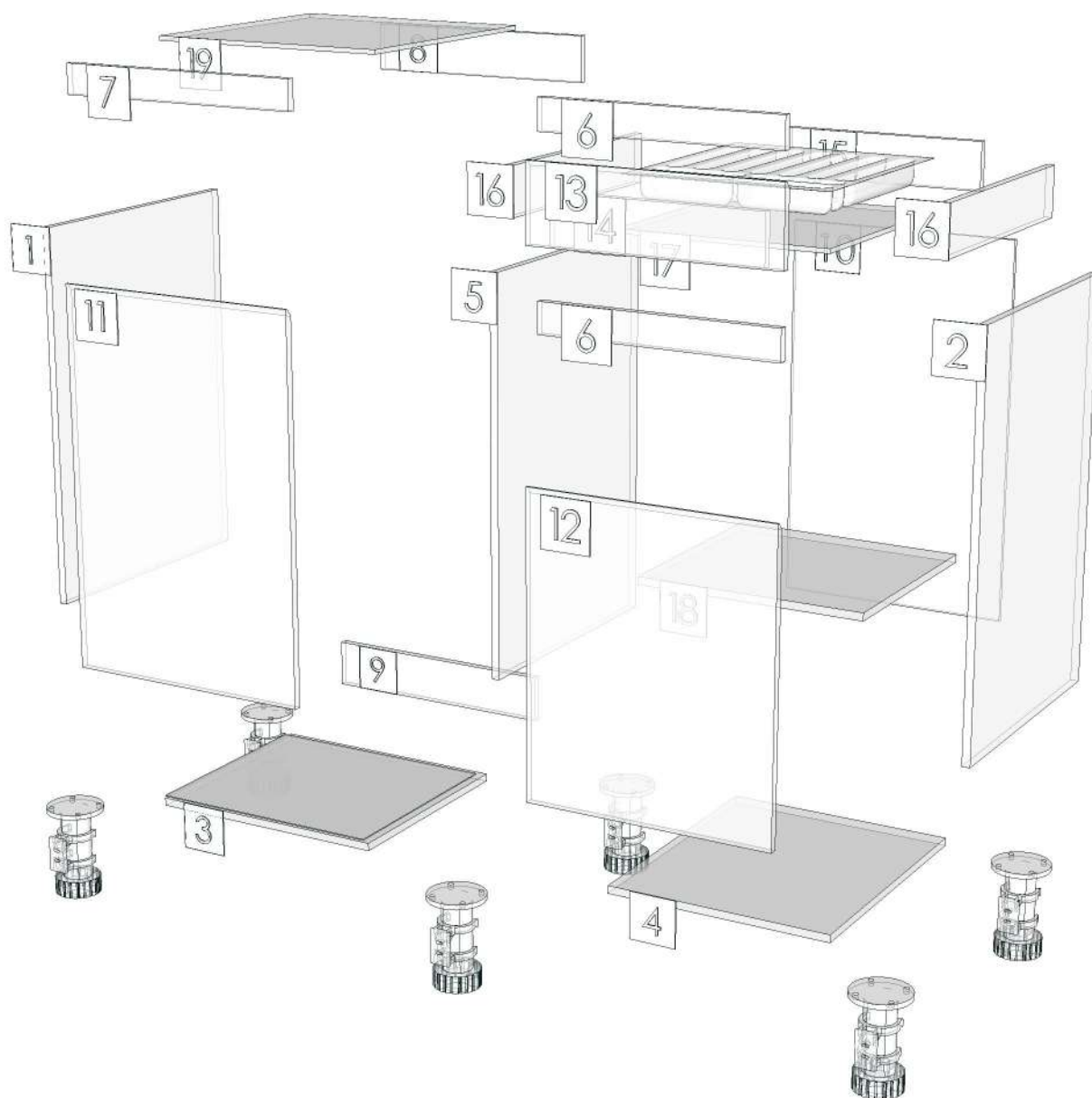

Model	QUINTARA_DBO666R		
Creator	CHALEAMPHON	.BCP Name	INDEX_C3D_KITCHEN2
Reviewer		Order	H000832
Approves		Date	14/02/2024

QUINTARA_DBO666R-666X580X910

Colour

05.86=ML.EARTH TISSUE AX6 (TEXTILE)

30.25=ML.HMR WHITE # AE9V (MATT) (WET PROTECT)

Edge

01.408=1 AX6



K1L-160134919

K3L-160140996

K10R-160148433

K2L-160156439

K4L-160156455

K7L-160156480

K21L-160156542

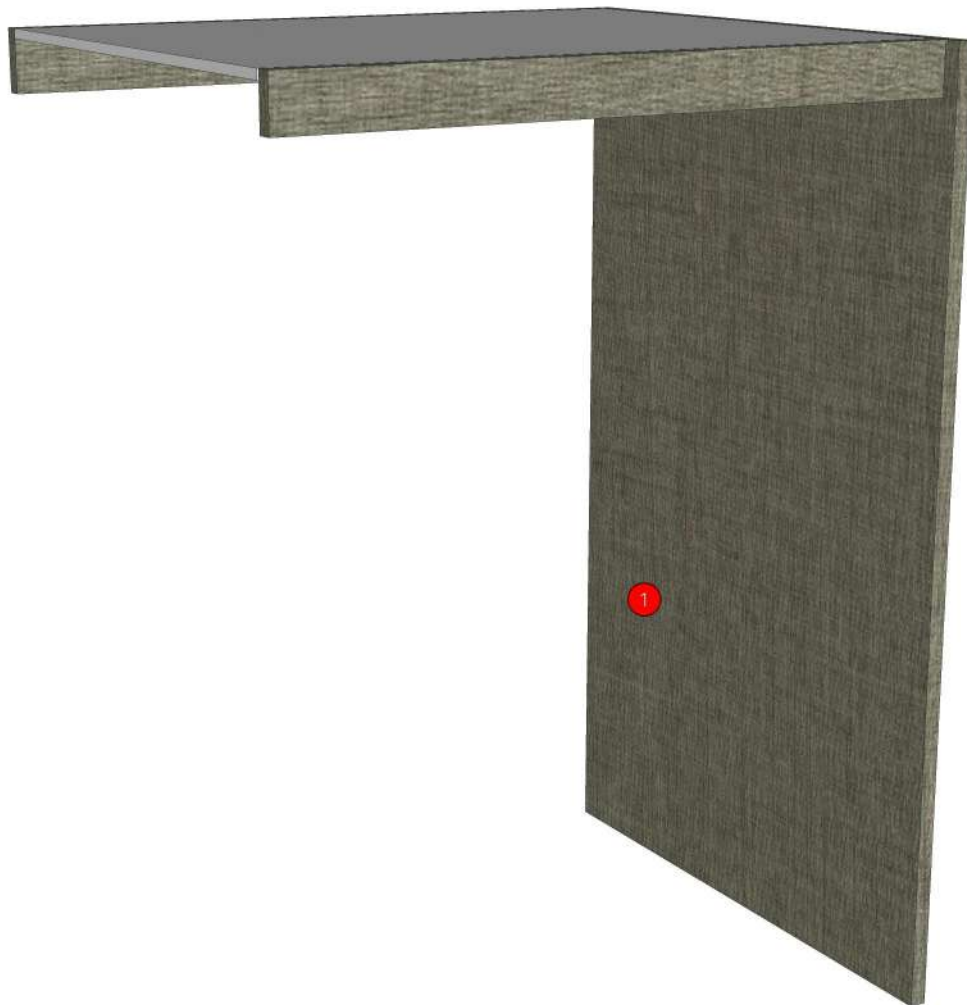

Model	-QUINTARA		
Creator	CHALEAMPON	.BCP Name	INDEX_C3D_KITCHEN2
Reviewer		Order	H000832
Approves		Date	14/02/2024

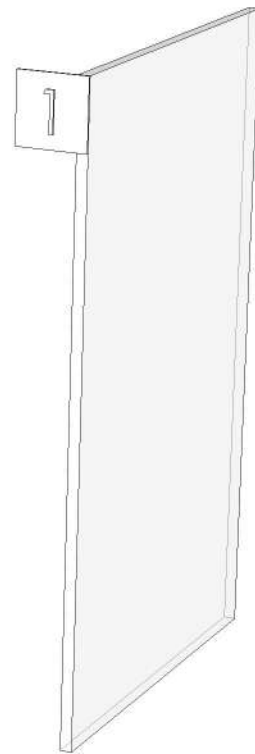
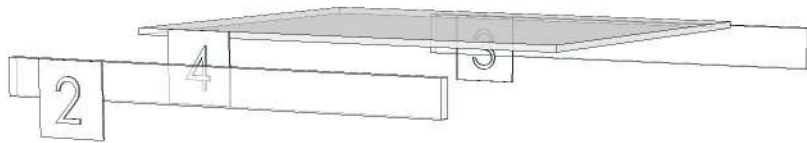

Model	QUINTARA_DDM_1070		
Creator	CHALEAMPON	.BCP Name	INDEX_C3D_KITCHEN2
Reviewer		Order	H001556
Approves		Date	27/02/2025

QUINTARA_DDM_1070-1070X16X350

Colour

05.86=ML.EARTH TISSUE AX6 (TEXTILE)

Edge

01.408=1 AX6



K7L-160156480

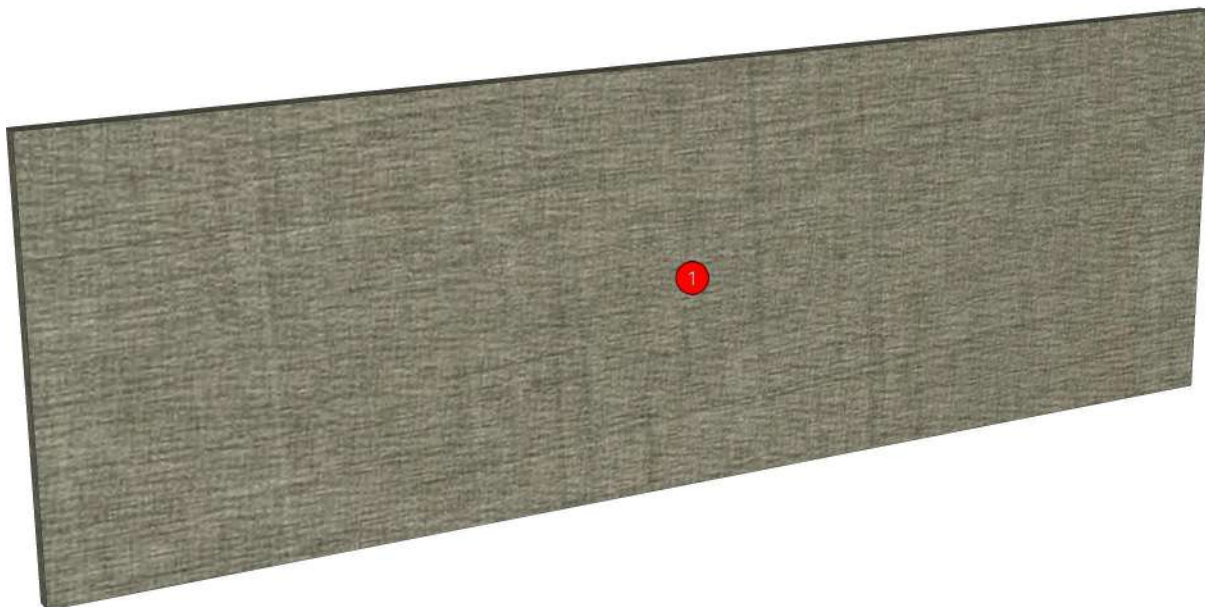

Model	QUINTARA_DDM_1070		
Creator	CHALEAMPHON	.BCP Name	INDEX_C3D_KITCHEN2
Reviewer		Order	H001556
Approves		Date	27/02/2025

No.	Article No.	Description	Mat	Dimension	Cutting Size	Typepology	Skin
0	QUINTARA_DDM_1070			1070x350x16			
	QUINTARA_DDM_1070-01	WALL	PB-SP	16x350x1070	16X348X1068;L2:W2	183000_STR=05.86_EDG=AX6-1	2

Model	QUINTARA_DFB		
Creator	CHALEAMPHON	.BCP Name	INDEX_C3D_KITCHEN2
Reviewer		Order	H000842
Approves		Date	17/02/2024

QUINTARA_DFB-150X580X810

Colour

05.86=ML.EARTH TISSUE AX6 (TEXTILE)

Edge

01.408=1 AX6



- K3L-160140996
- K6R-160141005
- K8R-160134928
- K9L-160148447
- K10R-160148433
- K14L-160141014
- K14R-160134940
- K7L-160156480
- K11R-160156489
- K12R-160156505
- K13R-160156520
- K22L-1601

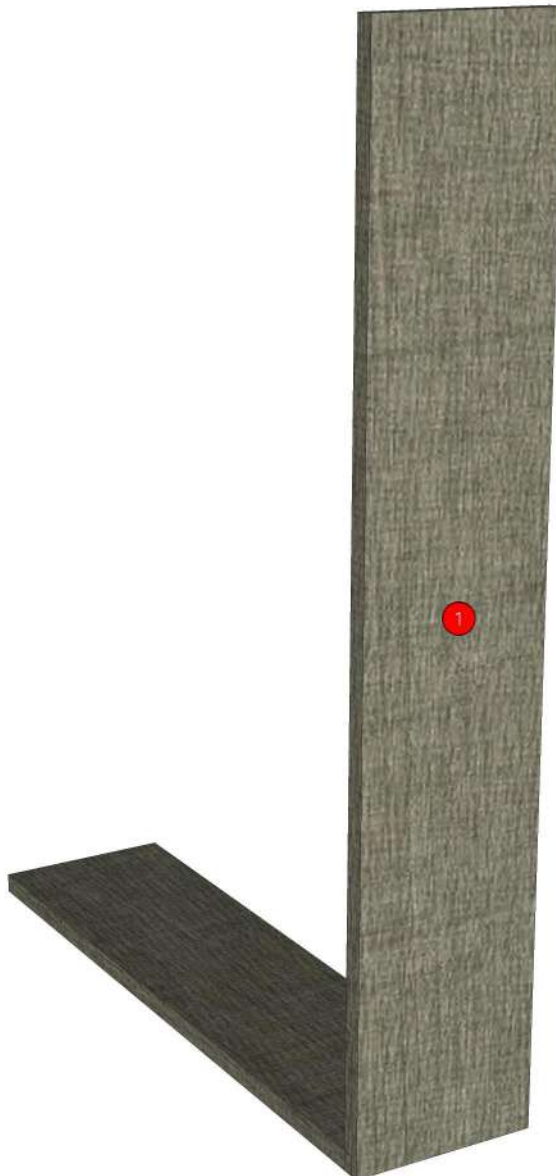

Model	-QUINTARA		
Creator	CHALEAMPON	.BCP Name	INDEX_C3D_KITCHEN2
Reviewer		Order	H000842
Approves		Date	17/02/2024

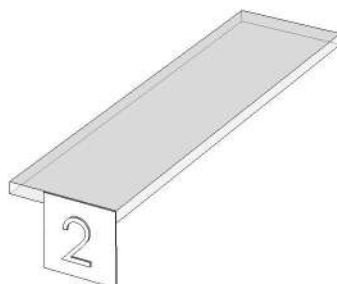
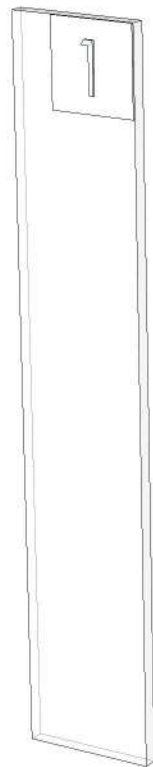

Model	QUINTARA_DFCL_1800		
Creator	CHALEAMPHON	.BCP Name	INDEX_C3D_KITCHEN2
Reviewer		Order	H001565
Approves		Date	27/02/2025

QUINTARA_DFCL_1800-1800X9X120

Colour

05.86=ML.EARTH TISSUE AX6 (TEXTILE)

Edge

01.408=1 AX6



K7L-160156480

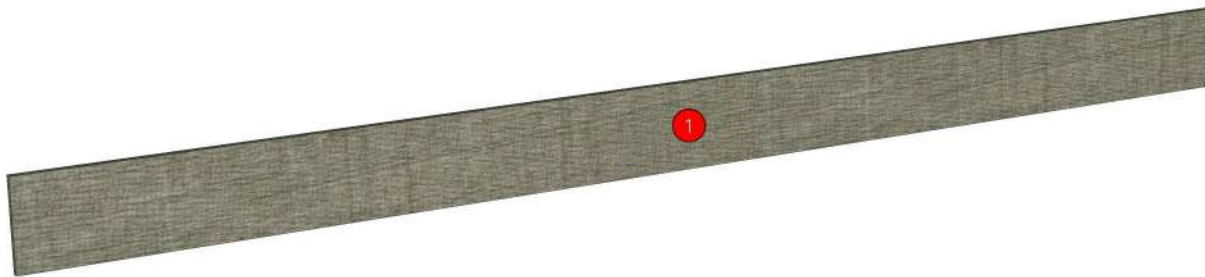

Model	QUINTARA_DFCL_1800		
Creator	CHALEAMPHON	.BCP Name	INDEX_C3D_KITCHEN2
Reviewer		Order	H001565
Approves		Date	27/02/2025

No.	Article No.	Description	Mat	Dimension	Cutting Size	Typepology	Skin
0	QUINTARA_DFCL_1800			1800x120x9			
	QUINTARA_DFCL_1800-01	FILLER TOP	PB-SP	9x120x1800	9X119X1799;L1:W1	183000_STR=05.86_EDG=AX6-1	2

Model	QUINTARA_DFCL_320		
Creator	CHALEAMPHON	.BCP Name	INDEX_C3D_KITCHEN2
Reviewer		Order	H000849
Approves		Date	17/02/2024

QUINTARA_DFCL_320-320X9X120

Colour

05.86=ML.EARTH TISSUE AX6 (TEXTILE)

Edge

01.408=1 AX6



- K1L-160134919
- K1R-160140987
- K6R-160141005
- K8R-160134928
- K9L-160148447
- K10R-160148433
- K14L-160141014
- K14R-160134940
- K15R-160141023
- K2L-160156439
- K2R-160156447
- K4L-160156455
- K4R-160156463
- K5R-160156471
- K7L-160156480
- K11R-160156489
- K12R-160156505
- K13R-160156520
- K21L-160156542
- K21R-160156551

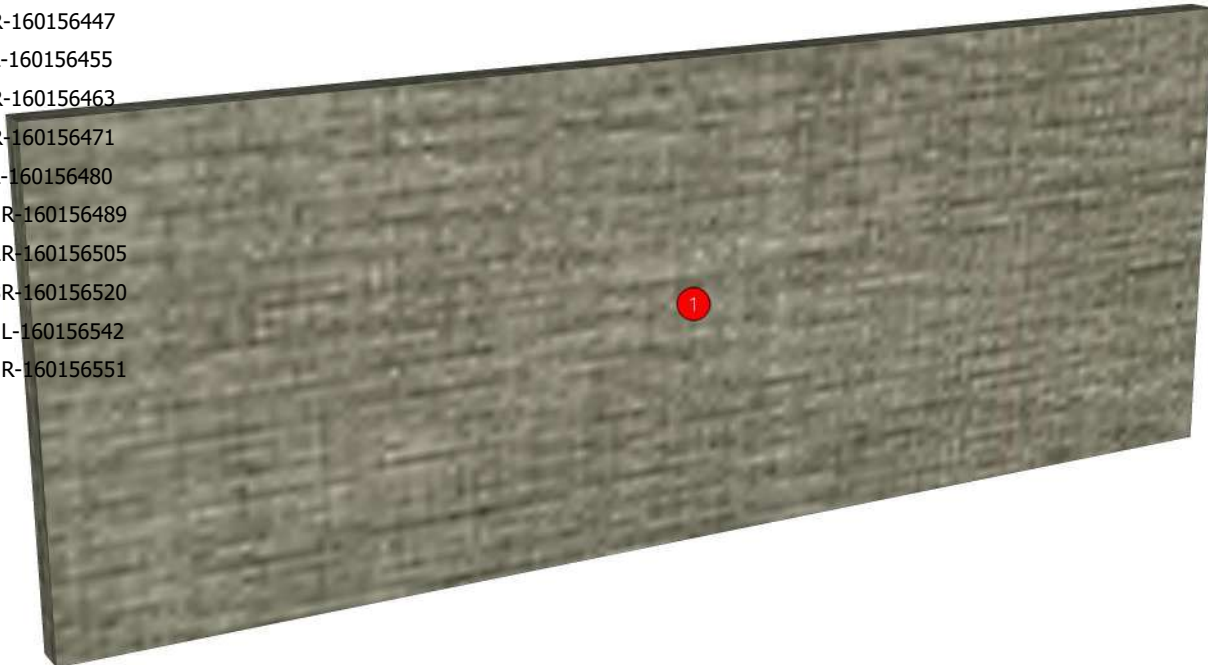

Model	QUINTARA_DFCL_320		
Creator	CHALEAMPHON	.BCP Name	INDEX_C3D_KITCHEN2
Reviewer		Order	H000849
Approves		Date	17/02/2024

No.	Article No.	Description	Mat	Dimension	Cutting Size	Typepology	Skin
0	QUINTARA_DFCL_320			320x120x9			
	QUINTARA_DFCL_320-01	FILLER TOP	PB-SP	9x120x320	9X119X319;L1:W1	183000_STR=05.86_EDG=AX6-1	2

Model	QUINTARA_DFW		
Creator	CHALEAMPHON	.BCP Name	INDEX_C3D_KITCHEN2
Reviewer		Order	H000845
Approves		Date	17/02/2024

QUINTARA_DFW-150X320X350

Colour

05.86=ML.EARTH TISSUE AX6 (TEXTILE)

Edge

01.408=1 AX6



K3L-160140996

K8R-160134928

KK7L-160156480

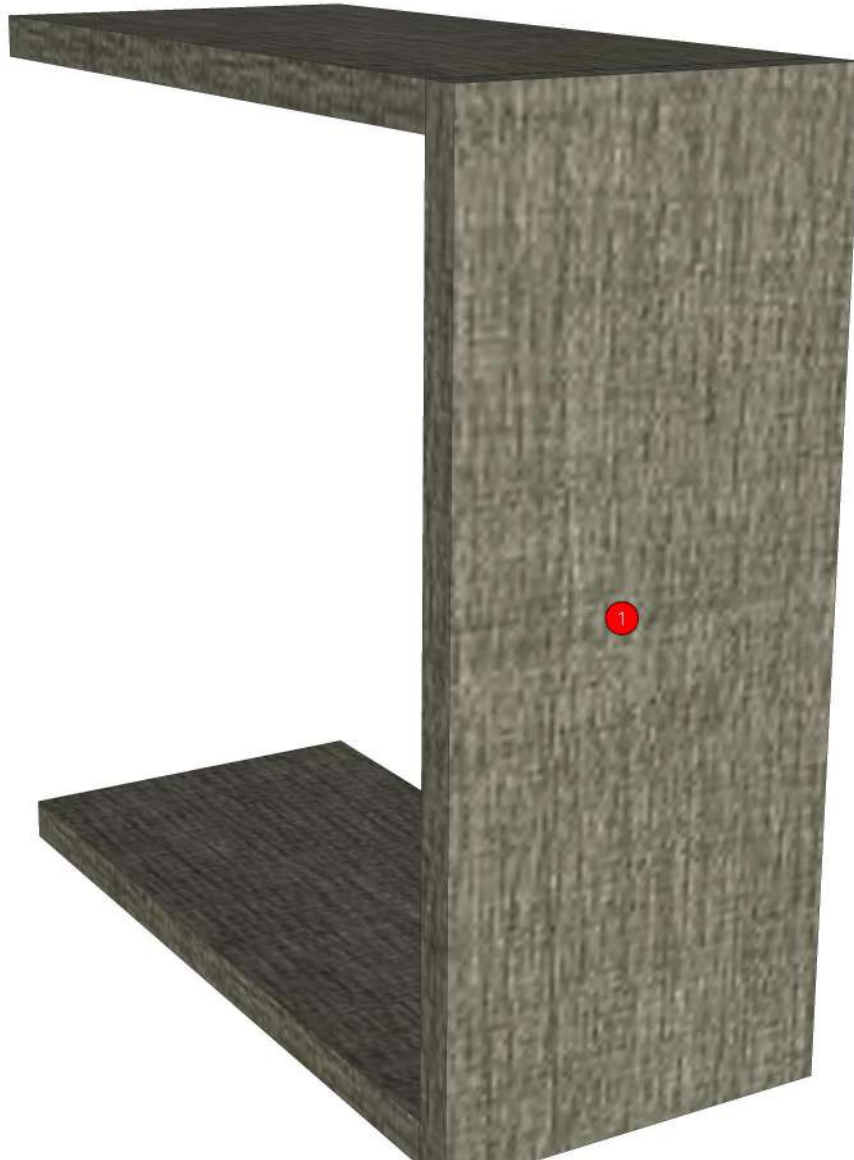

Model	-QUINTARA		
Creator	CHALEAMPHON	.BCP Name	INDEX_C3D_KITCHEN2
Reviewer		Order	H000845
Approves		Date	17/02/2024

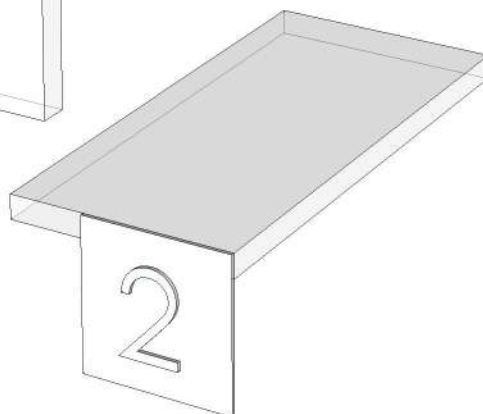
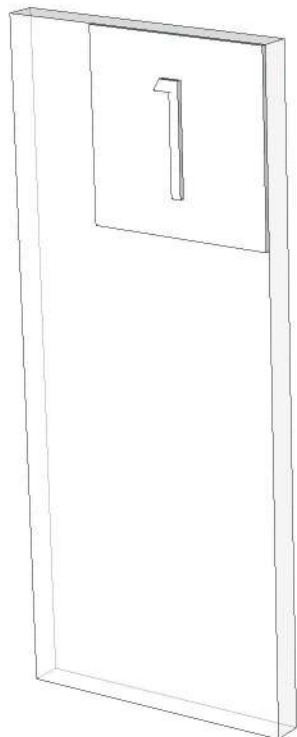
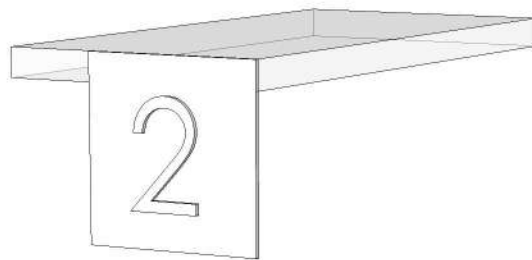

Model	QUINTARA_DL60H1R		
Creator	CHALEAMPHON	.BCP Name	INDEX_C3D_KITCHEN2
Reviewer		Order	H001548
Approves		Date	21/02/2025

QUINTARA_DL60H1R-600X320X600

Colour

05.86=ML.EARTH TISSUE AX6 (TEXTILE)

Edge

01.408=1 AX6



- K2L-160156439
- K4L-160156455
- K7L-160156480
- K11R-160156489
- K12R-160156505
- K13R-160156520
- K21L-160156542

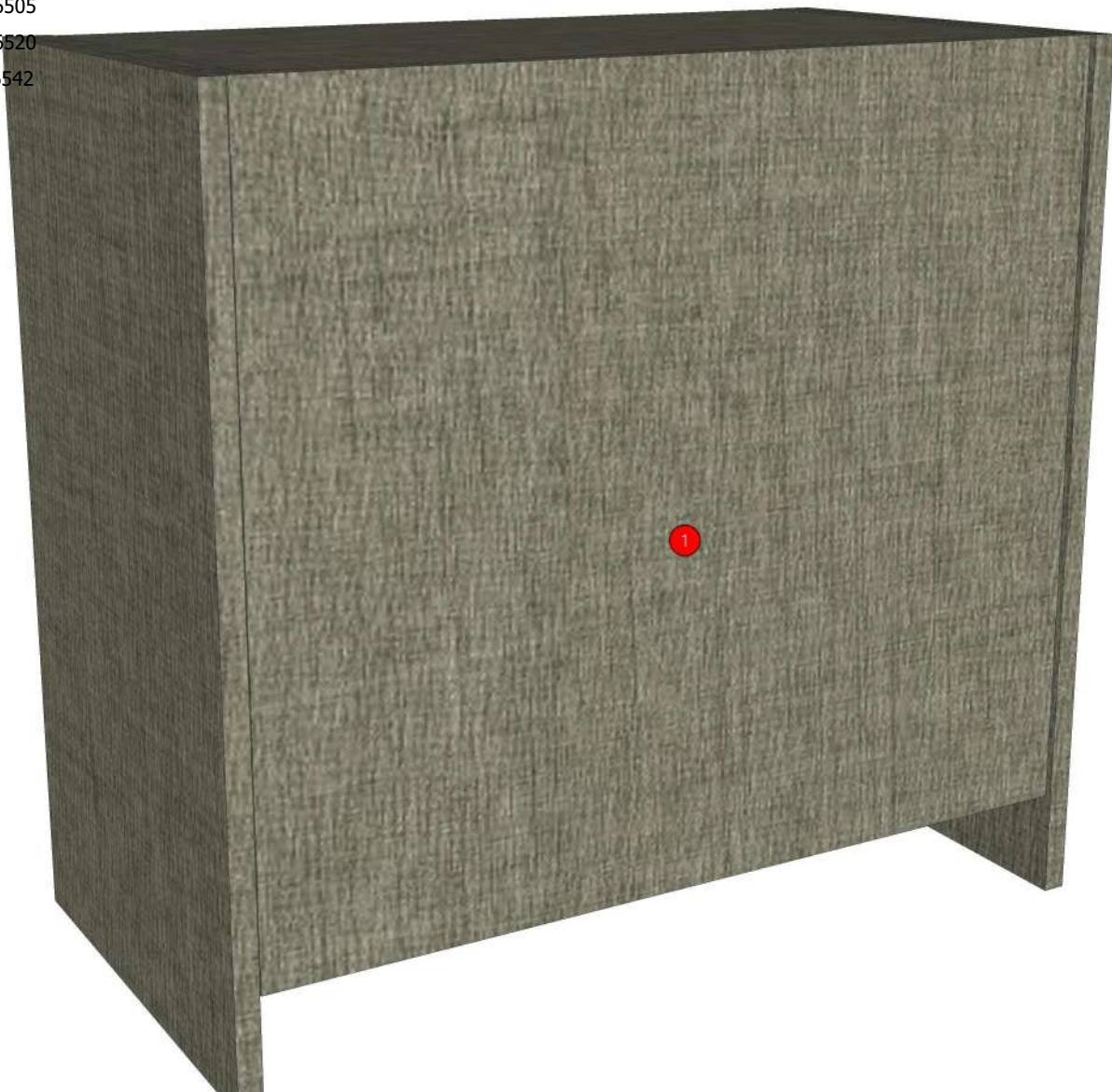

Model	-QUINTARA		
Creator	CHALEAMPHON	.BCP Name	INDEX_C3D_KITCHEN2
Reviewer		Order	H001548
Approves		Date	21/02/2025

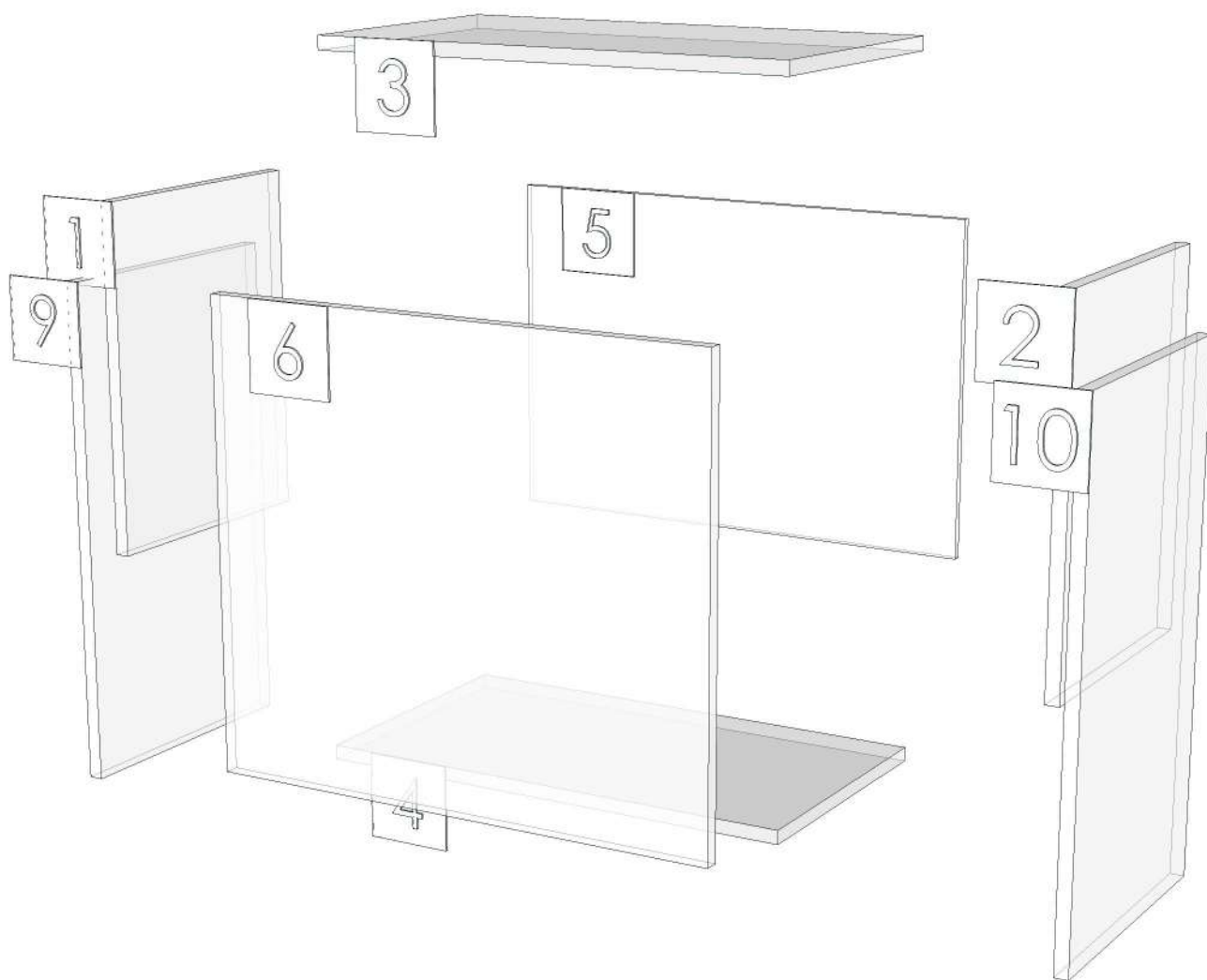

Model	QUINTARA_DPLT_1200		
Creator	CHALEAMPHON	.BCP Name	INDEX_C3D_KITCHEN2
Reviewer		Order	H001569
Approves		Date	27/02/2025

QUINTARA_DPLT_1200-1200X9X100

Colour

05.86=ML.EARTH TISSUE AX6 (TEXTILE)

Edge

01.408=1 AX6



K7L-160156480

K11R-160156489

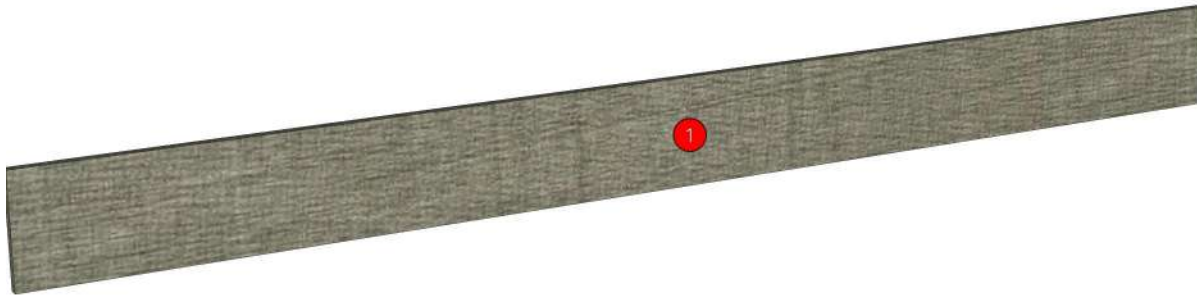

Model	QUINTARA_DPLT_1200		
Creator	CHALEAMPHON	.BCP Name	INDEX_C3D_KITCHEN2
Reviewer		Order	H001569
Approves		Date	27/02/2025

No.	Article No.	Description	Mat	Dimension	Cutting Size	Typepology	Skin
0	QUINTARA_DPLT_1200			1200x100x9			
	QUINTARA_DPLT_1200-01	LED BOTTOM	PB-SP	9x100x1200	9X98X1199;L2:W1	183000_STR=05.86_EDG=AX6-1	2

Model	QUINTARA_DPLT_600		
Creator	CHALEAMPHON	.BCP Name	INDEX_C3D_KITCHEN2
Reviewer		Order	H000851
Approves		Date	19/02/2024

QUINTARA_DPLT_600-600X9X100

Colour

05.86=ML.EARTH TISSUE AX6 (TEXTILE)

Edge

01.408=1 AX6

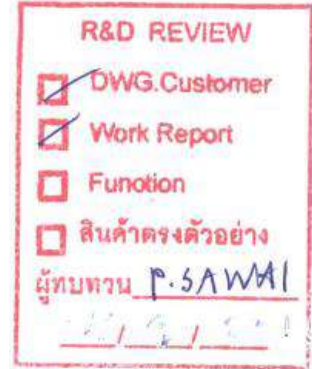

- K1L-160134919
- K1R-160140987
- K3L-160140996
- K6R-160141005
- K8R-160134928
- K9L-160148447
- K10R-160148433
- K14L-160141014
- K14R-160134940
- K15R-160141023
- K2L-160156439
- K2R-160156447
- K4L-160156455
- K4R-160156463
- K5R-160156471
- K7L-160156480
- K11R-160156489
- K12R-160156505
- K13R-160156520
- K21L-160156542
- K21R-160156551
- K22L-1601

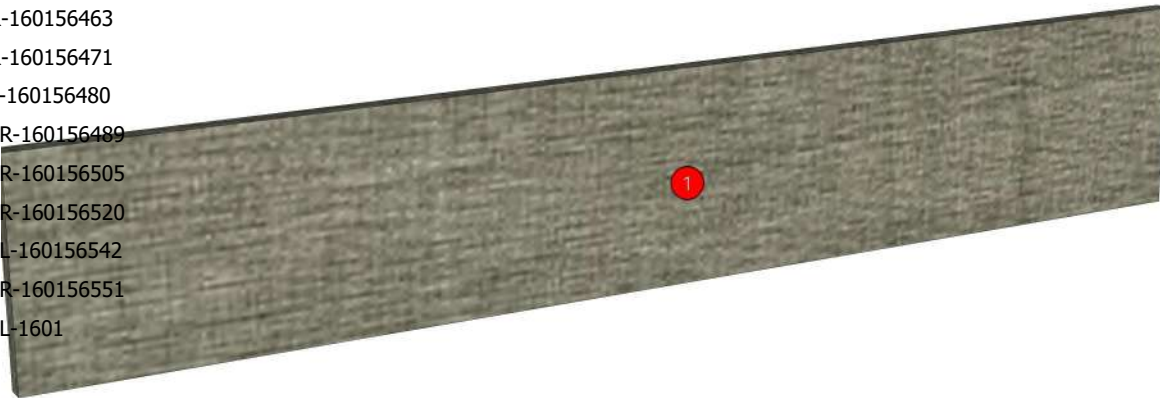

Model	QUINTARA_DPLT_600		
Creator	CHALEAMPHON	.BCP Name	INDEX_C3D_KITCHEN2
Reviewer		Order	H000851
Approves		Date	19/02/2024

No.	Article No.	Description	Mat	Dimension	Cutting Size	Typepology	Skin
0	QUINTARA_DPLT_600			600x100x9			
	QUINTARA_DPLT_600-01	LED BOTTOM	PB-SP	9x100x584	9X98X582;L2:W2	183000_STR=05.86_EDG=AX6-1	2

Model	QUINTARA_DW107		
Creator	CHALEAMPON	.BCP Name	INDEX_C3D_KITCHEN2
Reviewer		Order	H001550
Approves		Date	27/02/2025

QUINTARA_DW107-1070X320X350

Colour

05.86=ML.EARTH TISSUE AX6 (TEXTILE)

Edge

01.408=1 AX6



K7L-160156480

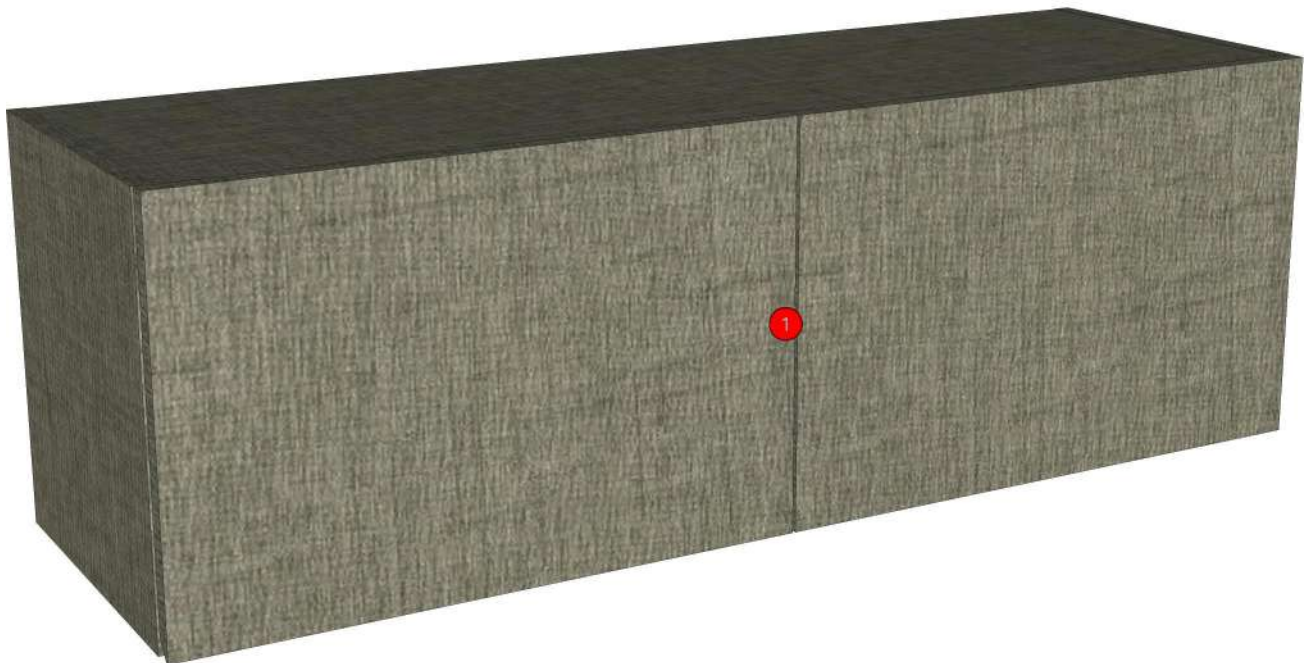

Model	-QUINTARA		
Creator	CHALEAMPHON	.BCP Name	INDEX_C3D_KITCHEN2
Reviewer		Order	H001550
Approves		Date	27/02/2025

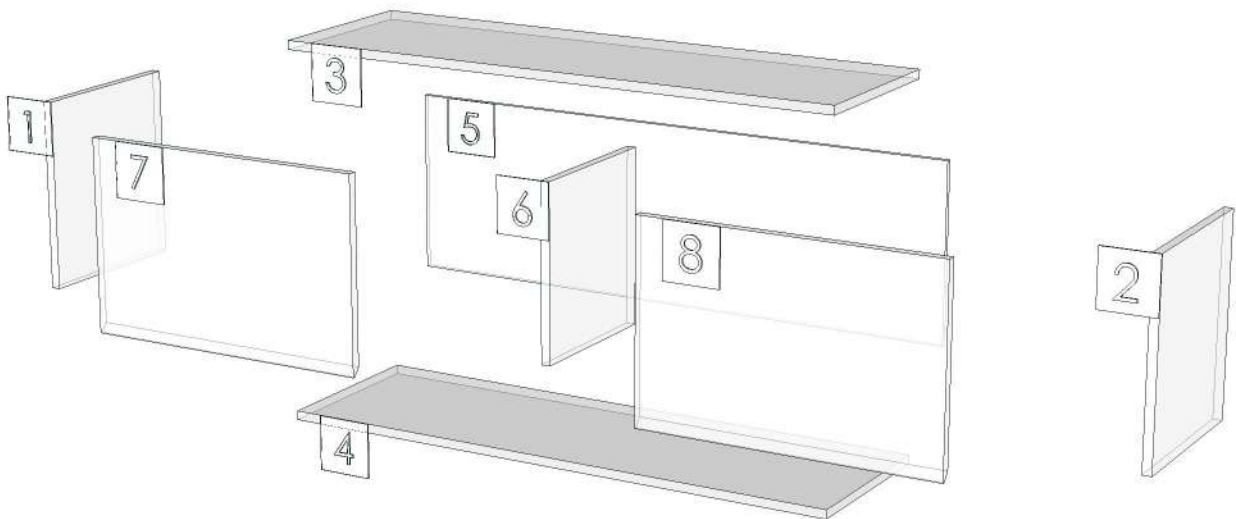

Model	QUINTARA_TOP_1810L		
Creator	CHALEAMPHON	.BCP Name	INDEX_C3D_KITCHEN2
Reviewer		Order	H001643
Approves		Date	09/04/2025

QUINTARA_TOP_1810L-1810X600X18

Colour

04.74=LAMINATE HPL CARBON TERRAZZO 8303SL PF (4X8 ??? 0.

NOTXTE3=NO TEXTURE HMR

30.32=LAMINATE HPL NO.#1097-UN (4'X8' ??? 0.8 MM.)

Edge

04.01=0.8 HPL



K7L-160156480

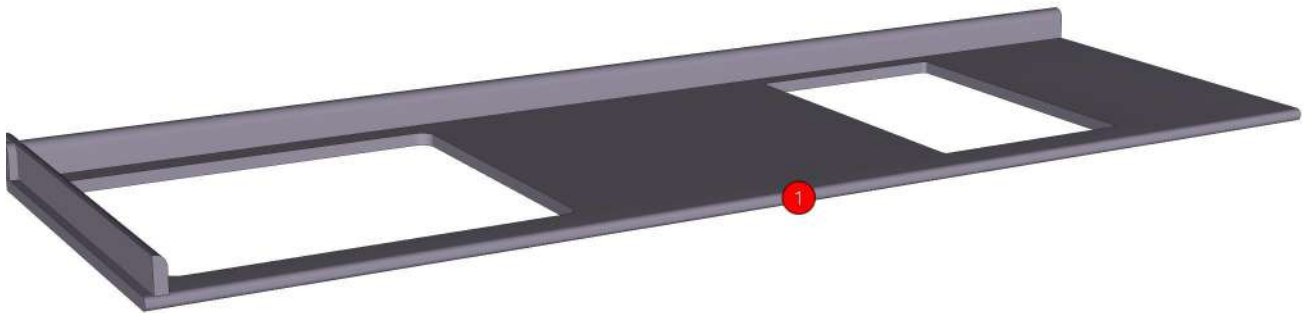

Model	QUINTARA_TOP_1810L		
Creator	CHALEAMPHON	.BCP Name	INDEX_C3D_KITCHEN2
Reviewer		Order	H001643
Approves		Date	09/04/2025

No.	Article No.	Description	Mat	Dimension	Cutting Size	Typepology	Skin
0	QUINTARA_TOP_1810L			1810x18x600			
	QUINTARA_TOP_1810L-01	TOP_POSTFROM	MDF-ST	18x600x1810	18X599.2X1809.2;L1:W1	182000_STR=NOTXTE3_EDG=HPL-.8	2
	QUINTARA_TOP_1810L-02	WATER LOTUS_POSTFROM TRUE	MDF-ST	18x50x1810	18X49.2X1809.2;L1:W1	183000_STR=30.32_EDG=HPL-.8	2
	QUINTARA_TOP_1810L-02A	WATER LOTUS_JUST IN CASE	MDF-ST	18x200x1810	18X200X1810;NO EDGE	183001_STR=30.32_EDG=-	2
	QUINTARA_TOP_1810L-03	WATER LOTUS_POSTFROM TRUE	MDF-ST	18x50x650	18X49.2X648.4;L1:W2	184000_STR=30.32_EDG=HPL-.8	2
	QUINTARA_TOP_1810L-03A	WATER LOTUS_JUST IN CASE	MDF-ST	18x200x650	18X200X650;NO EDGE	184001_STR=30.32_EDG=-	2