

FUKUOKA-P

BED 5 ft.
BED 6 ft.

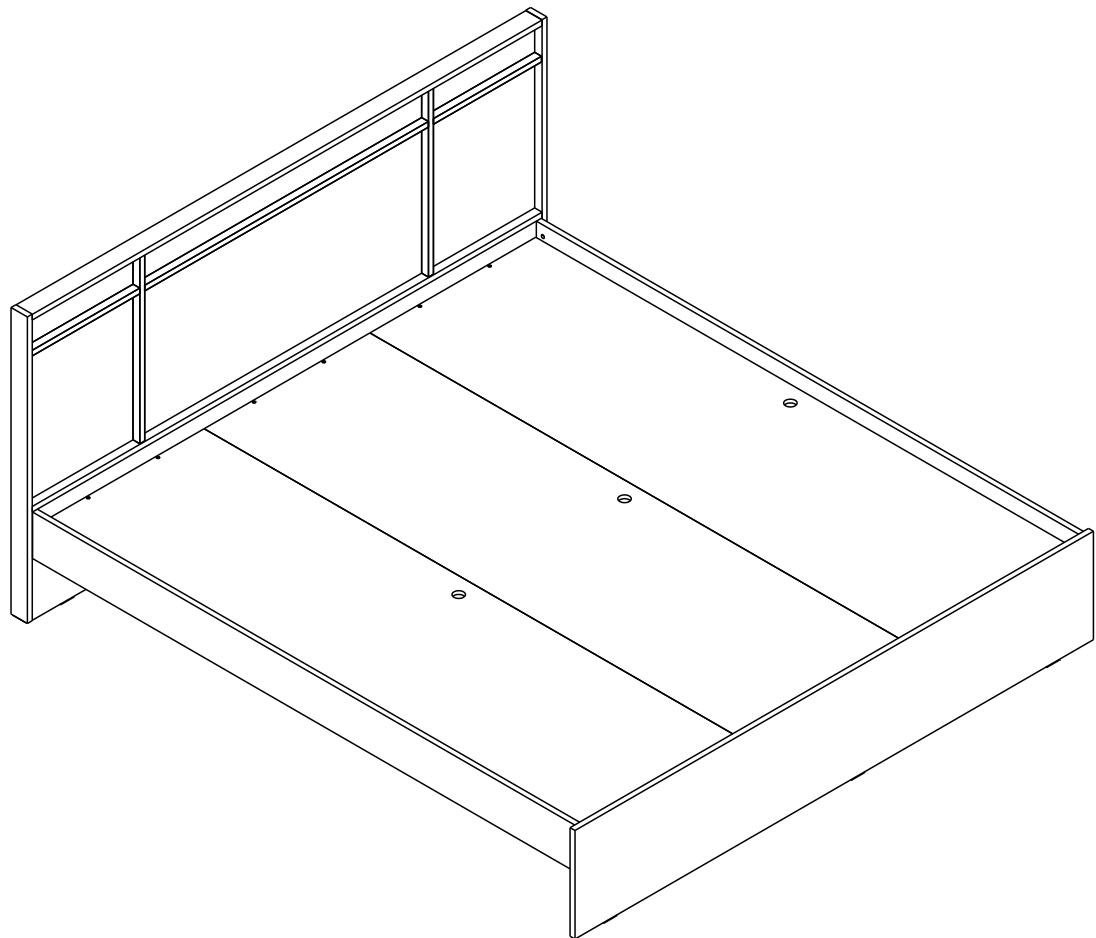

CONNECT SYSTEM

1

3

2

(Connecting bolts)

WHEN FITTING CAMS
 ENSURE STARTING POSITION IS CORRECT
 BEFORE YOU INSERT CONNECTING BOLT
 TURN CLOCKWISE UNTIL SECURE

✓				✗
↑	CORRECT	WRONG		

M4x16mm.

i

40mm.

EQ

M6x45mm.

M6

M6

M4x16mm.

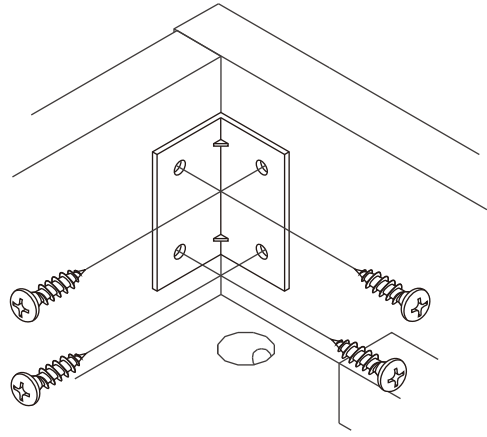
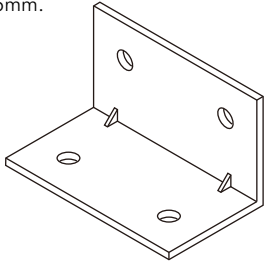

HARDWARE

-BODY SET

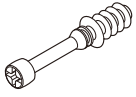

x 4



19mm.

x 4

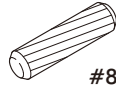

#8x35

x 4



M4x16mm.

x 27

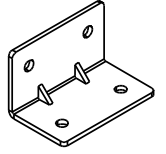

x 4

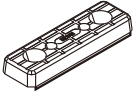

x 3



#M6

x 4



#M6

x 4

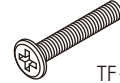

TF+M6x45

x 4



M4x16mm.

x 6

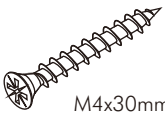

M4x30mm.

x 48

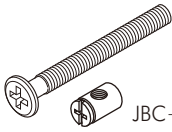

JBC+M6x60

x 4



No.1

x 3

ASSEMBLY

-BODY SET

1.

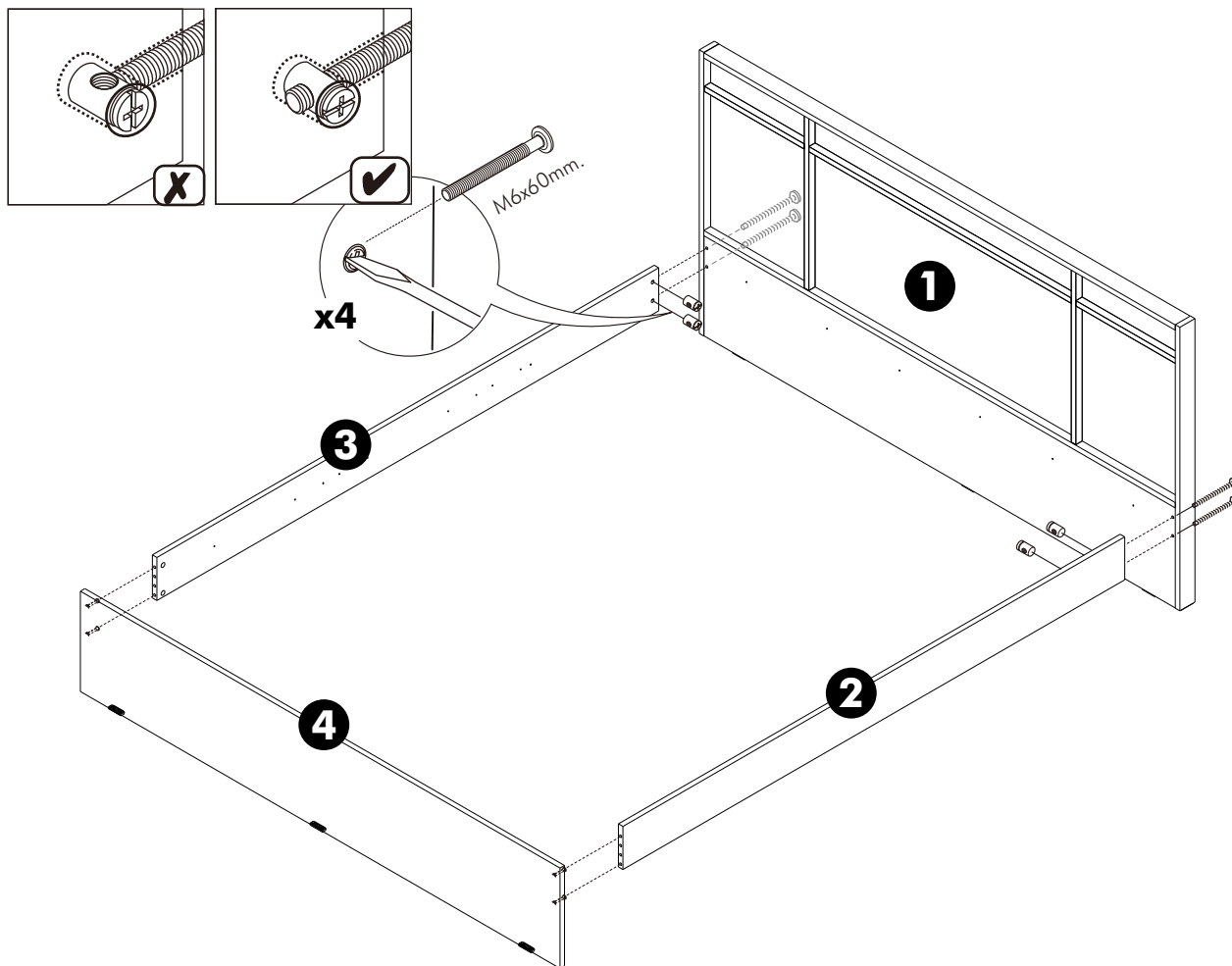

2.

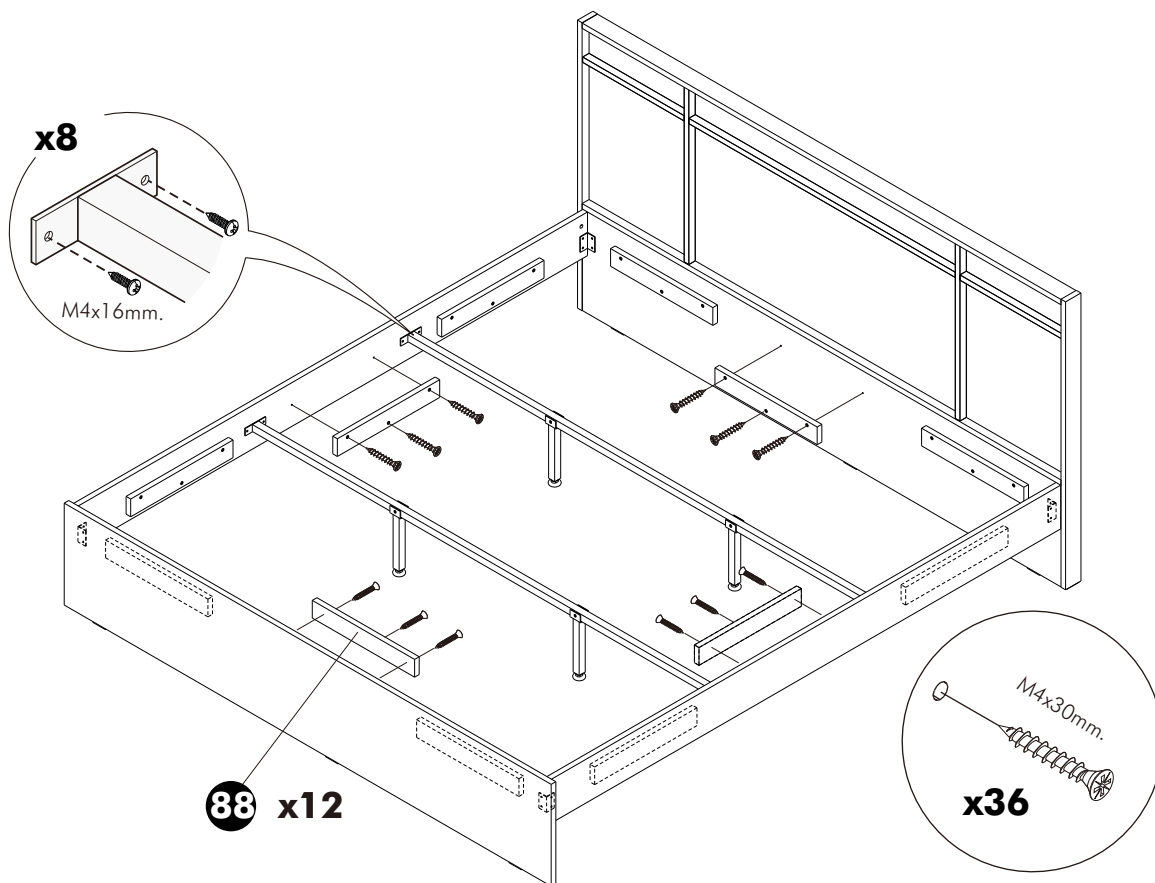

3.

