

VELO

BED 6 ft.

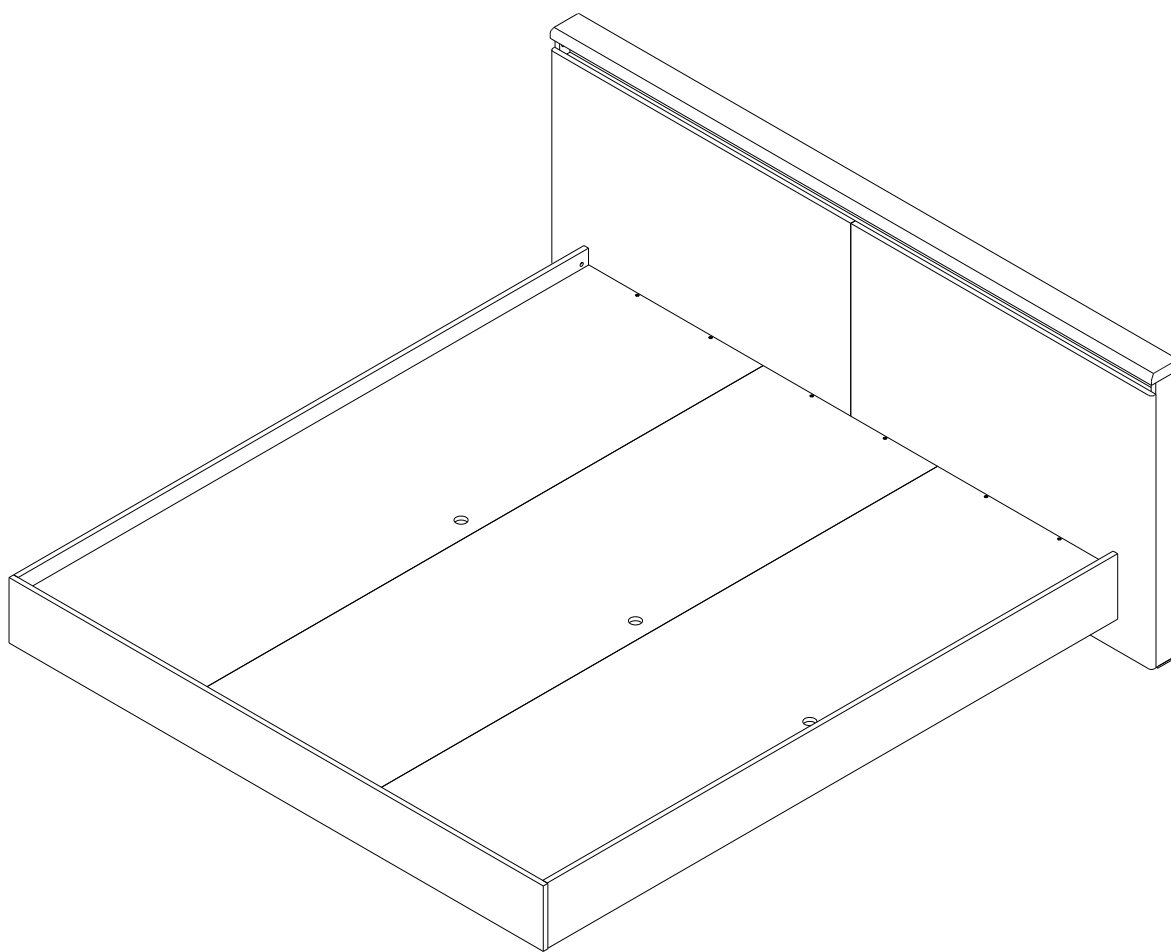

CONNECT SYSTEM

1

3

2

(Connecting bolts)

WHEN FITTING CAMS
 ENSURE STARTING POSITION IS CORRECT
 BEFORE YOU INSERT CONNECTING BOLT
 TURN CLOCKWISE UNTIL SECURE

✓				✗
↑				
CORRECT		WRONG		

M4x16mm.

i

40mm.

EQ

M6x45mm.

M6

M6

M4x16mm.

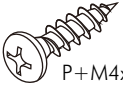
 P+M4x16mm.

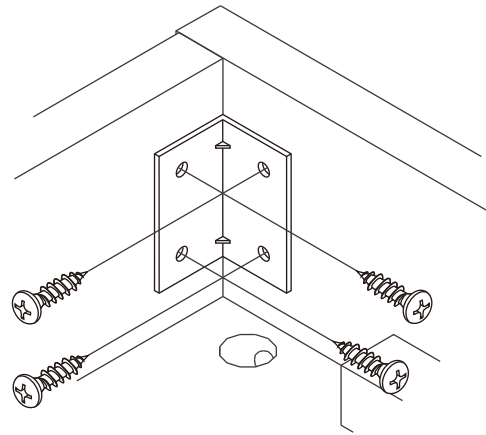
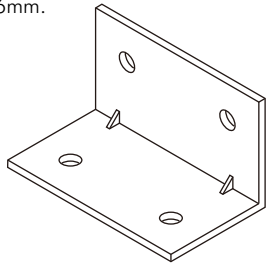

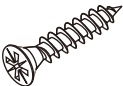
 M4x16mm.

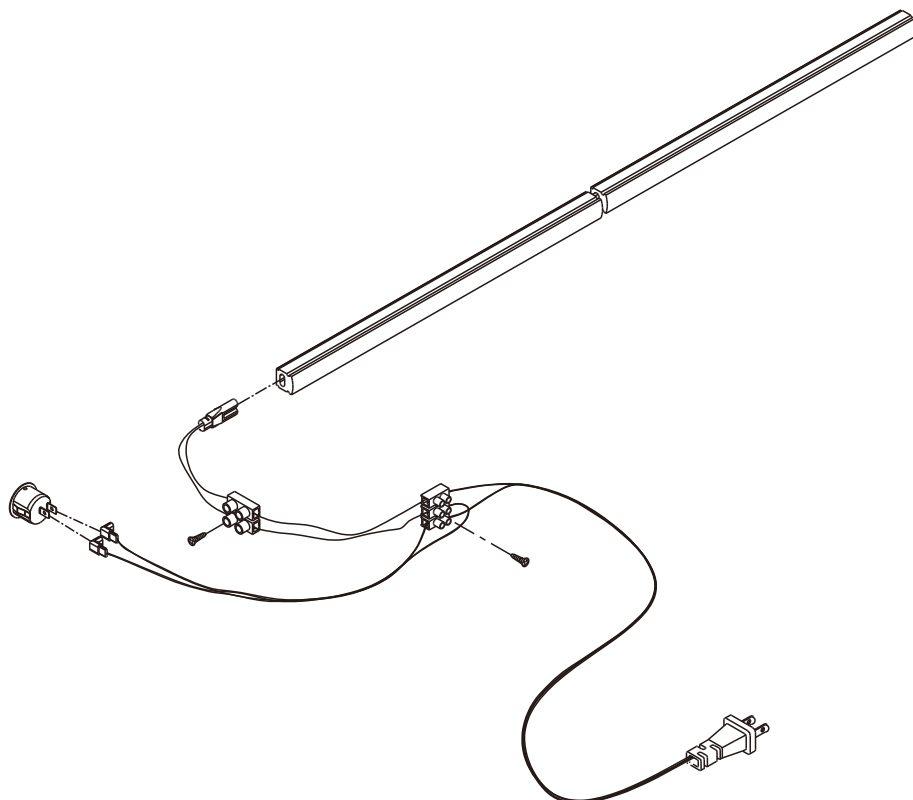
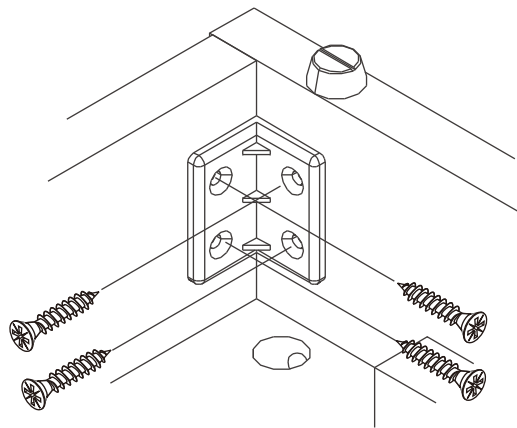
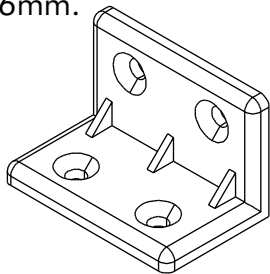

HARDWARE

-BODY SET

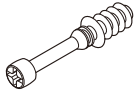

x 4



x 4

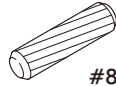

#8x35
x 8



M4x16mm.
x 35

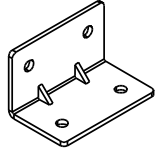

x 4

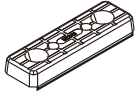

x 4



#M6
x 4



#M6
x 4

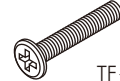

TF+M6x45
x 4



M4x16mm.
x 32



M4x30mm.
x 56

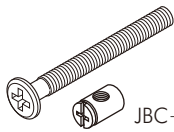

JBC+M6x60
x 6



No.1
x 3

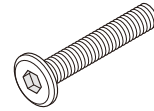

#TFL4 M8x50
x 4



#M8
x 4



#M8
x 4



M4x13mm.
x 6



x 2

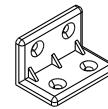

x 6

-LAMP SET

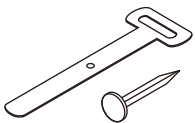

x 15/15



5x3/4"mm.
x 2



x 1



x 1

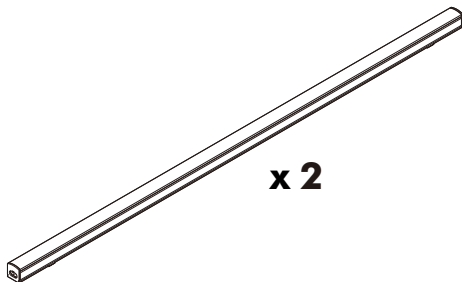

x 2

ASSEMBLY

-BODY SET

1.

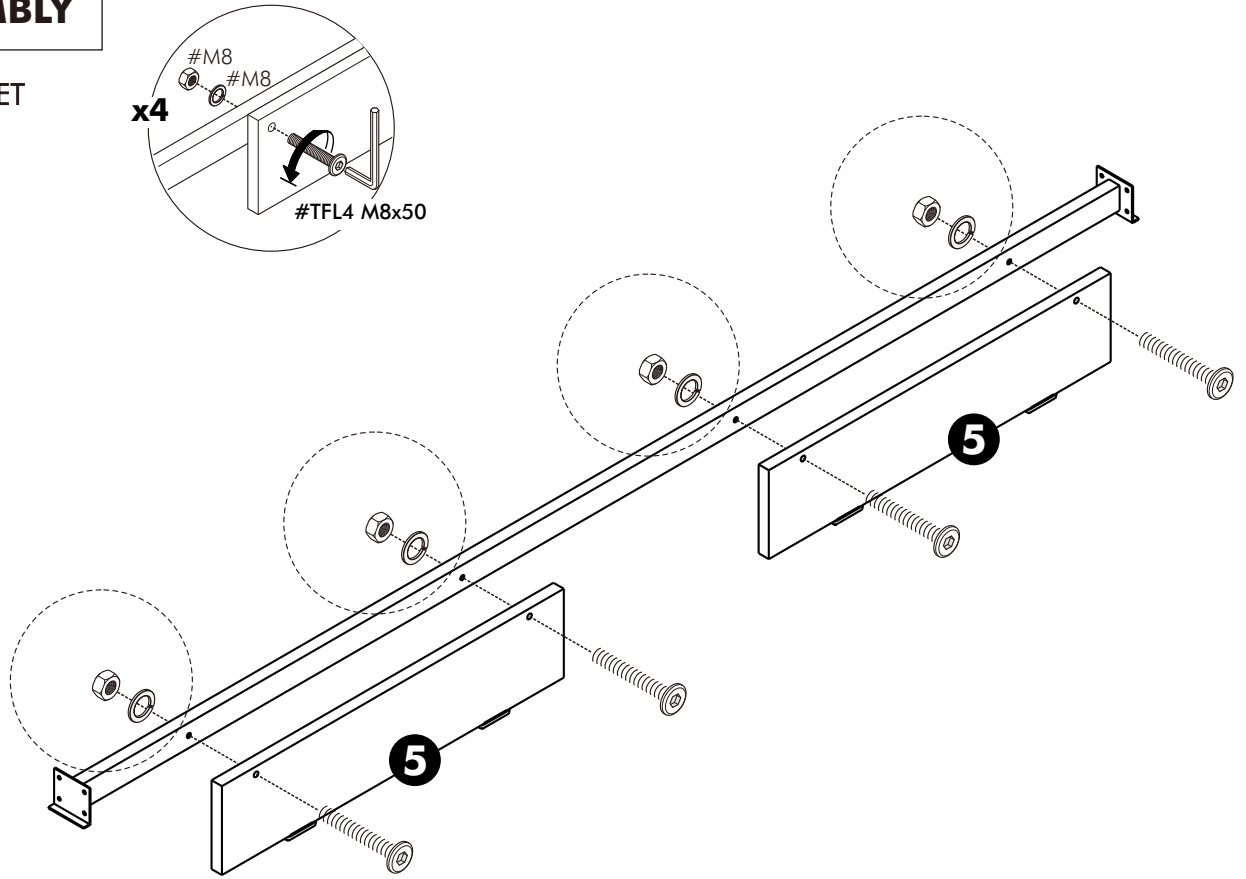

2.

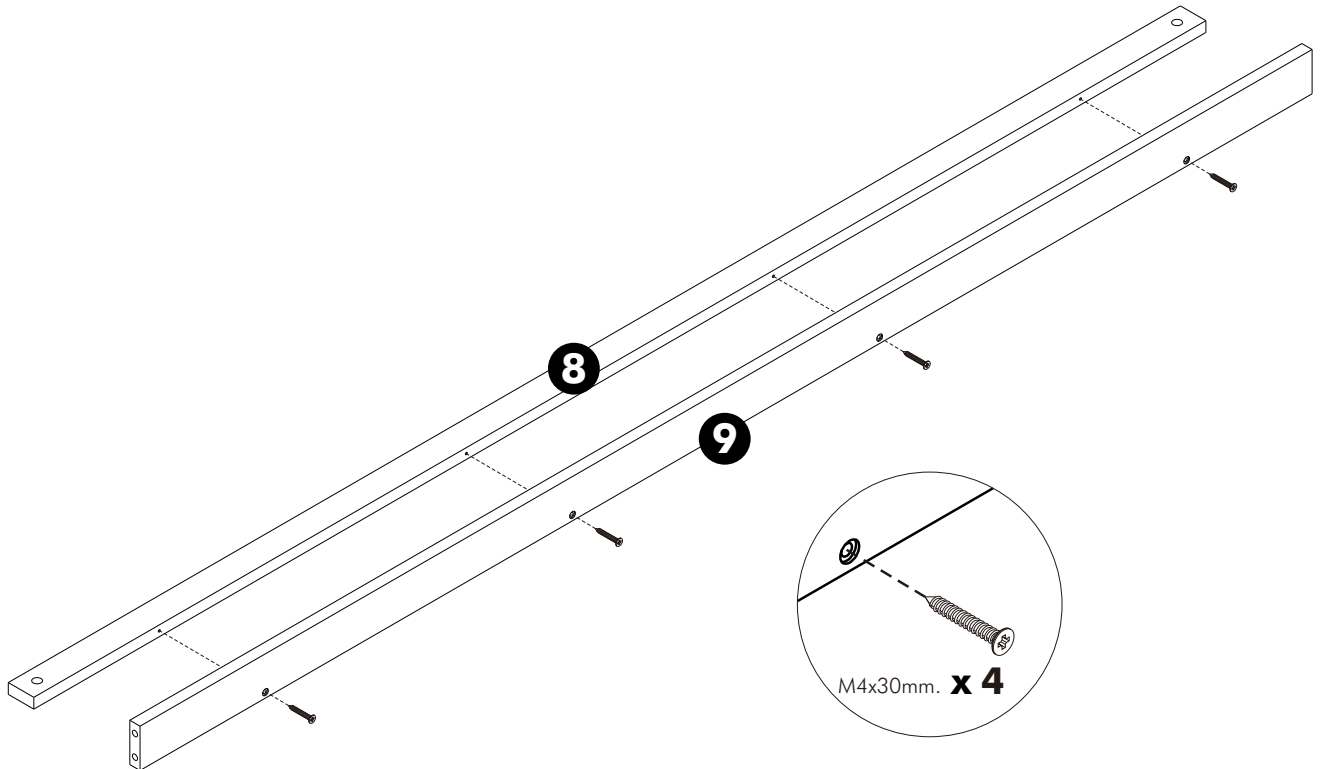

3.

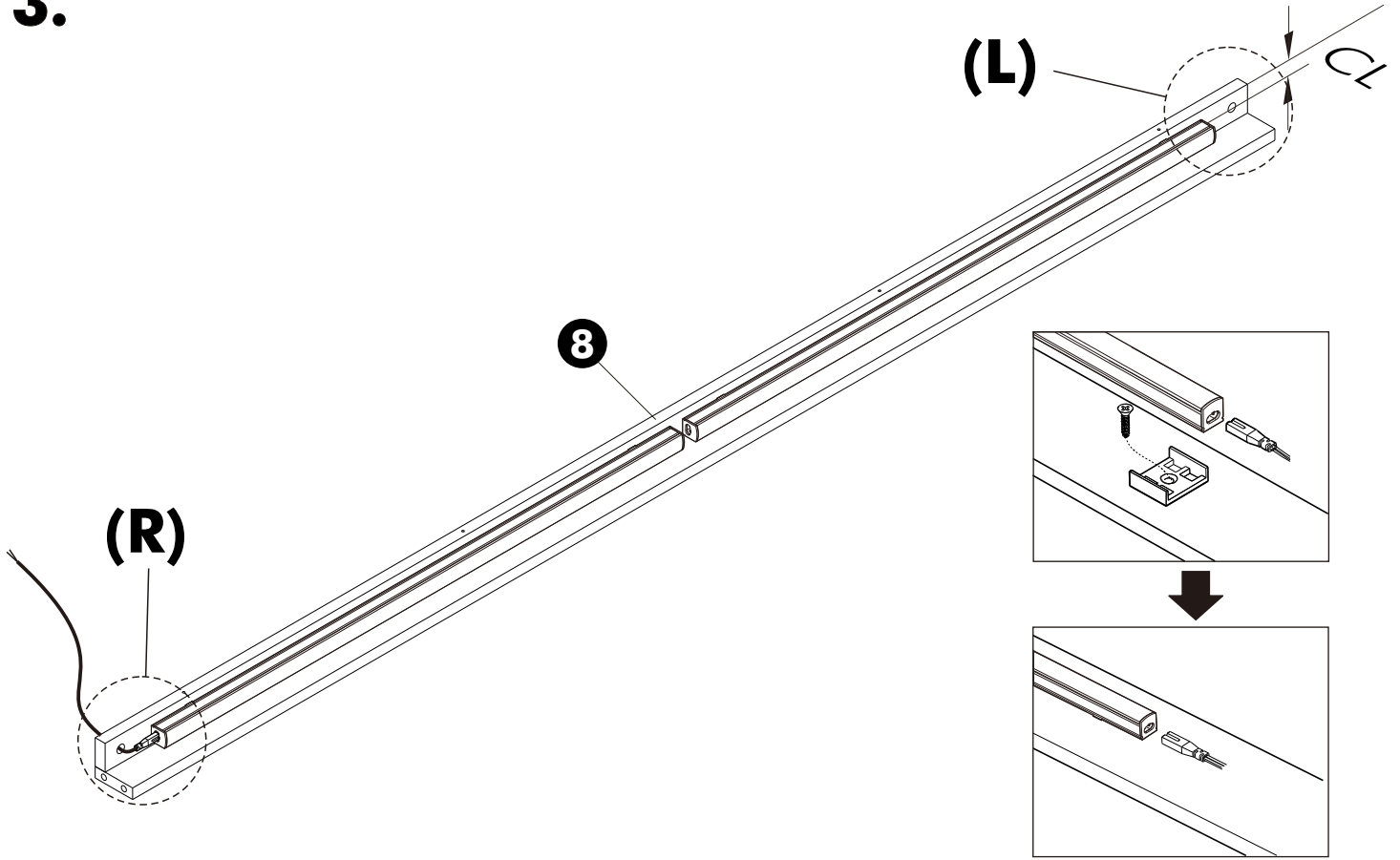

4.

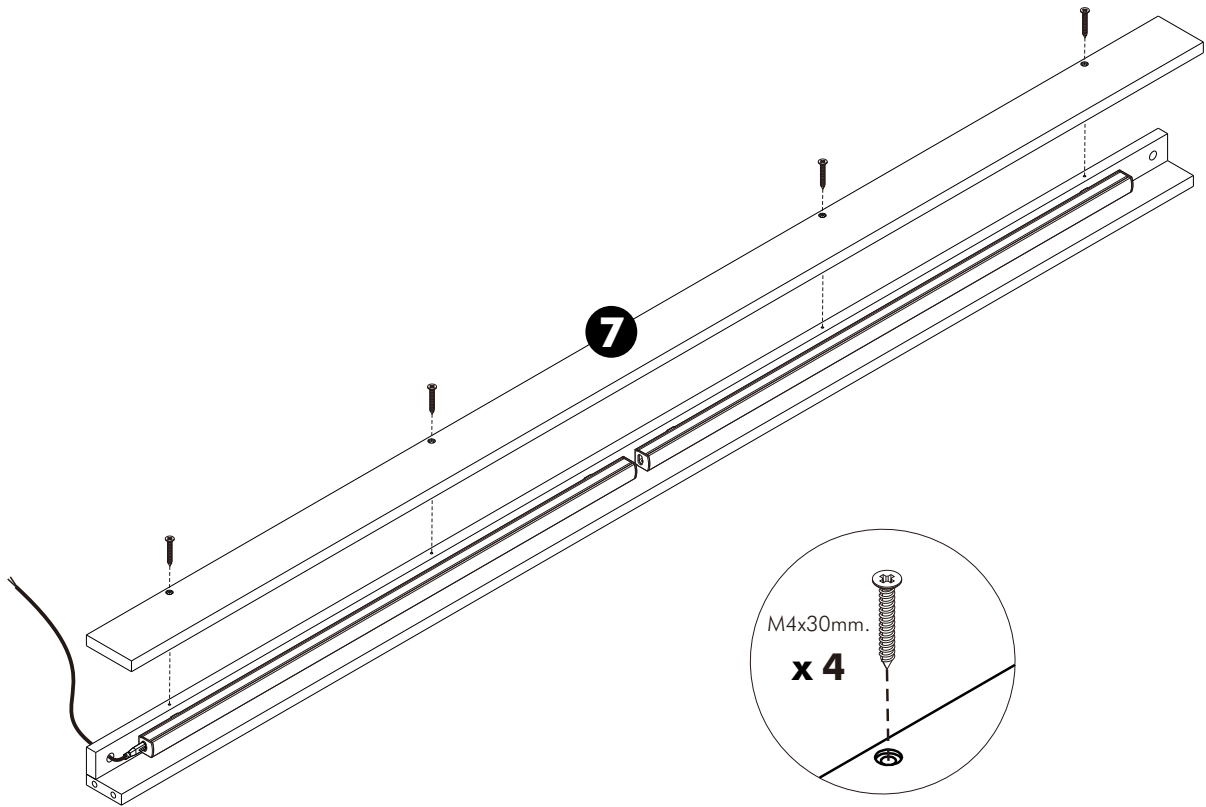

5.

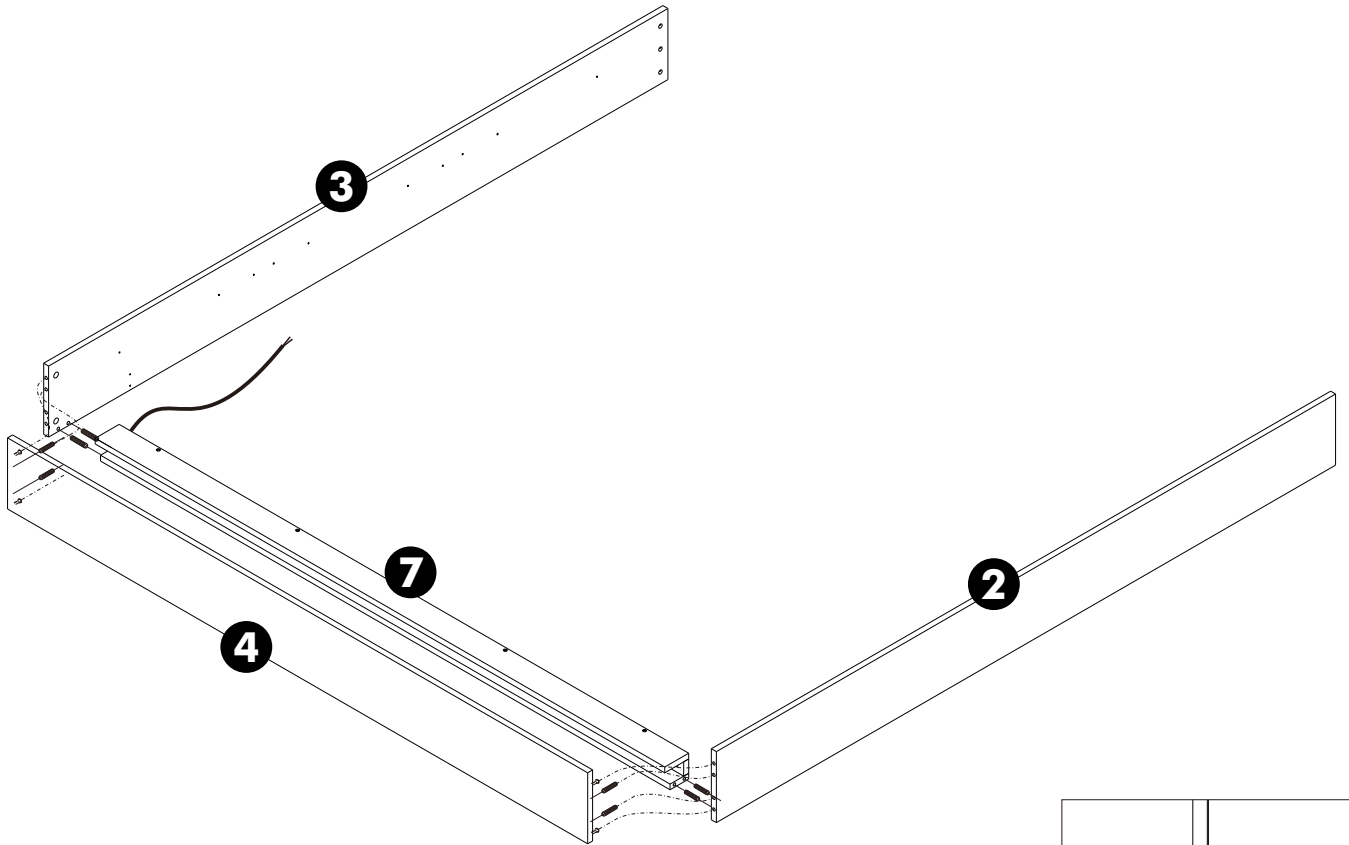

6.

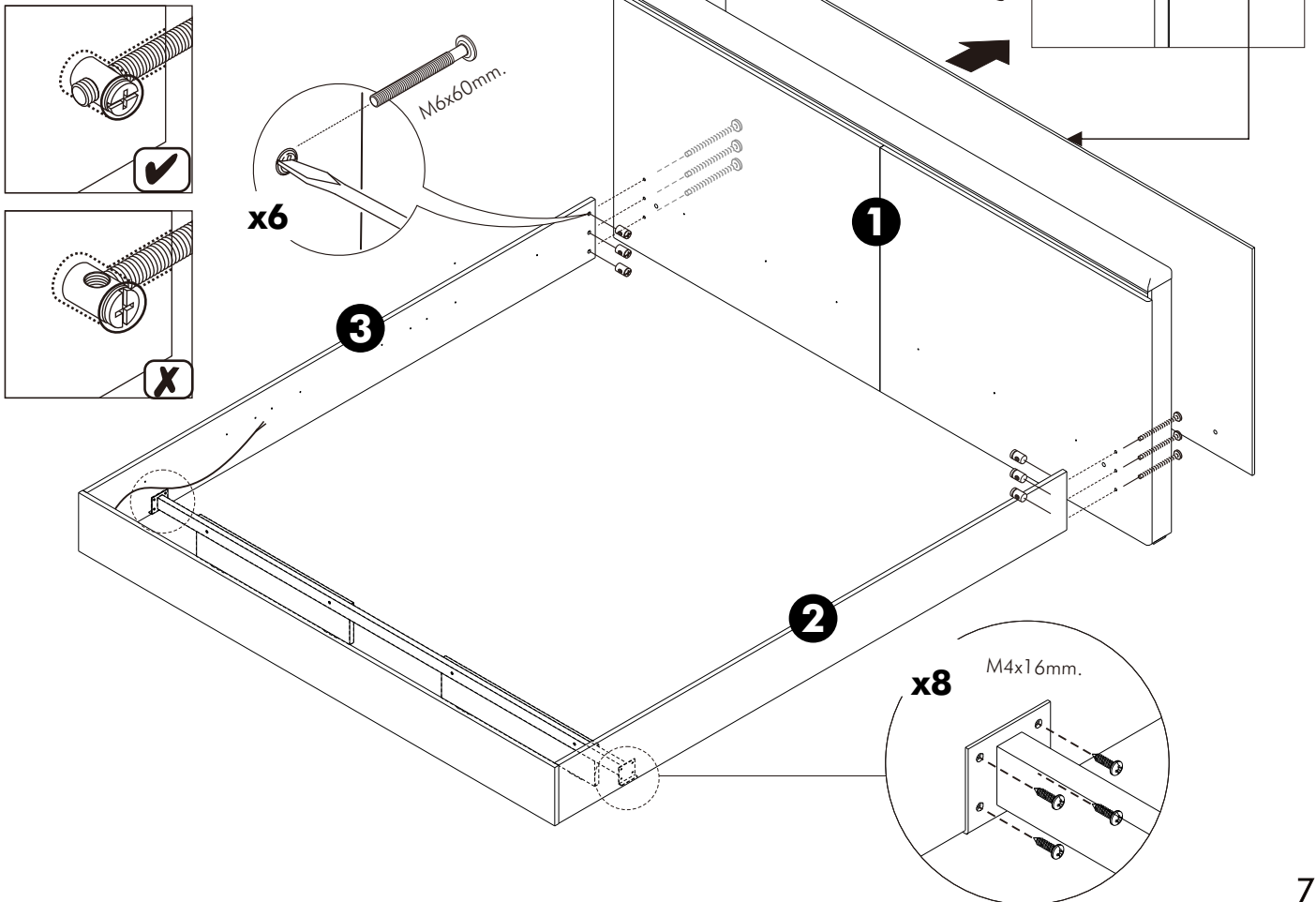

7.

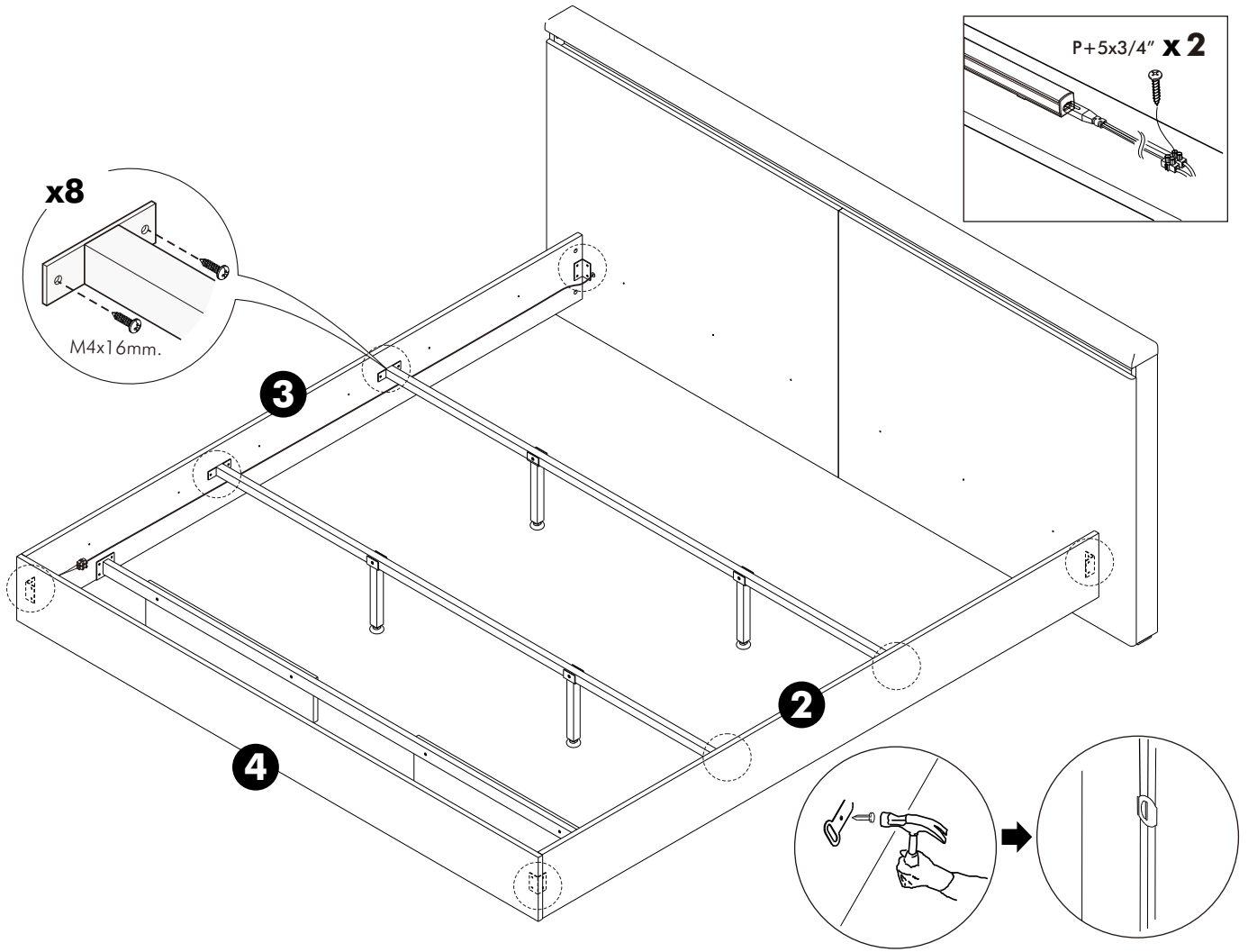

8.

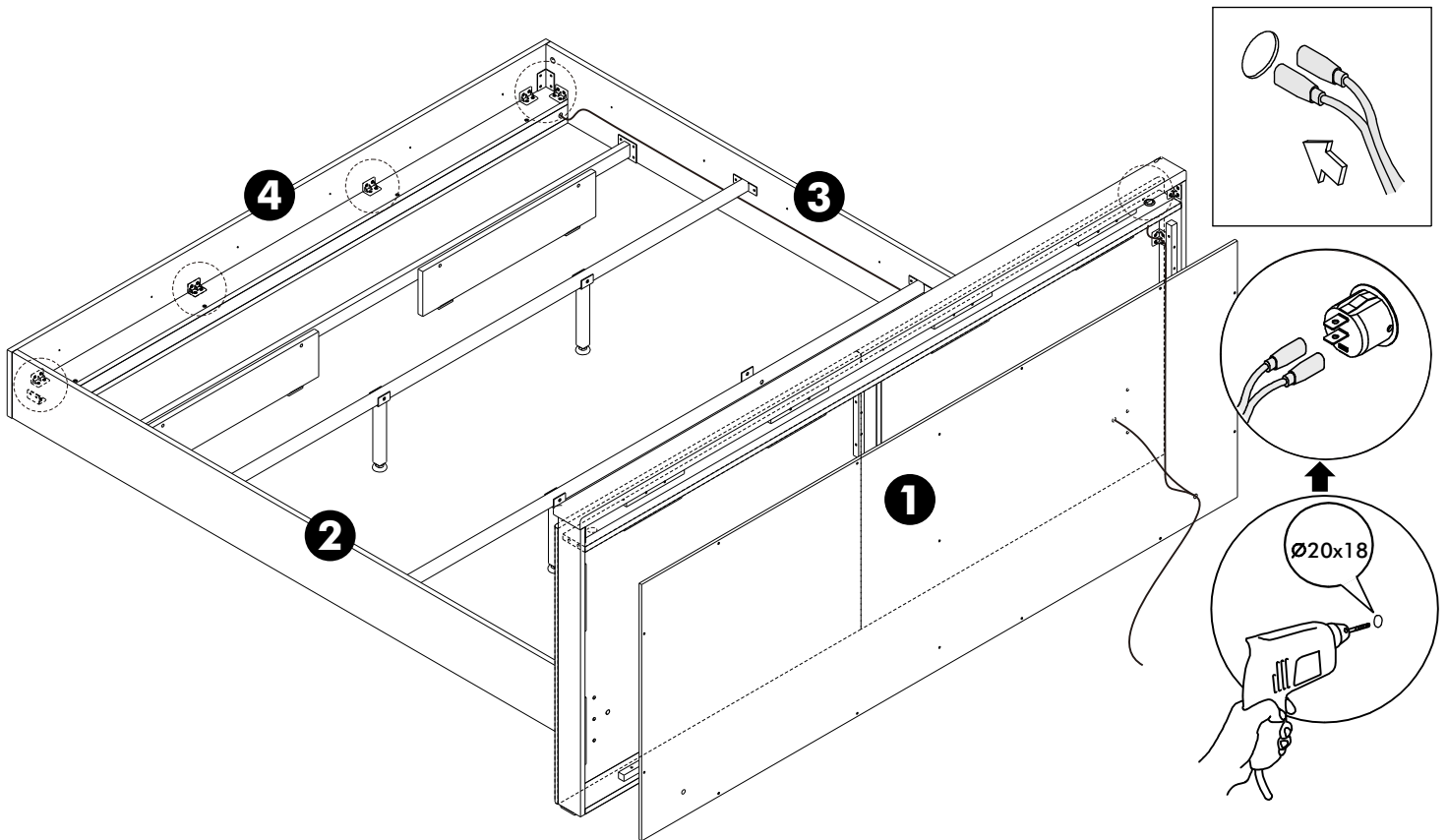

9.

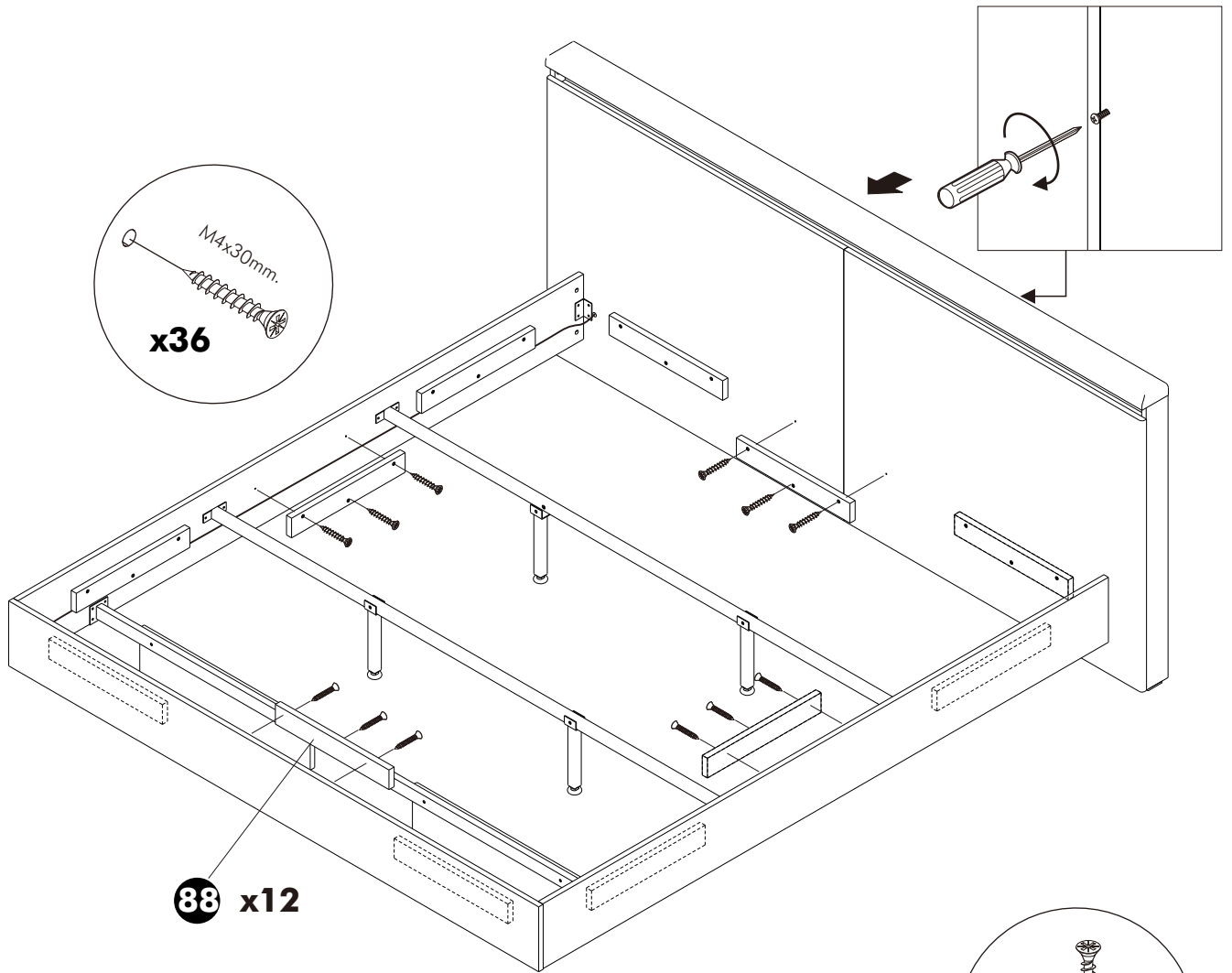

10.

