

NOIR/P

Tv Cabinet 180 Cm.

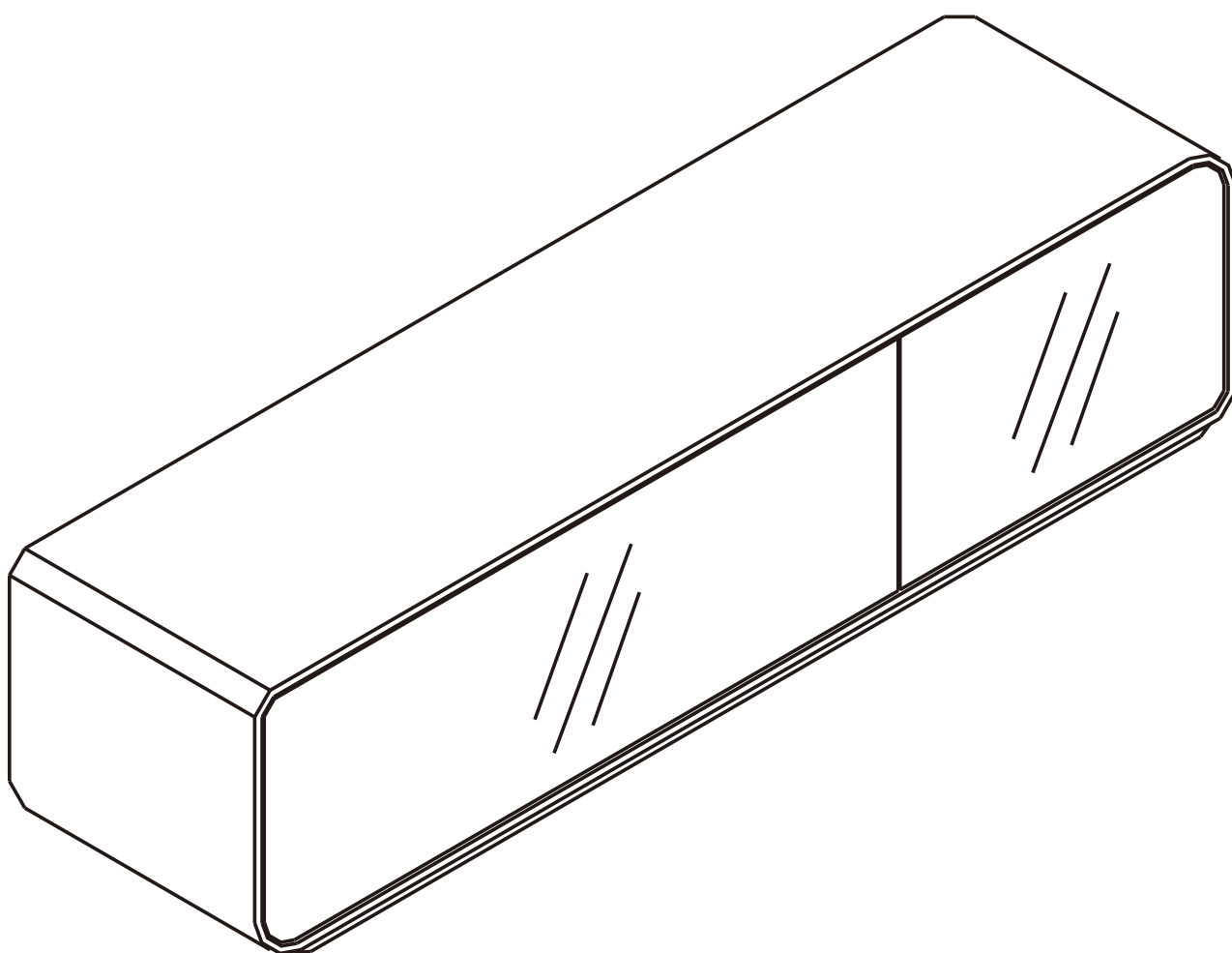

CONNECT SYSTEM

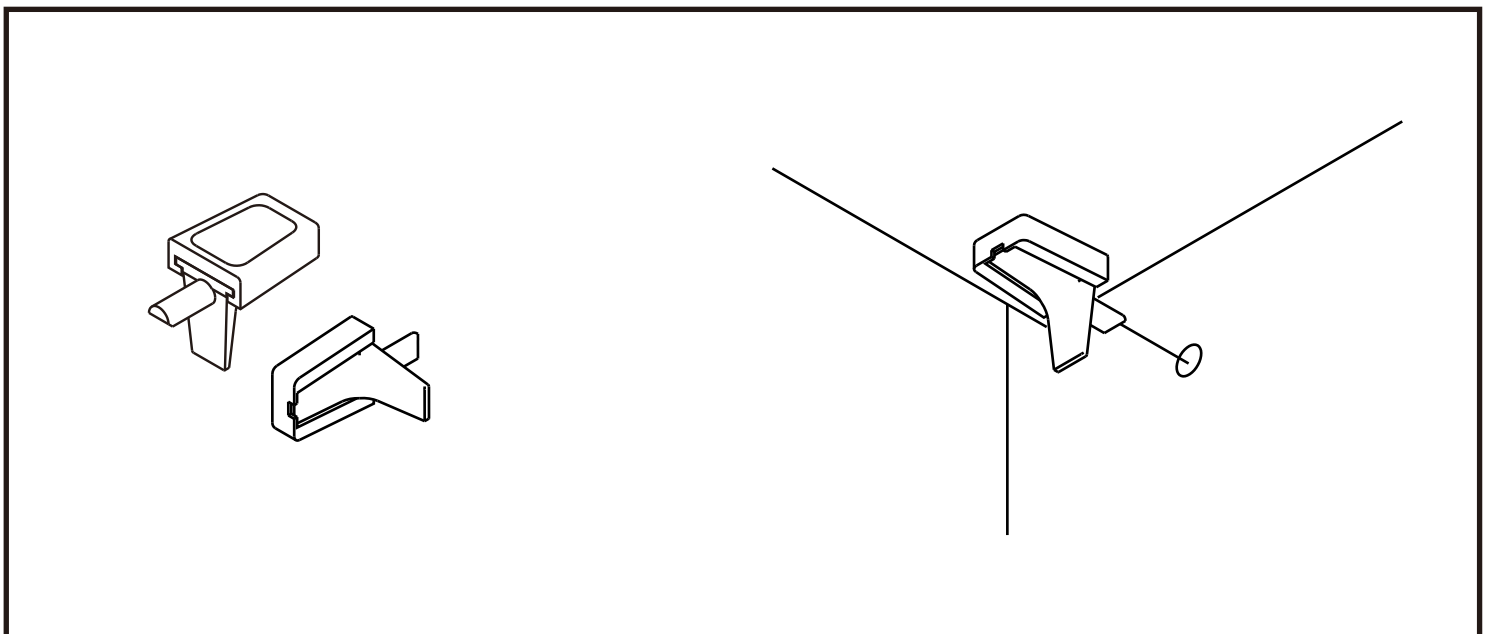
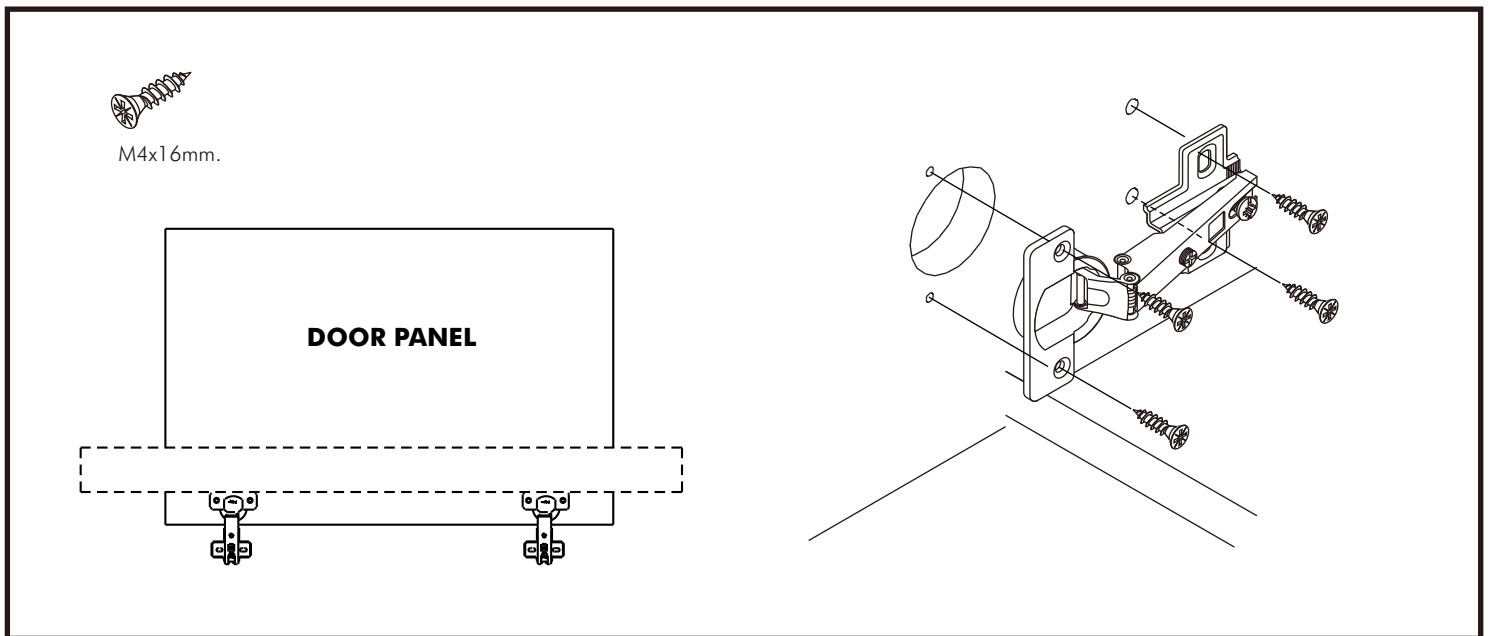
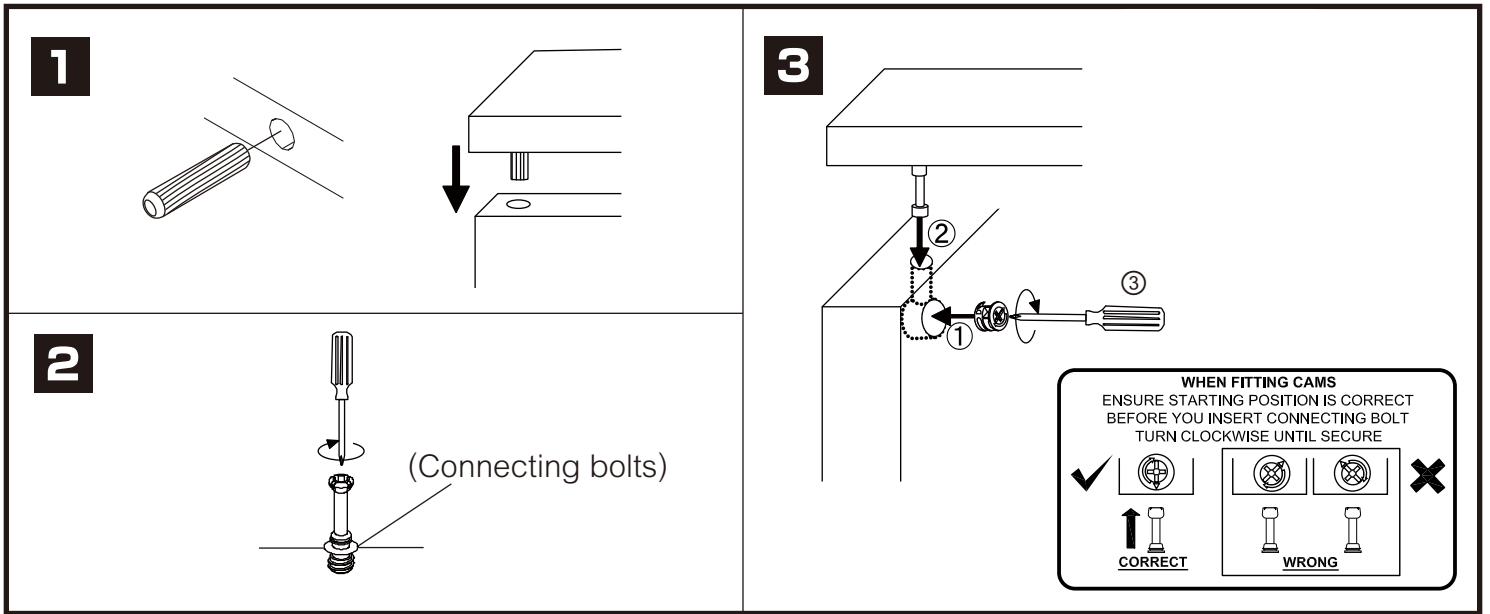

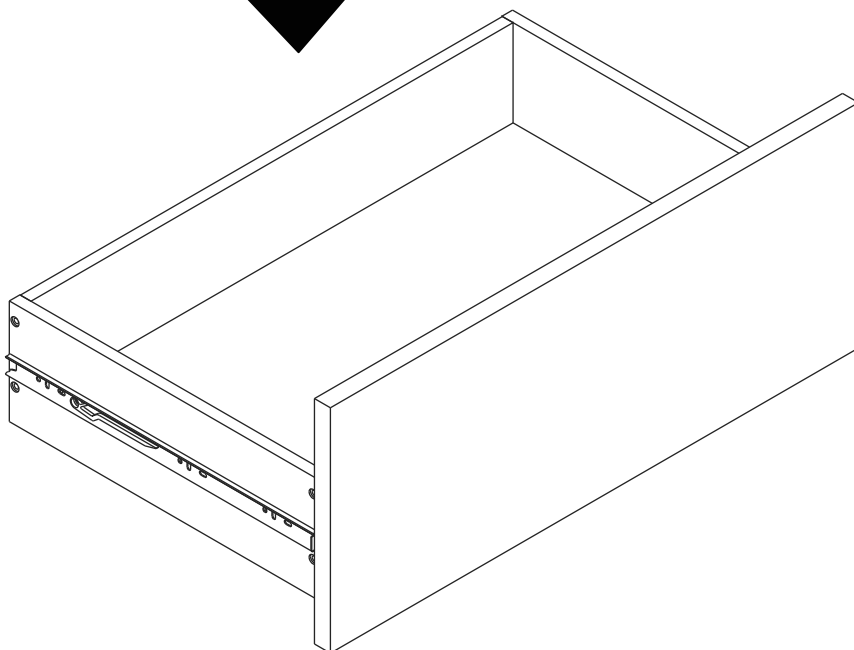
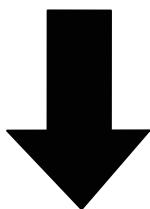
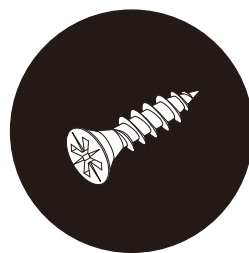
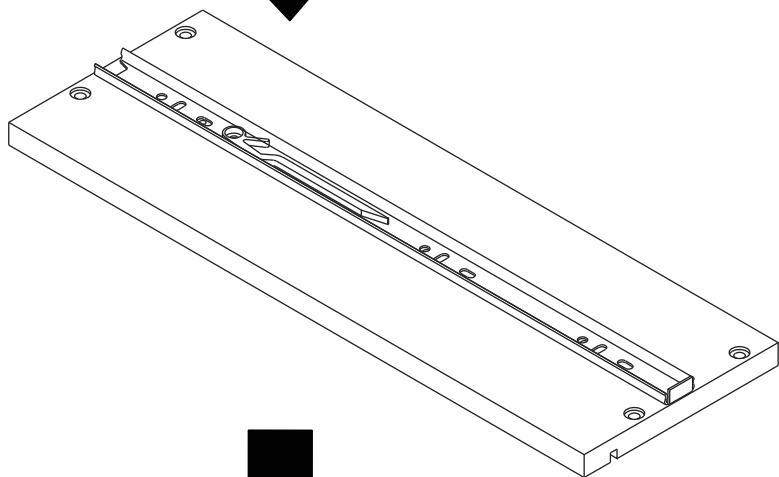
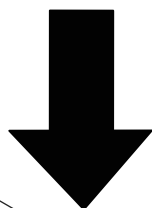
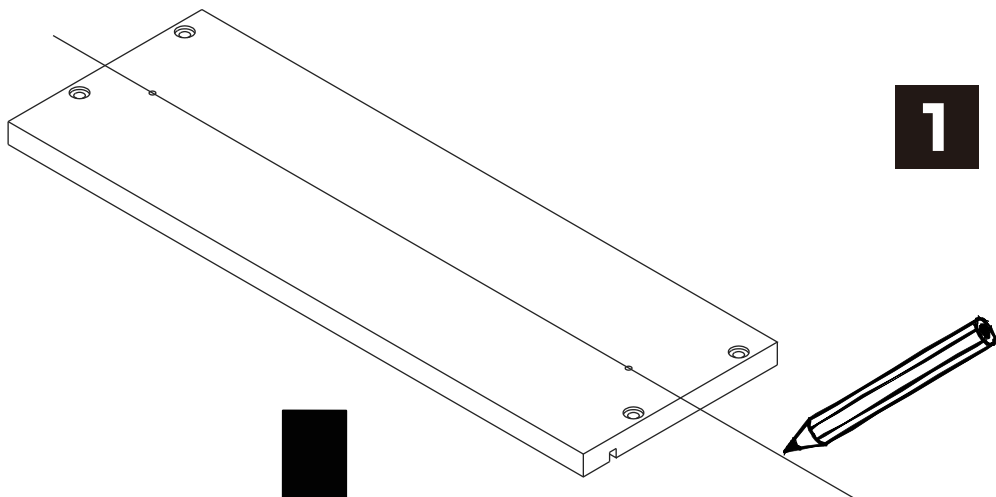

HARDWARE

-BODY SET

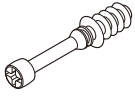

x 14



x 14

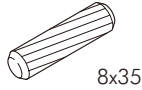

8x35

x 16



x 12

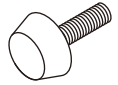

x 8

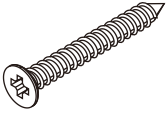

M4x40mm.

x 4

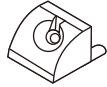

x 8



x 2



x 4

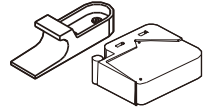

x 3



M4x20mm.

x 8



M4x25mm.

x 10

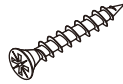

M4x35mm.

x 16



M3.5x16mm.

x 2



#5x1/2"

x 6



#5x3/4"

x 6

-DRAWER SET

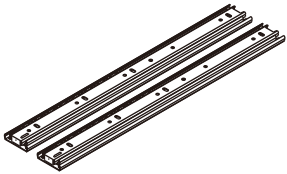

x 2



M5x10.5mm.

x 9



M3.5x13mm.

x 15

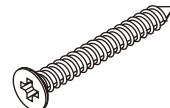

M4x40mm.

x 20



TFL4 M6x23

x 10

-DOOR SET

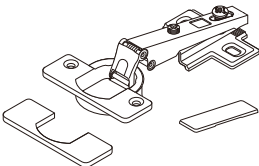

x 2



M4x16mm.

x 4





M4x25mm.

x 4

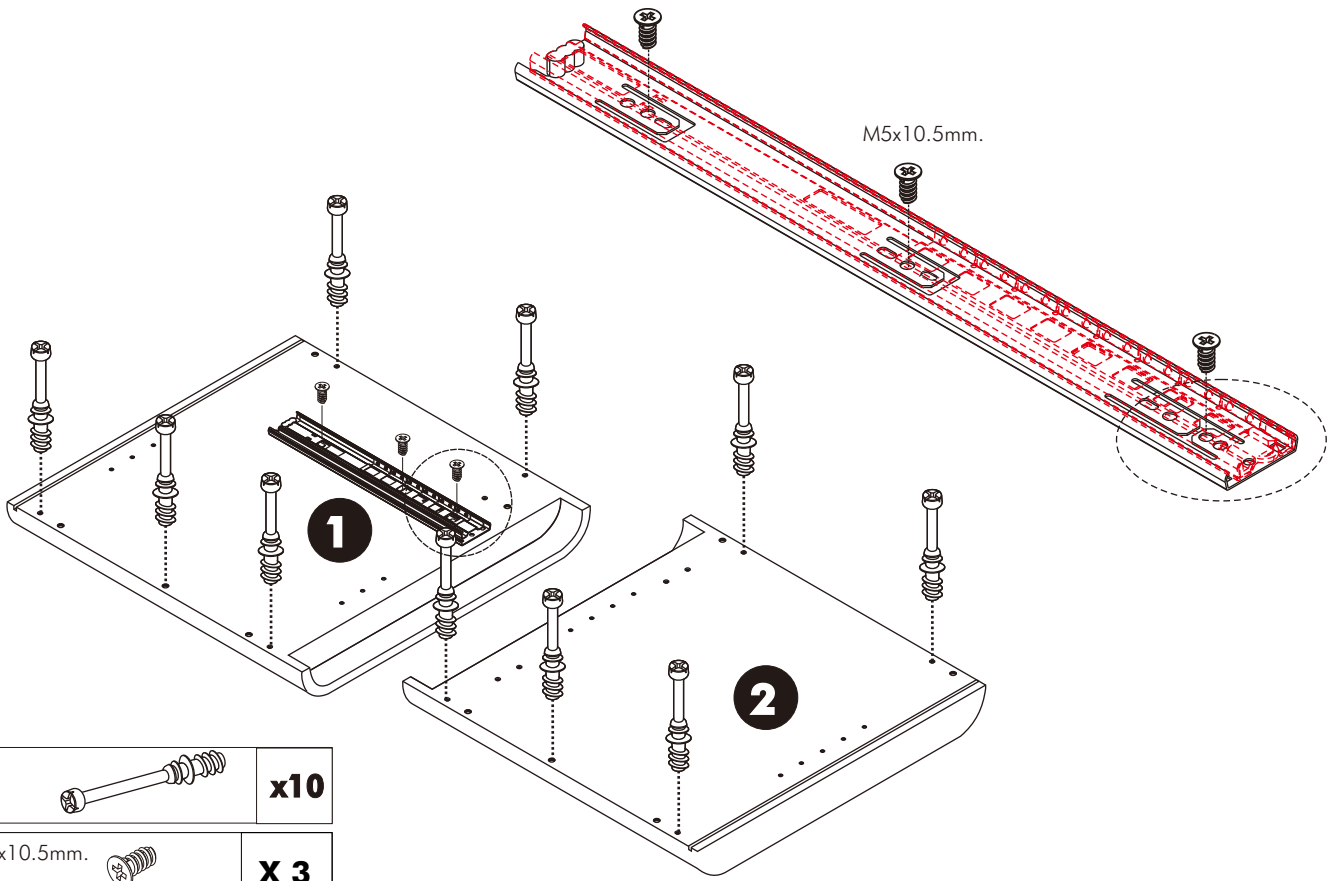
1.



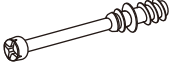

M5x10.5mm.

	x10
M5x10.5mm. 	x 3
	x 1

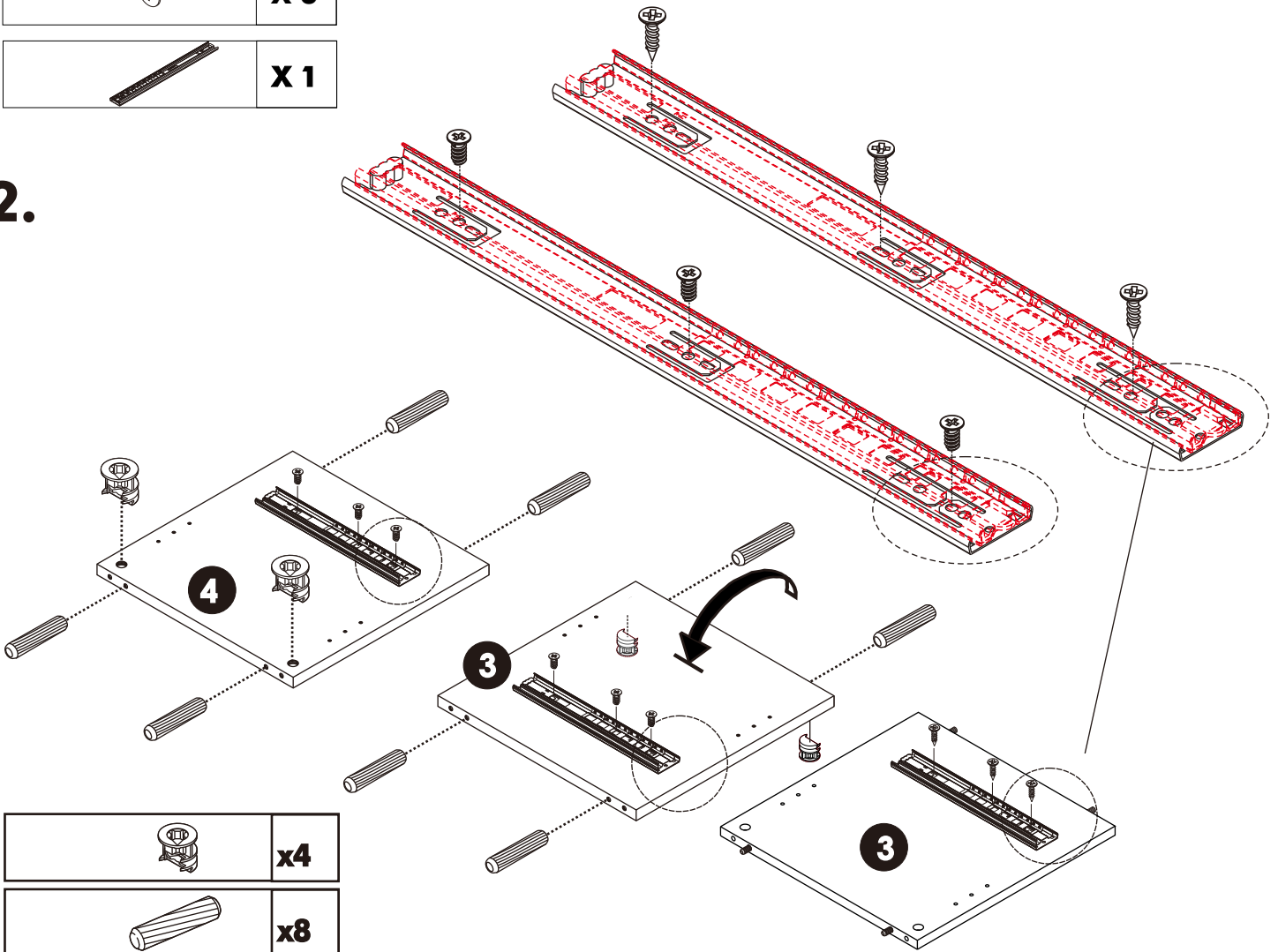
2.



	x4
	x8
M5x10.5mm. 	x 6

	x 3	M3.5x13mm. 	x 3
---	------------	--	------------

3.

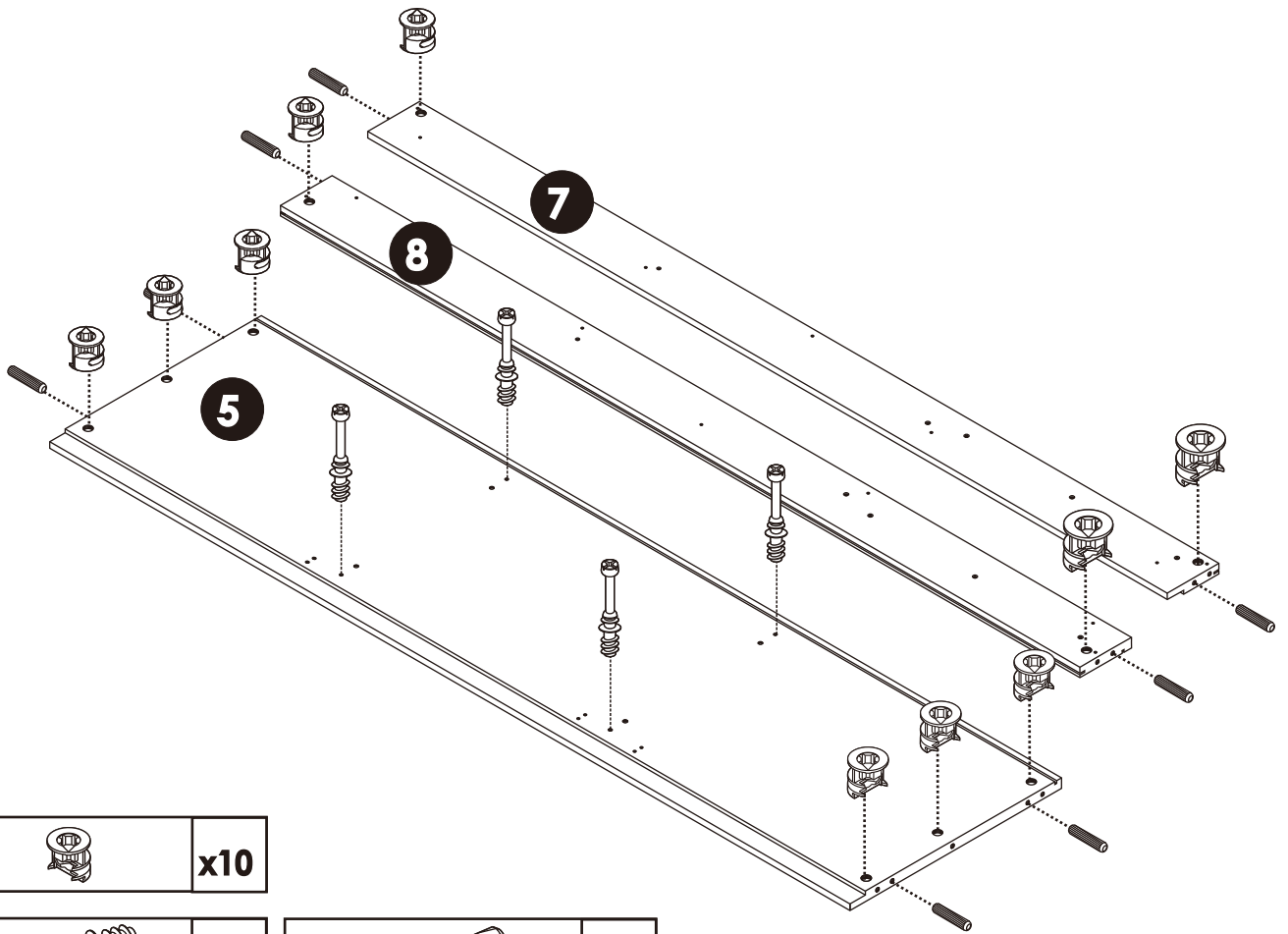

	x10
---	------------

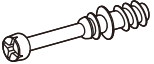
	x4
---	-----------

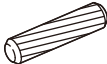
	x8
---	-----------

4.

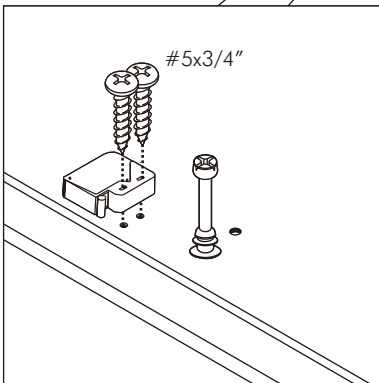
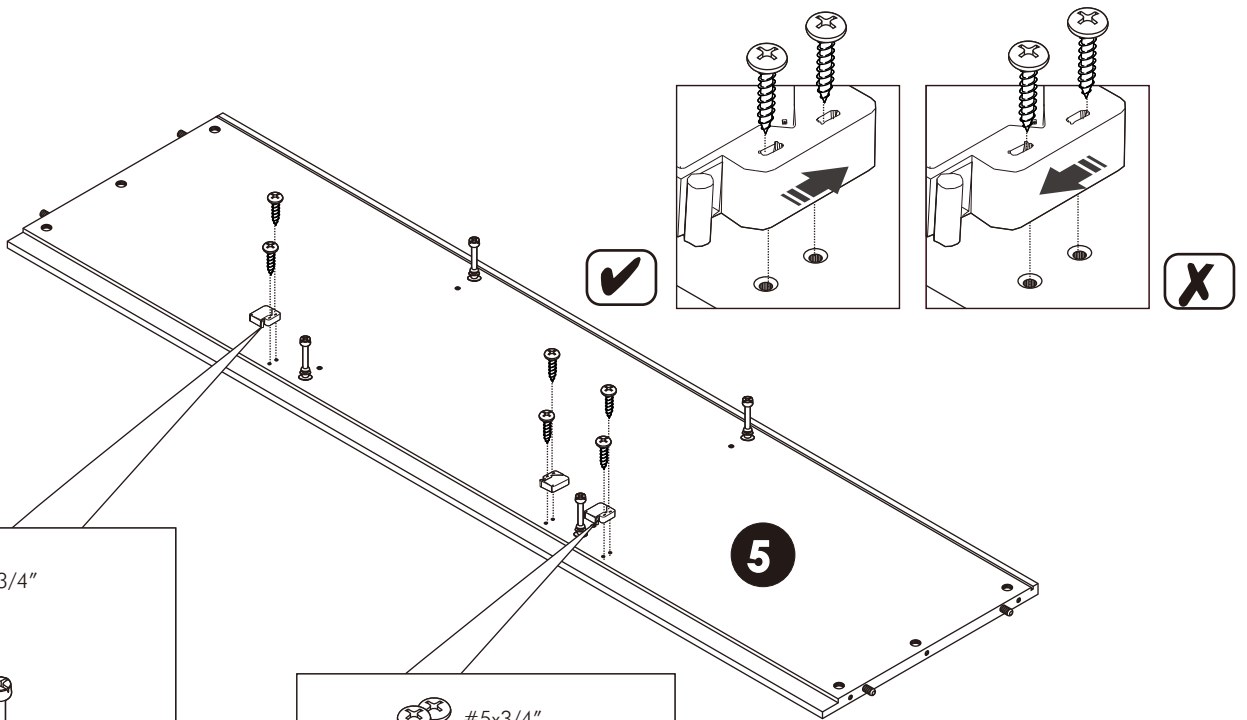

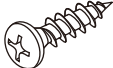
	x6
---	-----------

	x3
---	-----------

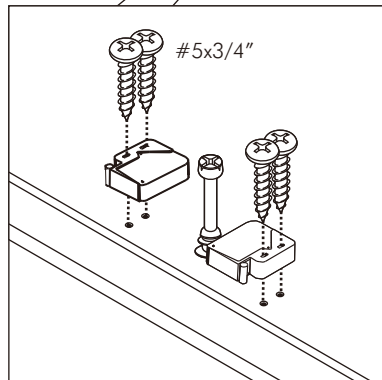

5.

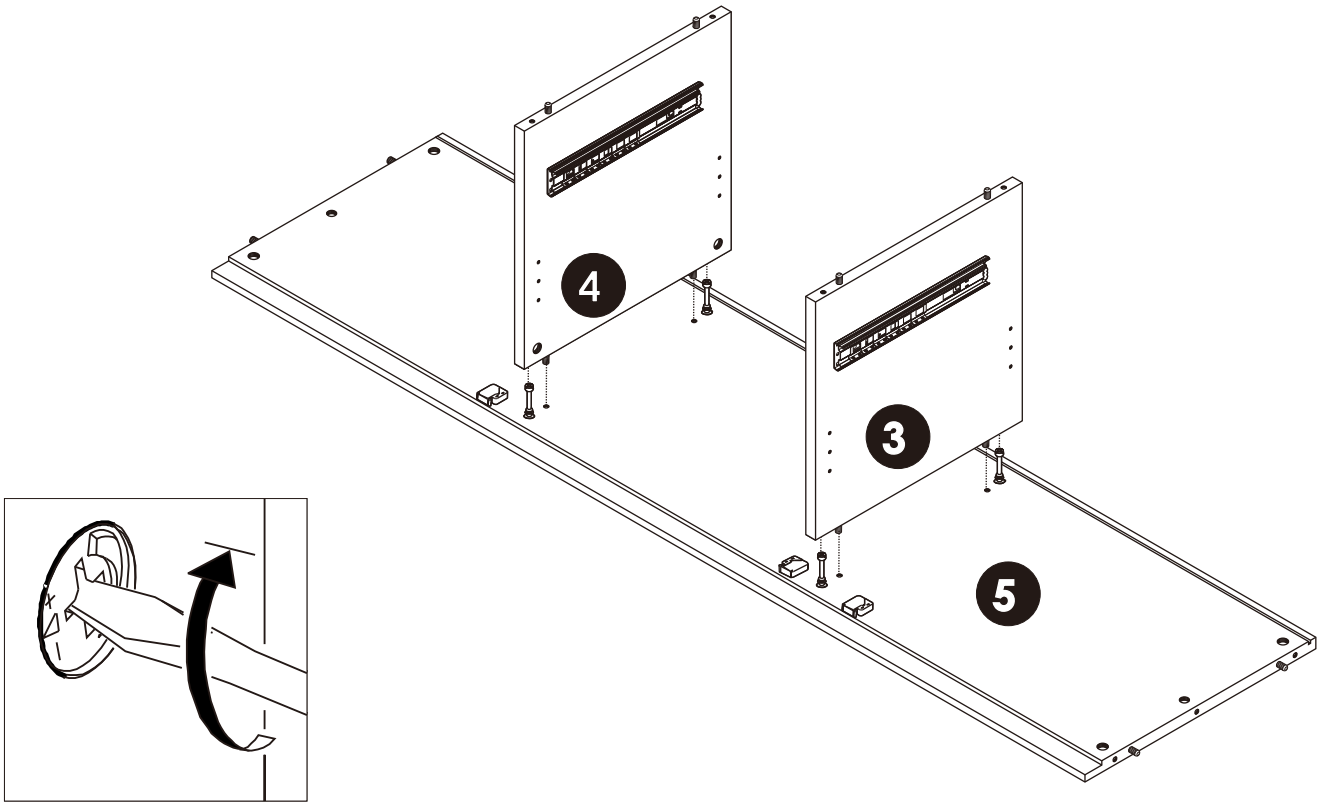

6.

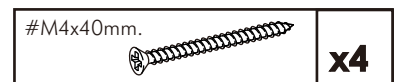
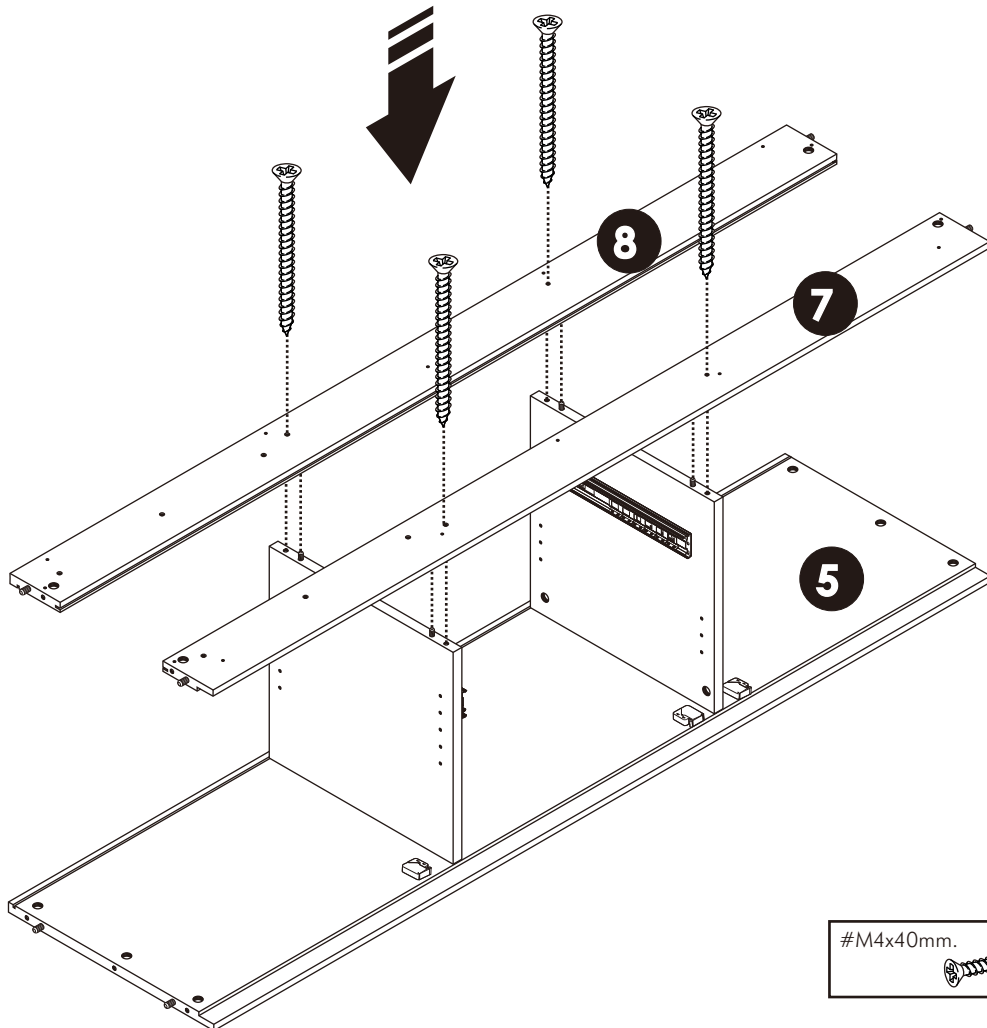

7.

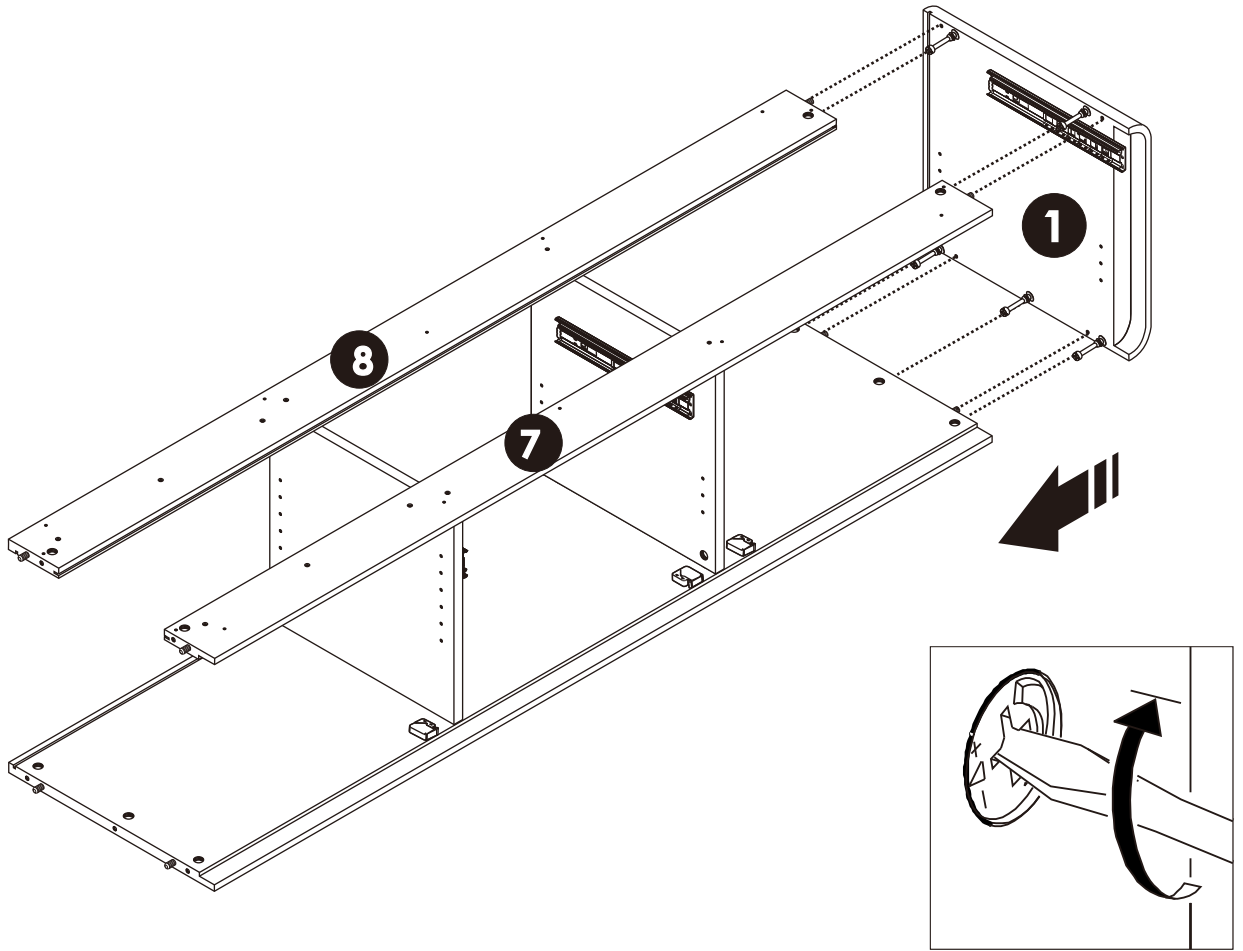

8.

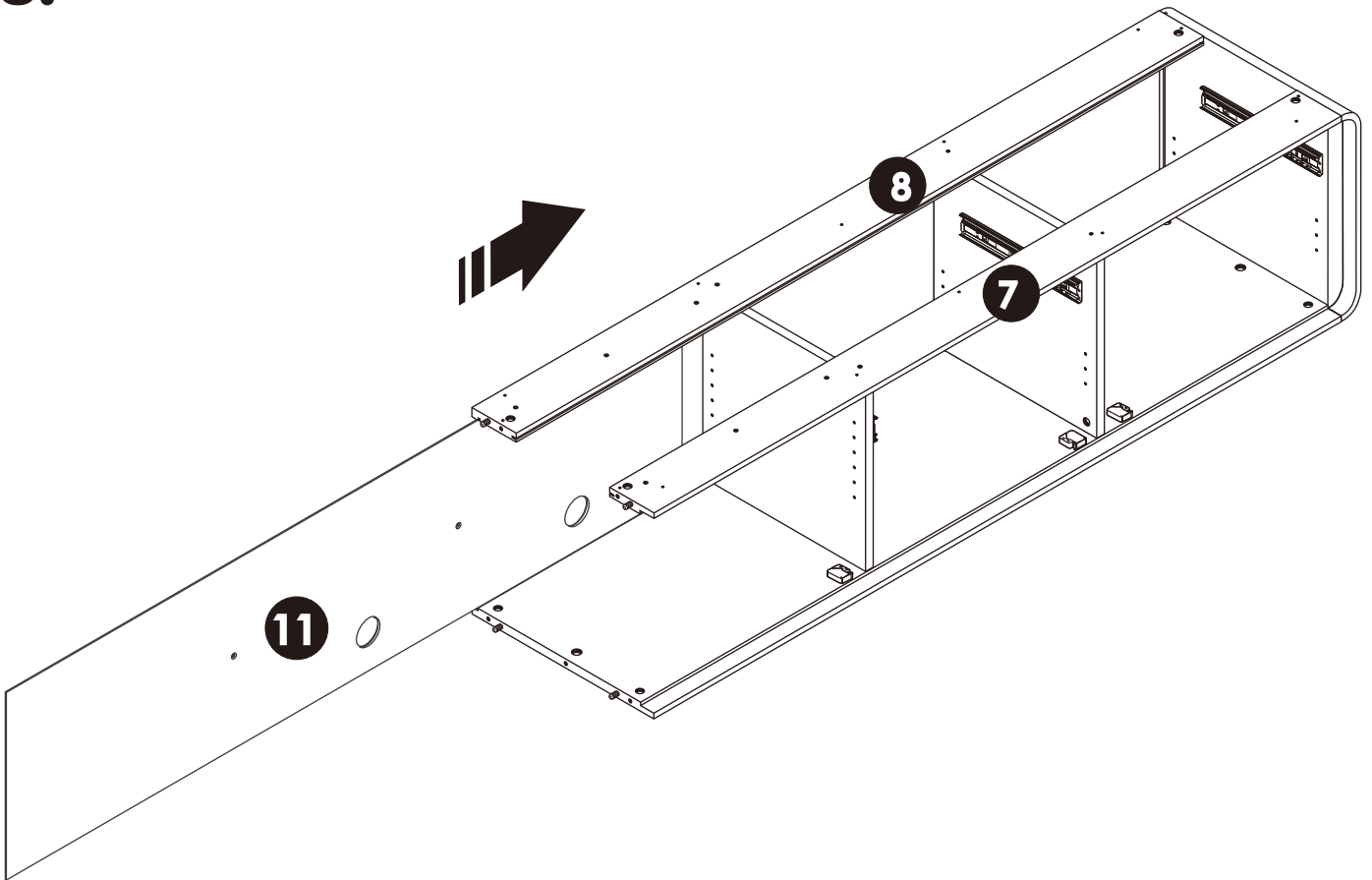

9.

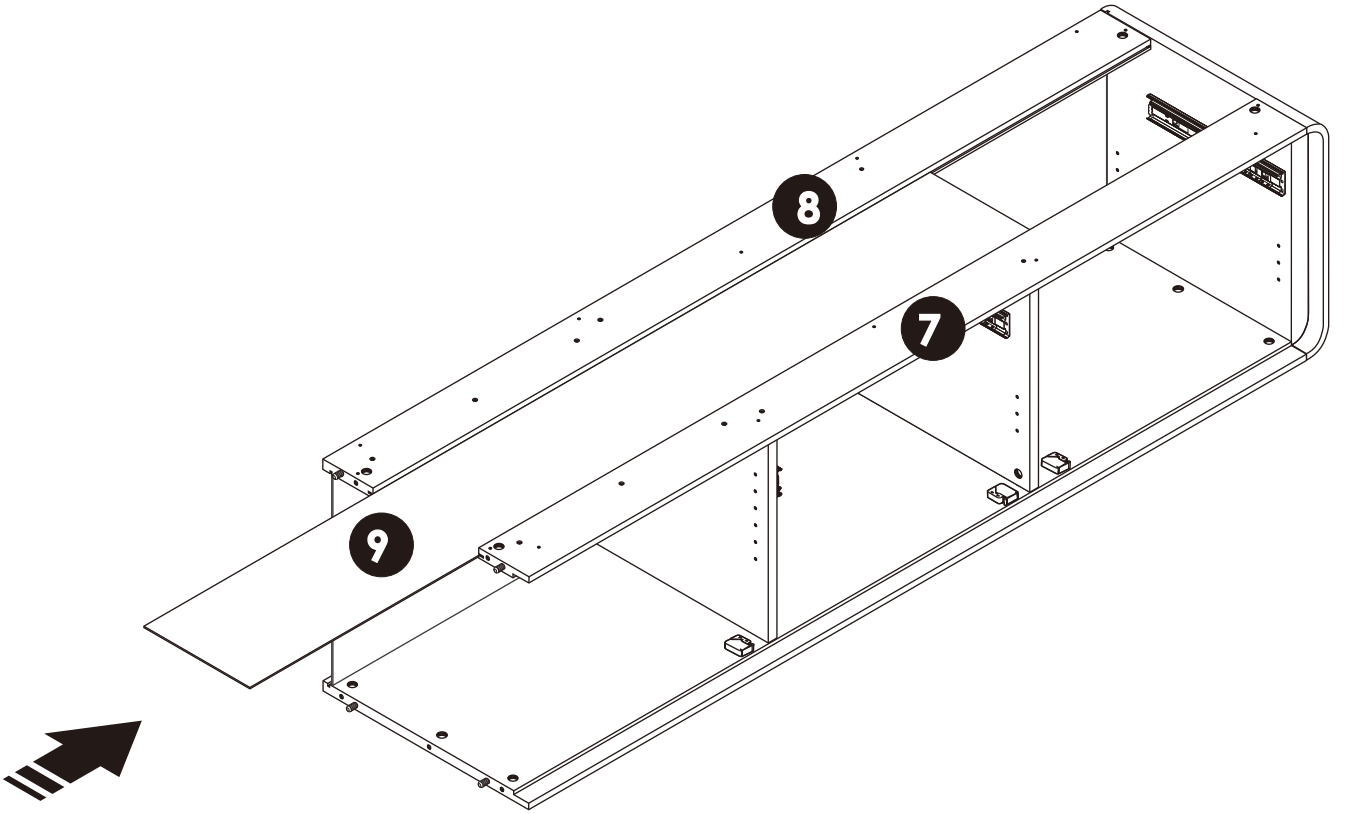

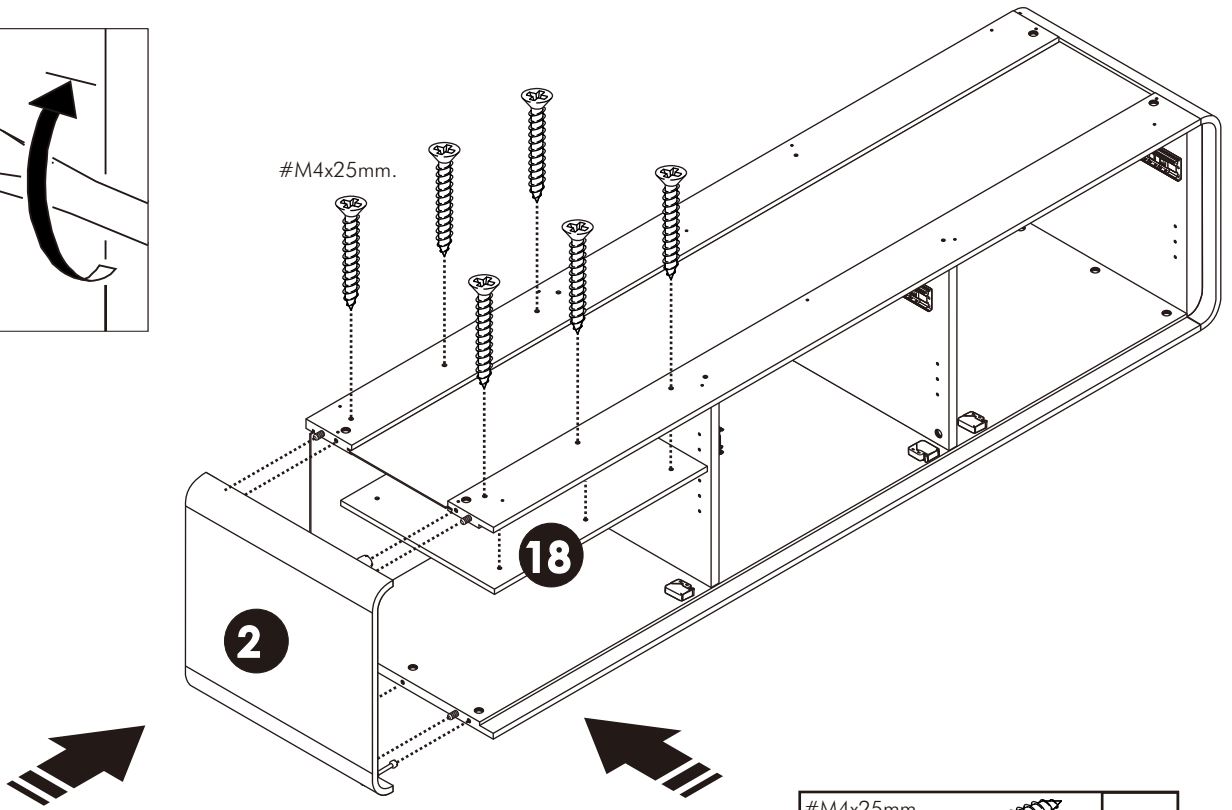
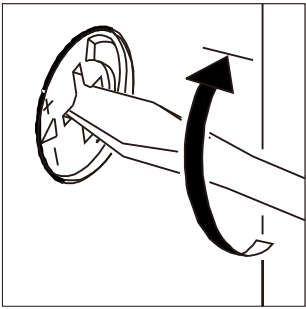

10.

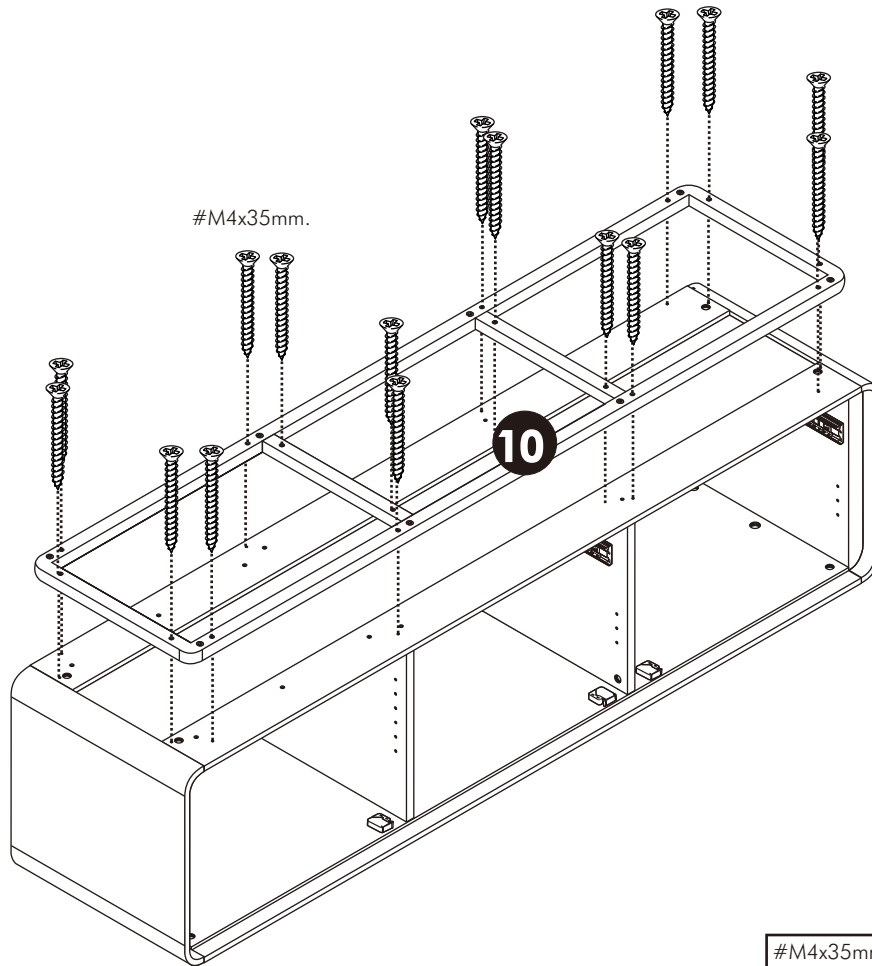

#M4x25mm.		x6
-----------	---	-----------

11.



#M4x35mm.		x16
-----------	---	------------

12.

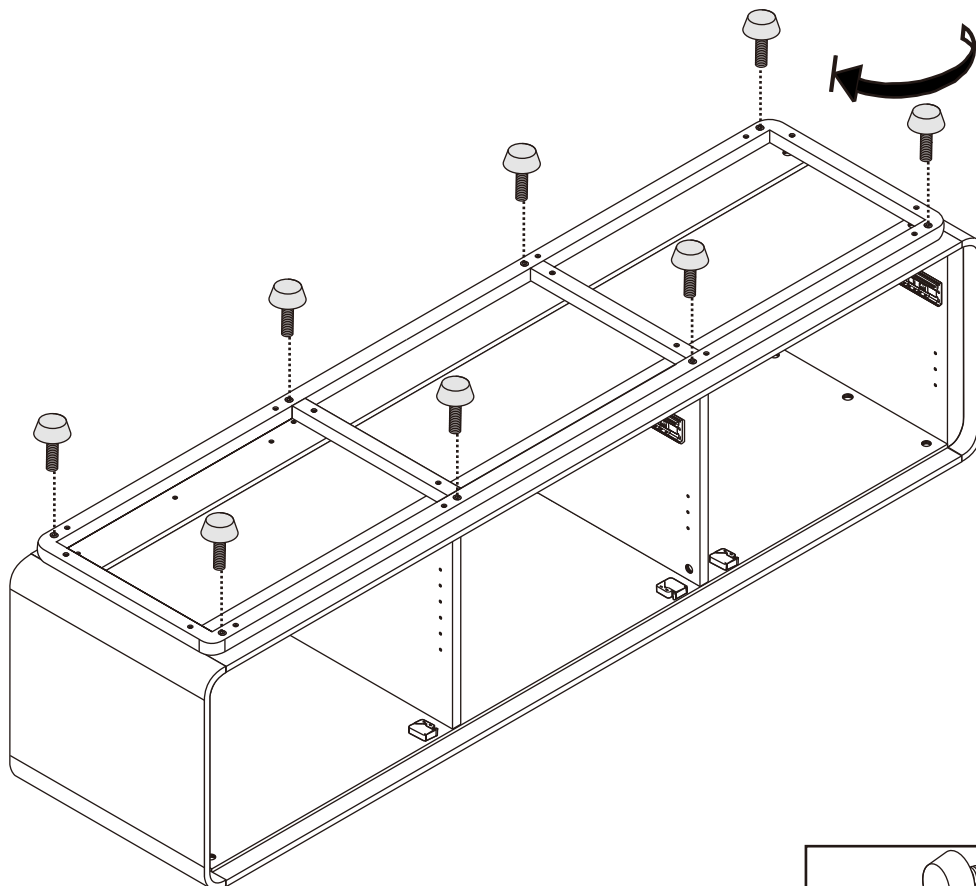

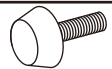
	x8
---	-----------

13.

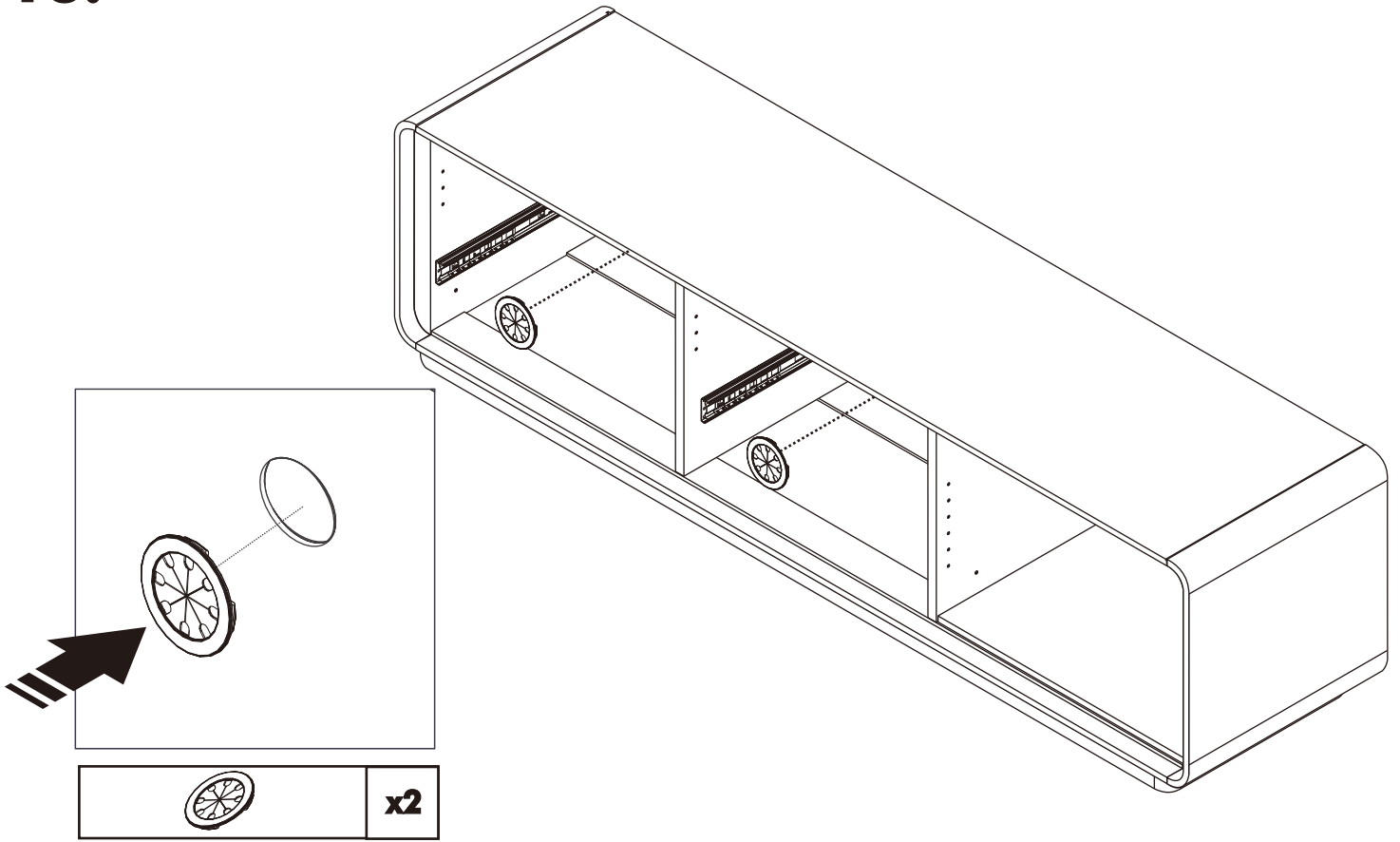

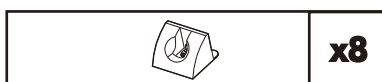
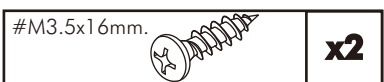
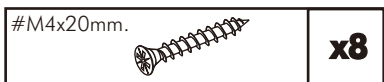
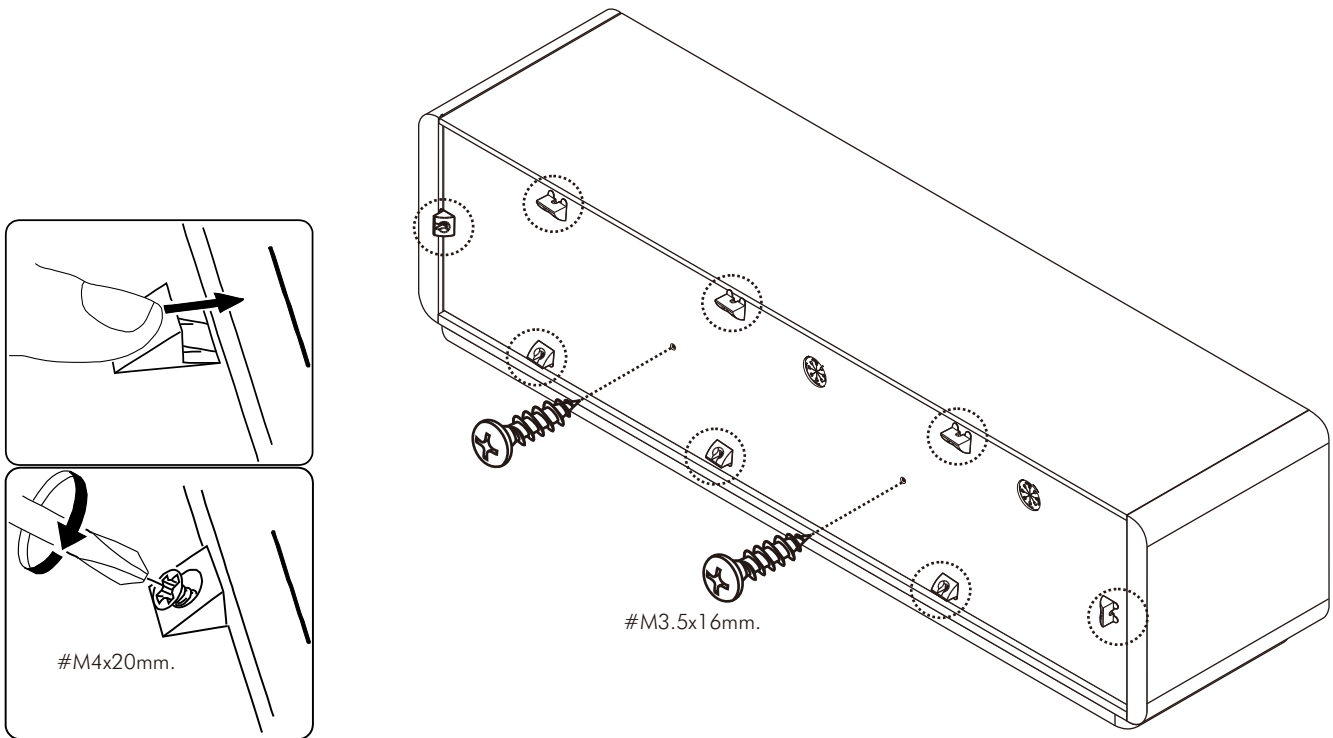

14.



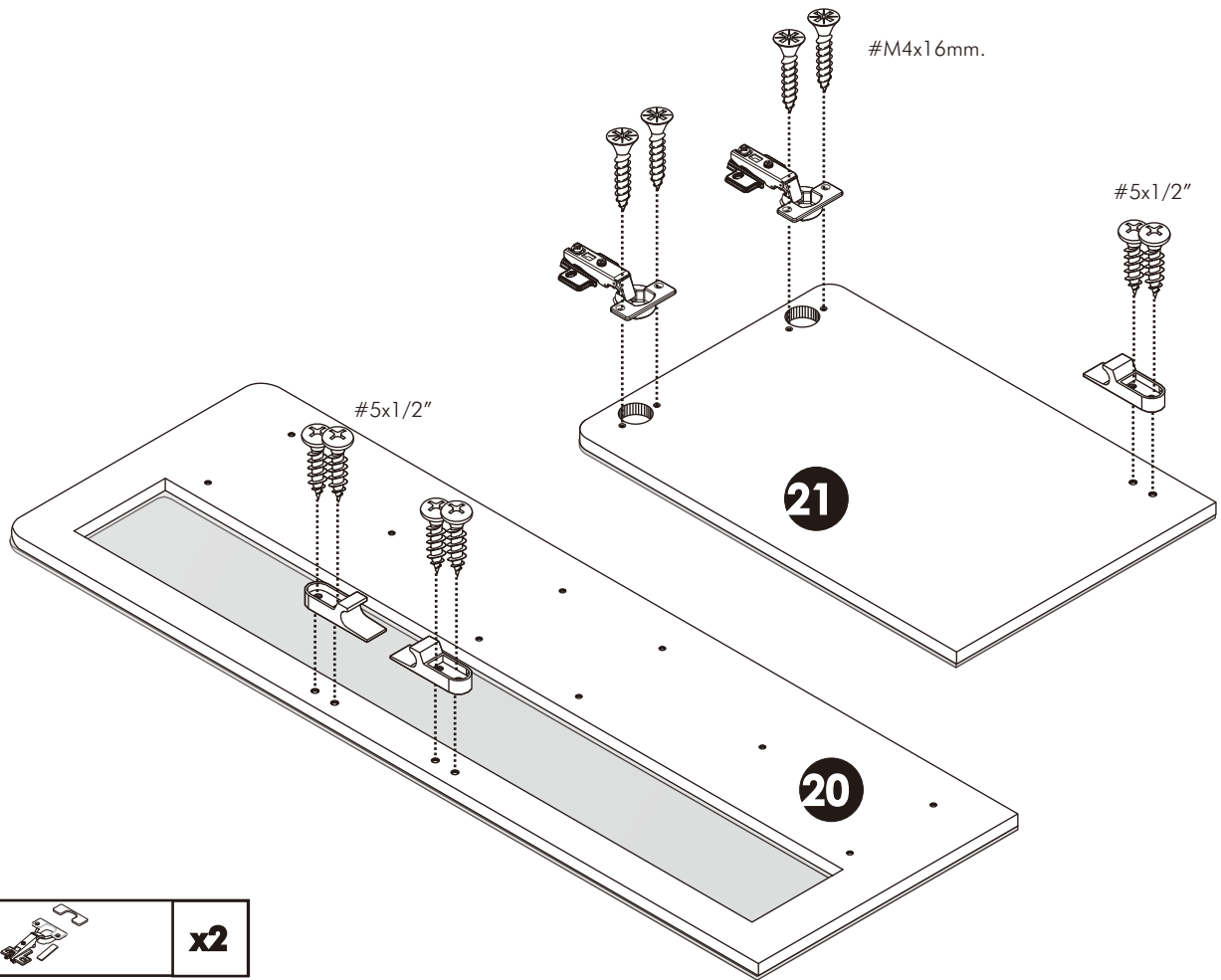

15.



	x2
--	-----------

#5x1/2" 	x6
---	-----------

#M4x16mm. 	x4
---	-----------

	x3
---	-----------

16.

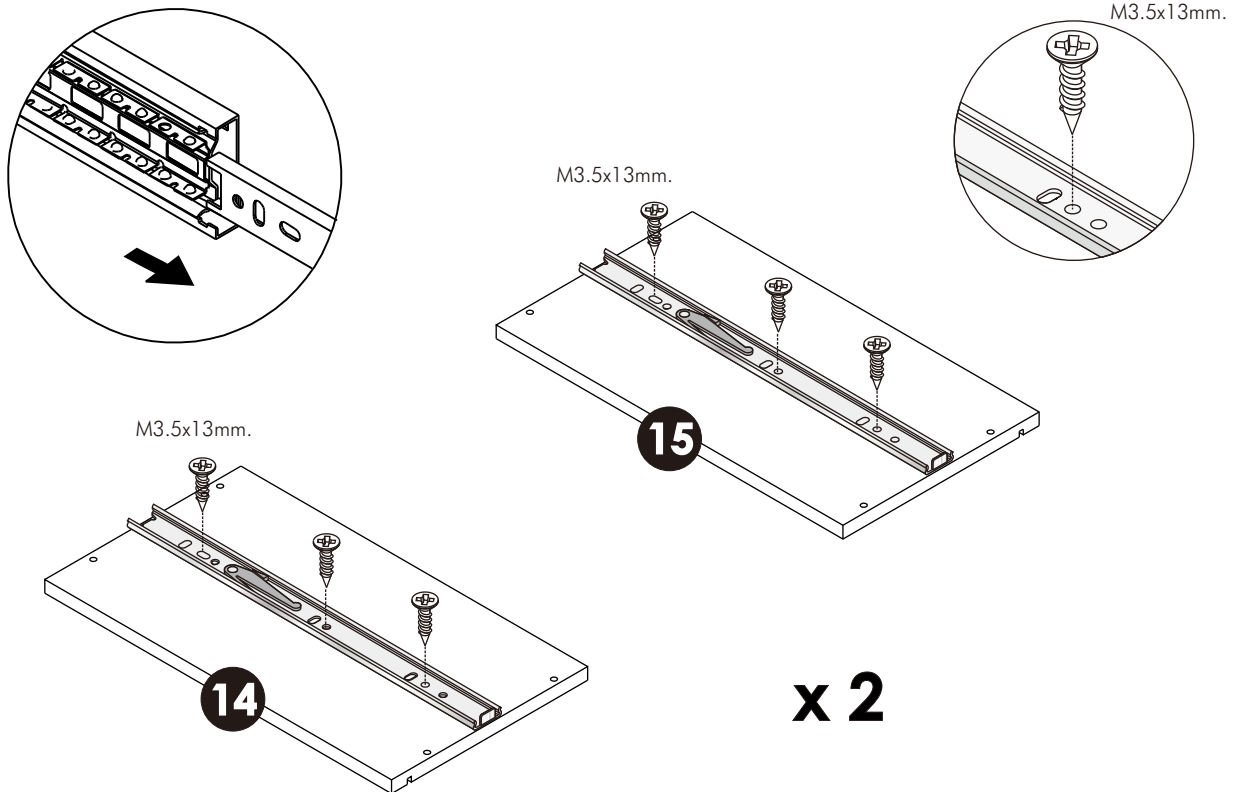

	x4
---	-----------

M3.5x13mm. 	x12
--	------------

17.

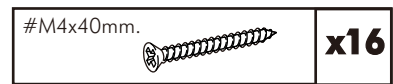
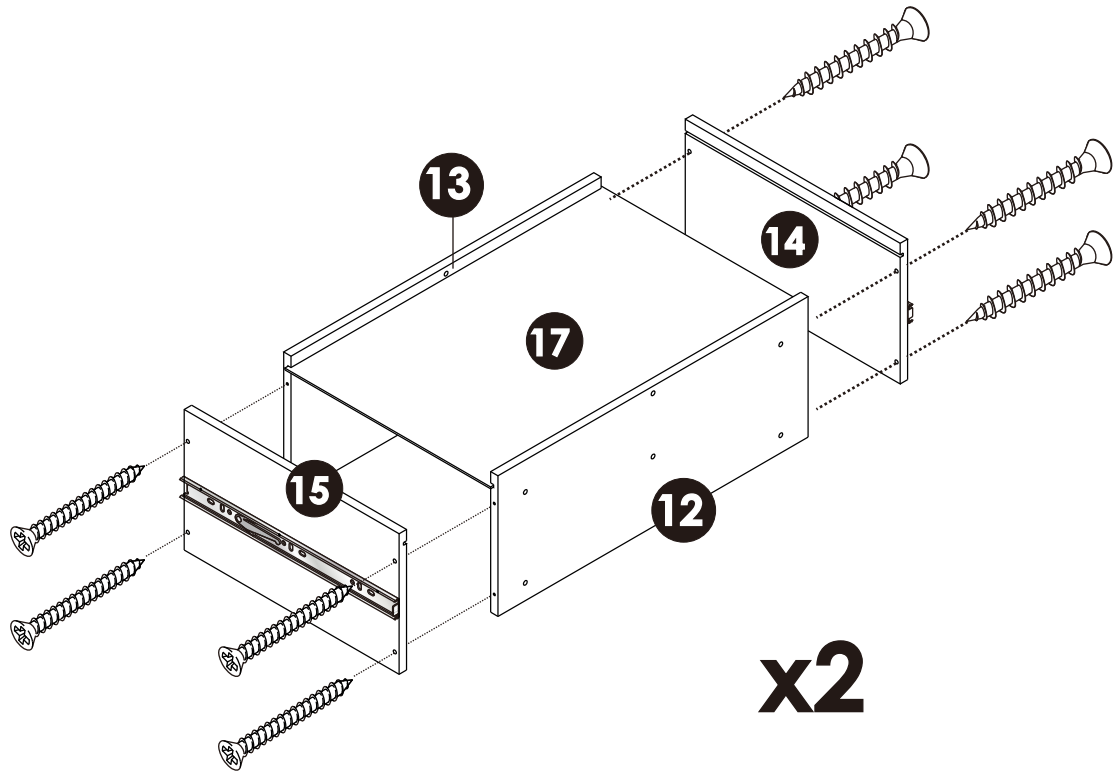

18.

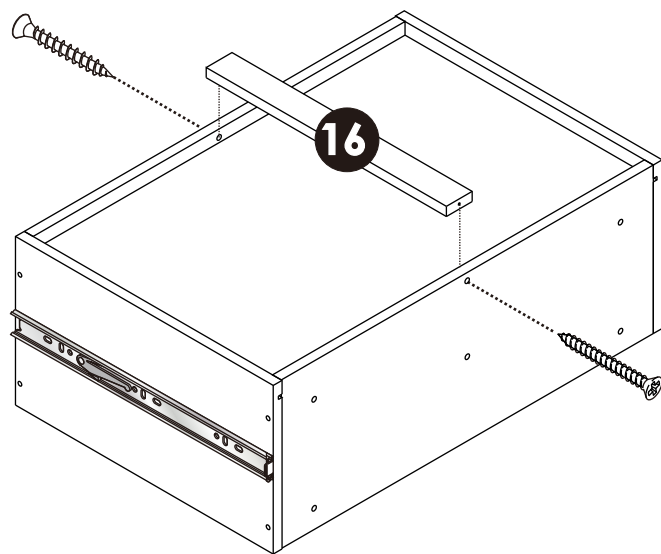

x2

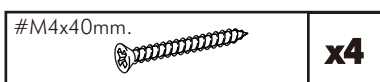

19.

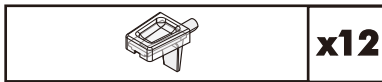
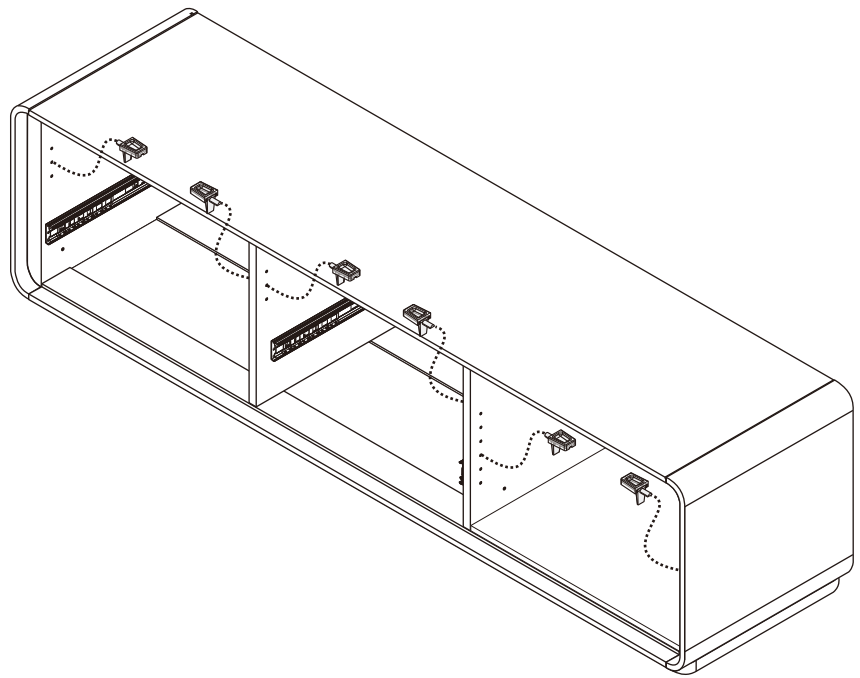
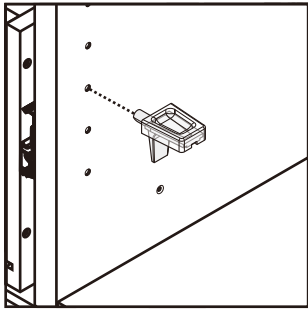
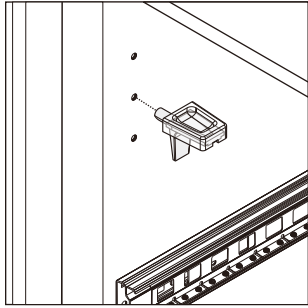

20.

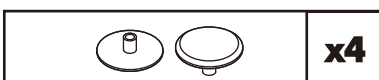
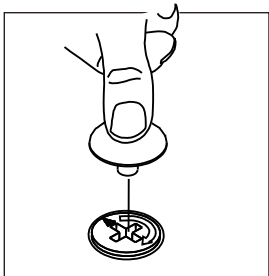
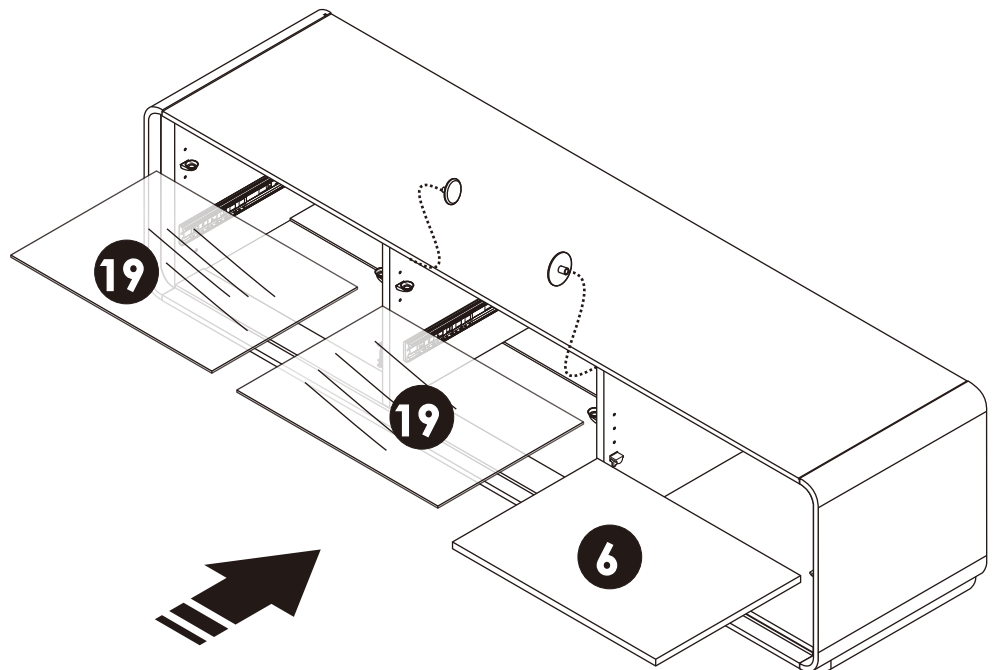

21.

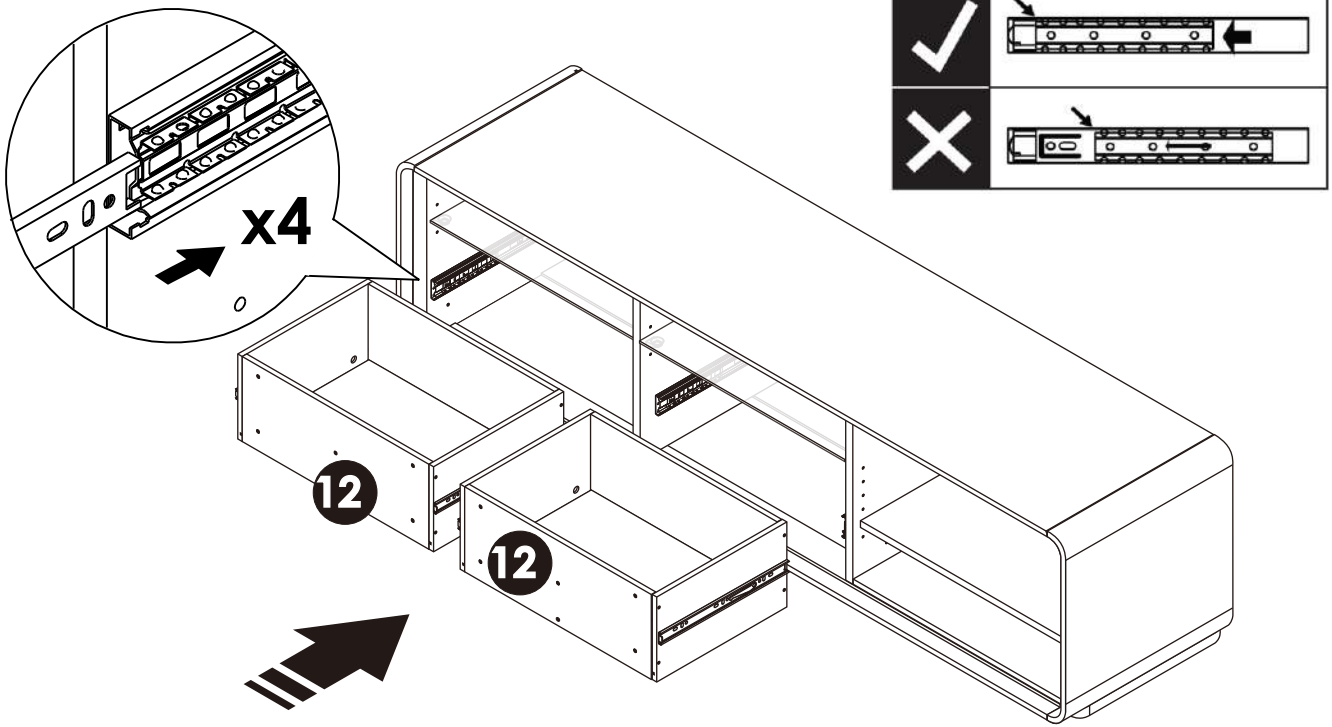

NOTE: Make sure ball bearings of glides on unit are positioned toward the front of the unit prior to inserting the drawer.

22.

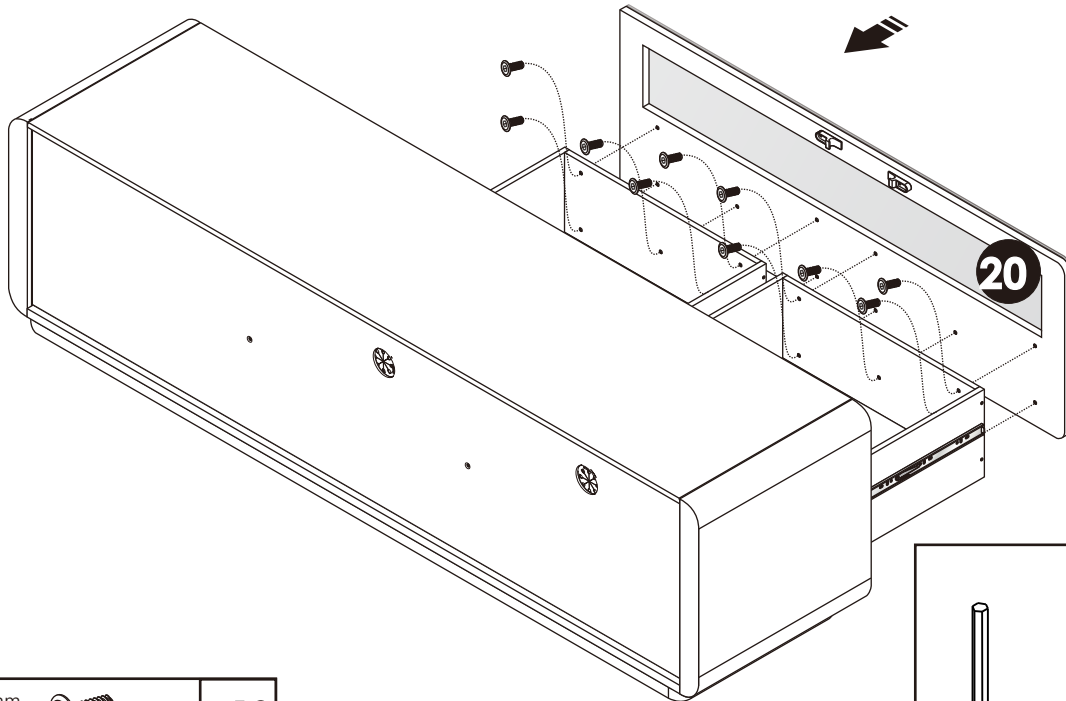

#M6x23mm.



x10

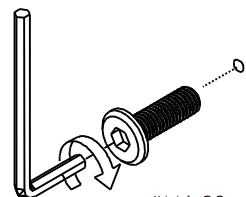

#M6x23mm.

23.

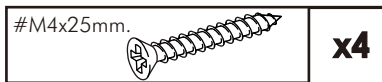
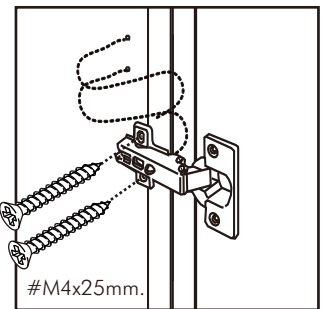
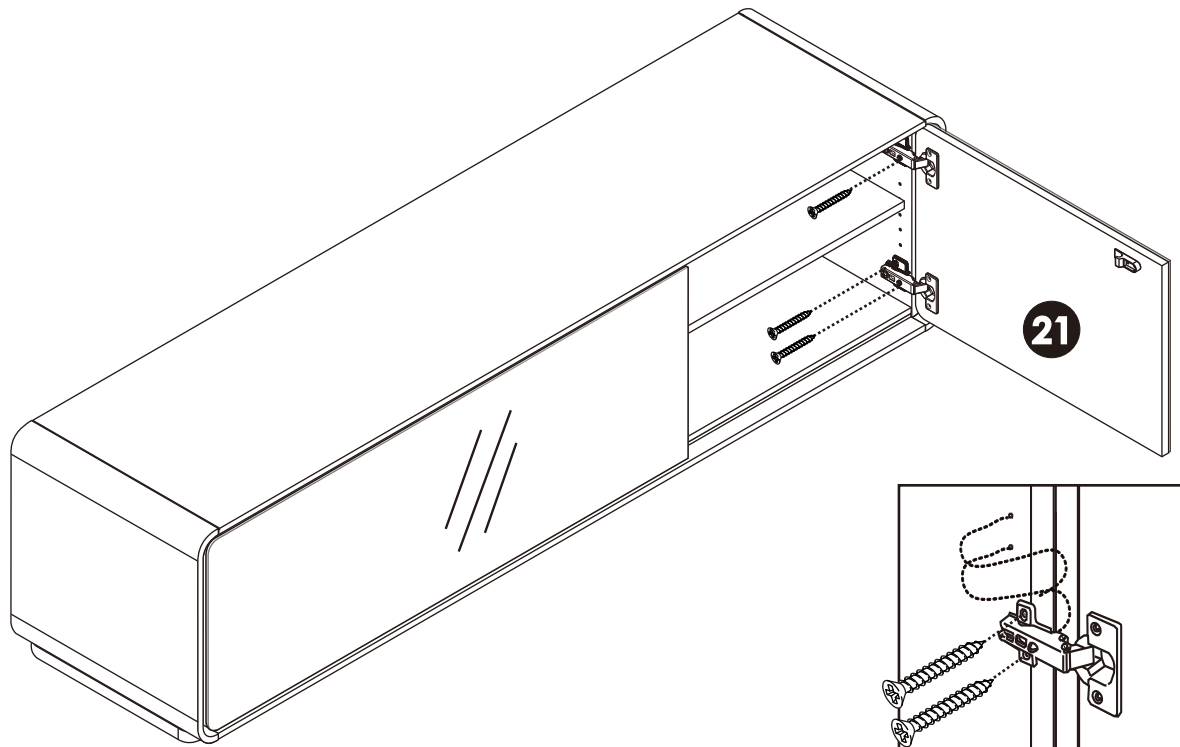

24.

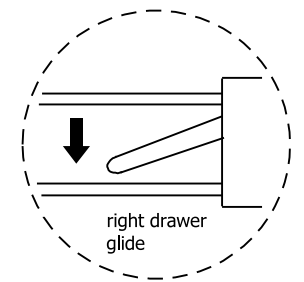
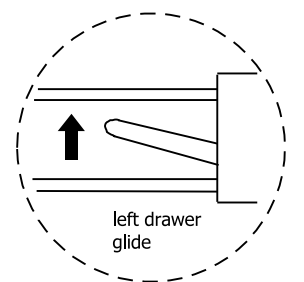
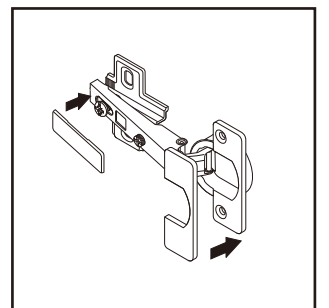
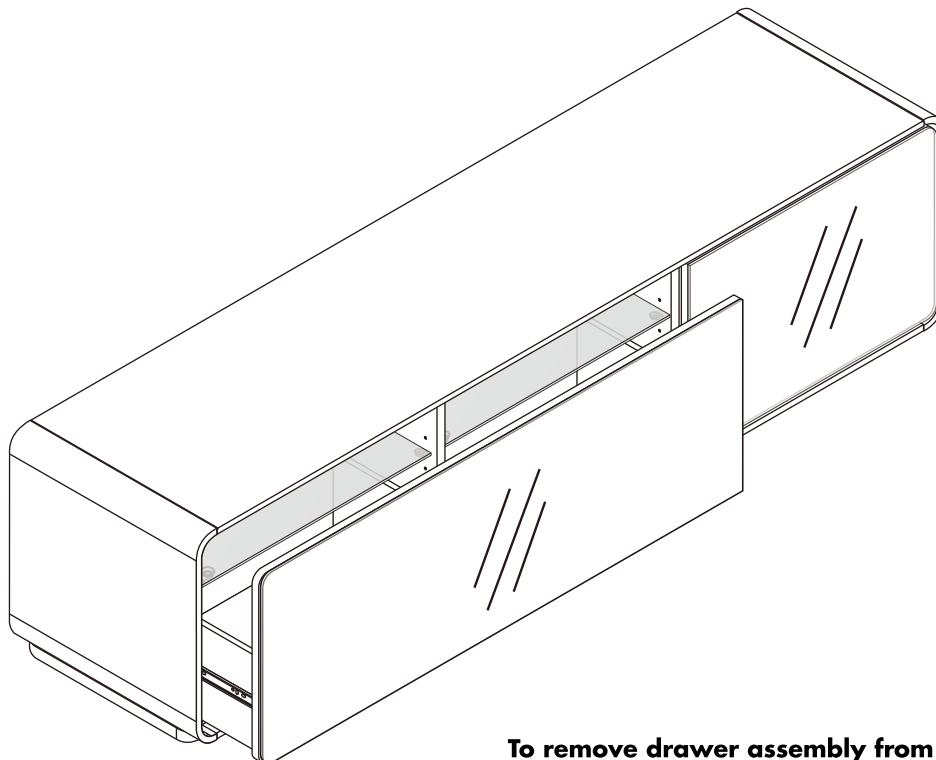

To remove drawer assembly from assembled unit:

Fully extend drawer assembly from unit. Locate plastic tabs on left and right drawer glides. With even pressure, simultaneously lift the left tab and push down the right tab and pull the drawer from the assembled unit. Assembly is now complete.