

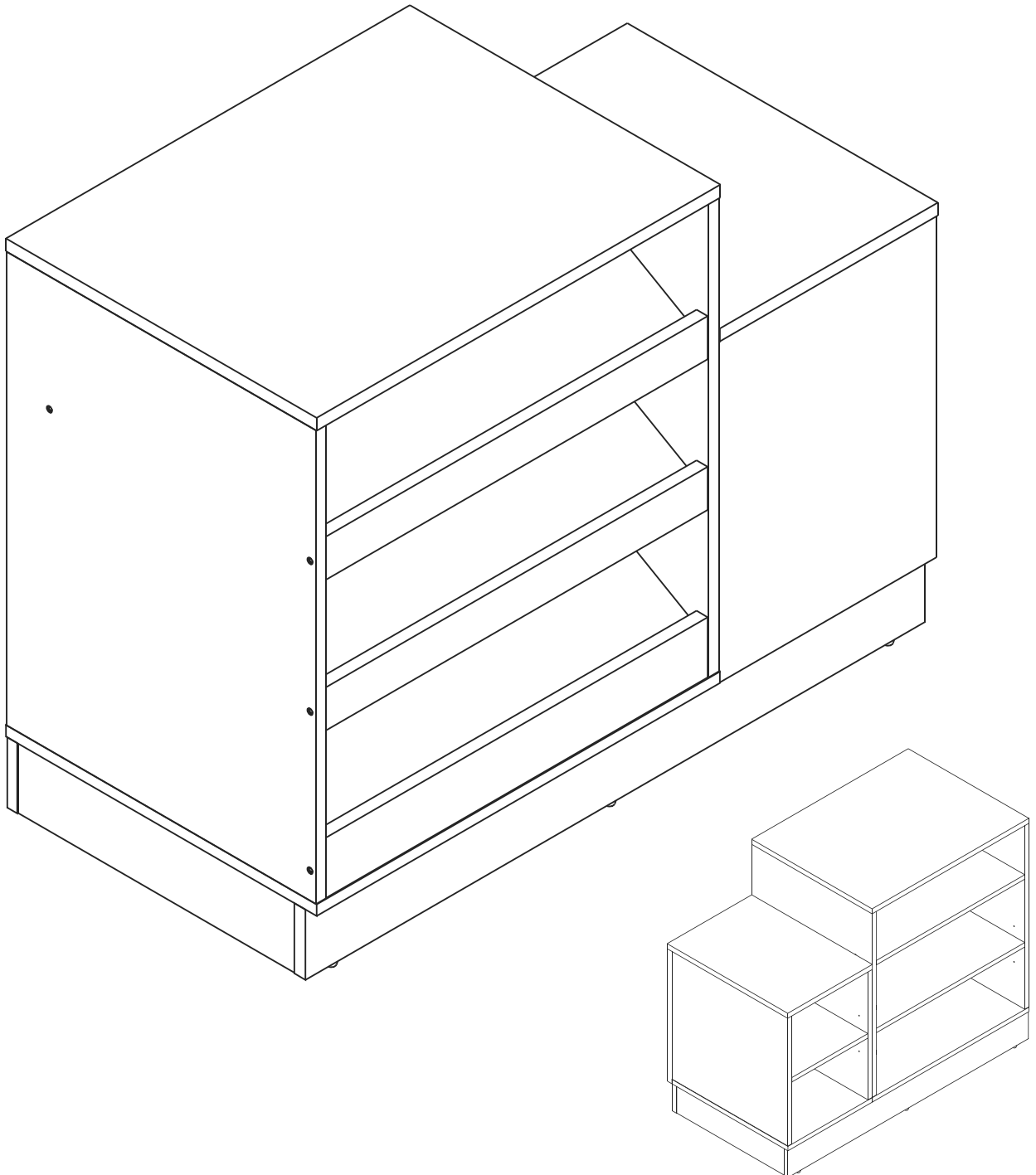

ถูก·ดี
มีมาตรฐาน

(N1R) เคาณเตอรดานหนา1



CONNECT SYSTEM

1

3

2

(Connecting bolts)

WHEN FITTING CAMS

ENSURE STARTING POSITION IS CORRECT
BEFORE YOU INSERT CONNECTING BOLT
TURN CLOCKWISE UNTIL SECURE

✓				✗
↑				
CORRECT		WRONG		

M4x16mm.

M4x30mm.

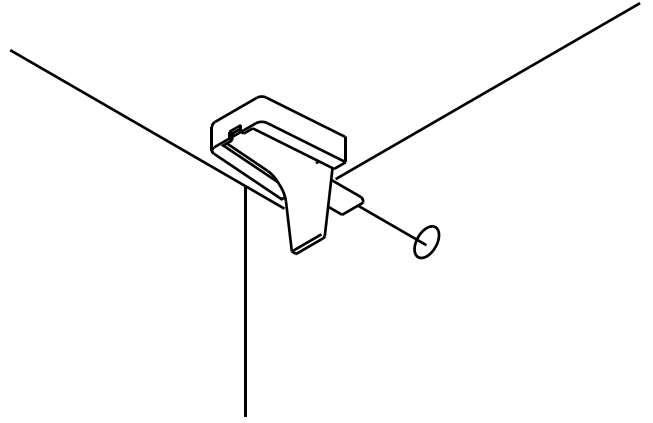
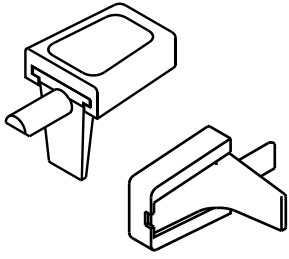

HARDWARE

-BODY SET

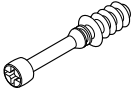

x 12



19mm.

x 12

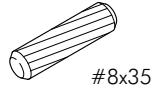

#8x35

x 60



x 8

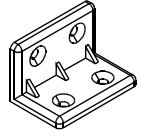

x 6



x 6



x 6



x 10

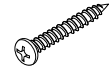

M4x30mm.

x 28



M4x16mm.

x 24

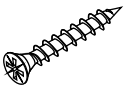

M4x25mm.

x 8

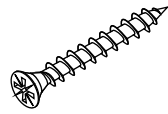

M3.5x35mm.

x 3

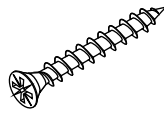

M4x40mm.

x 20

ASSEMBLY

-BODY SET

1.

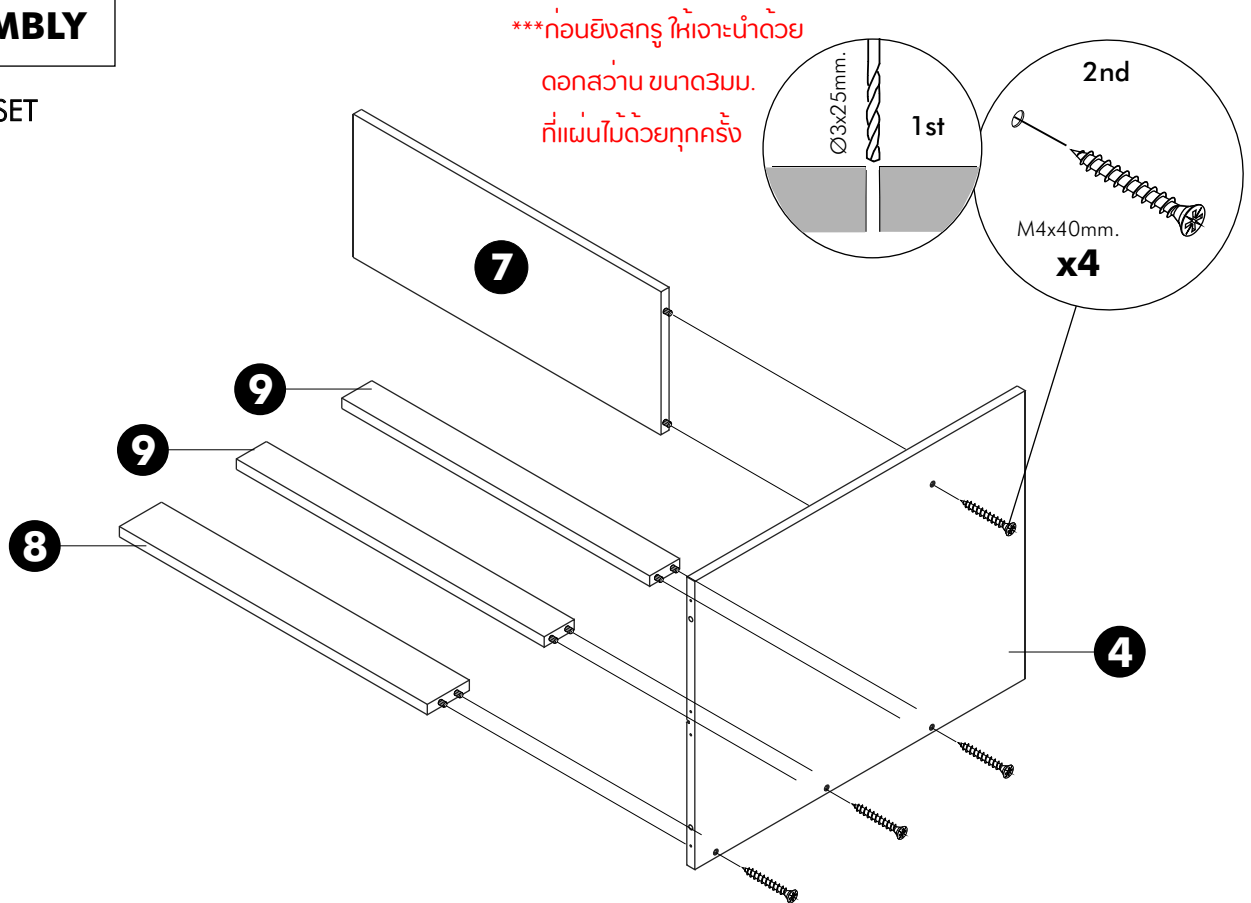

2.

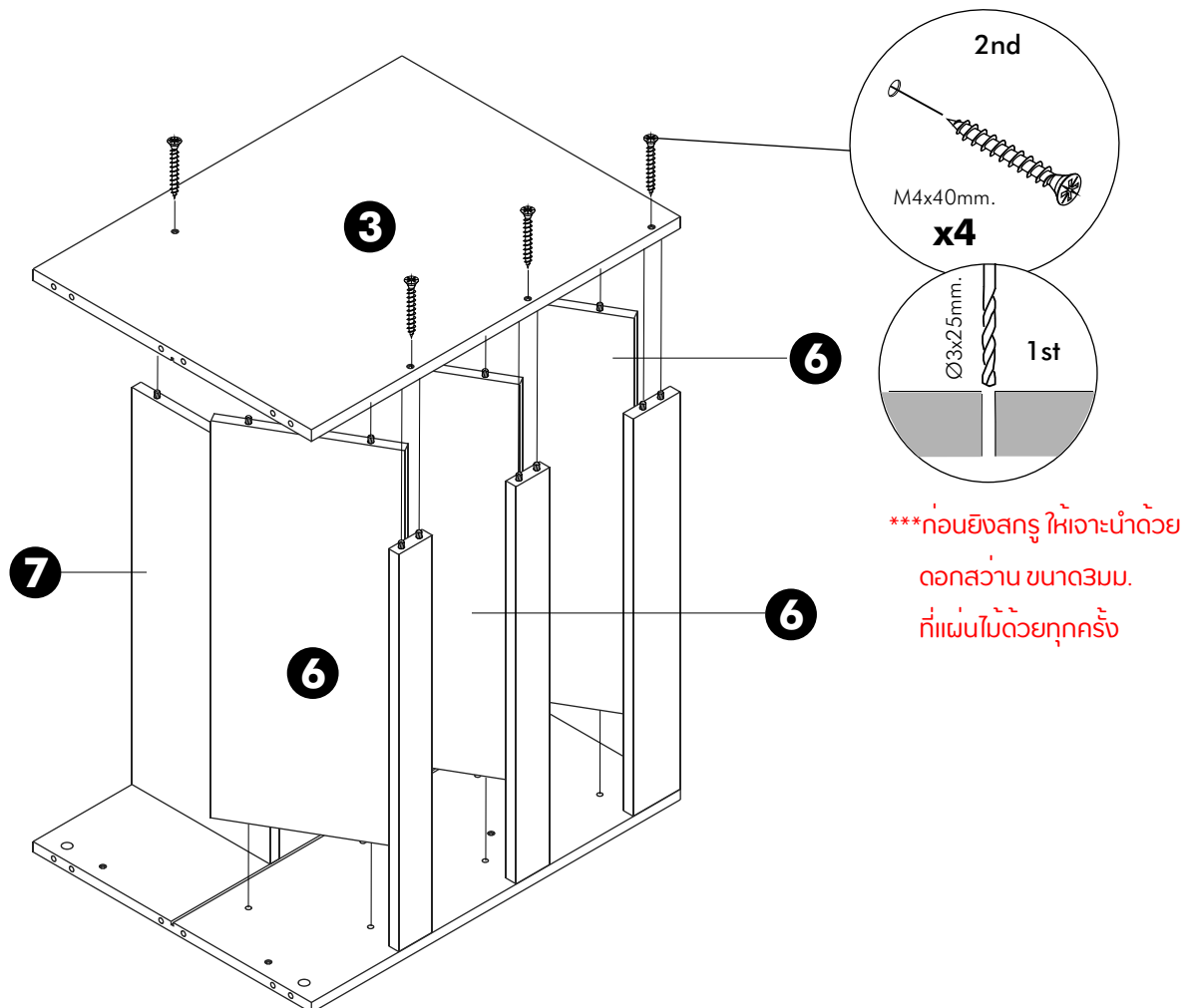

3.

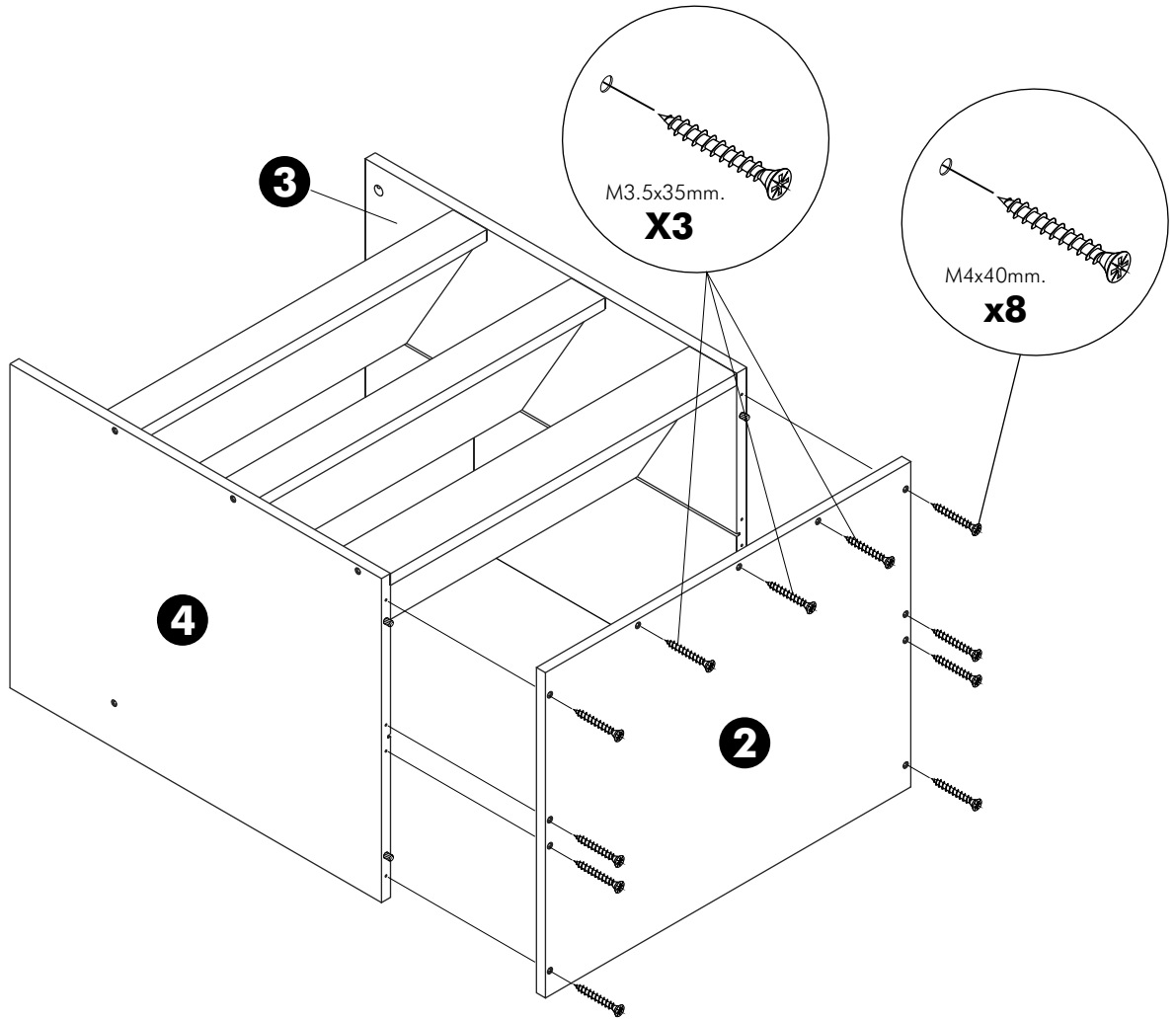

4.

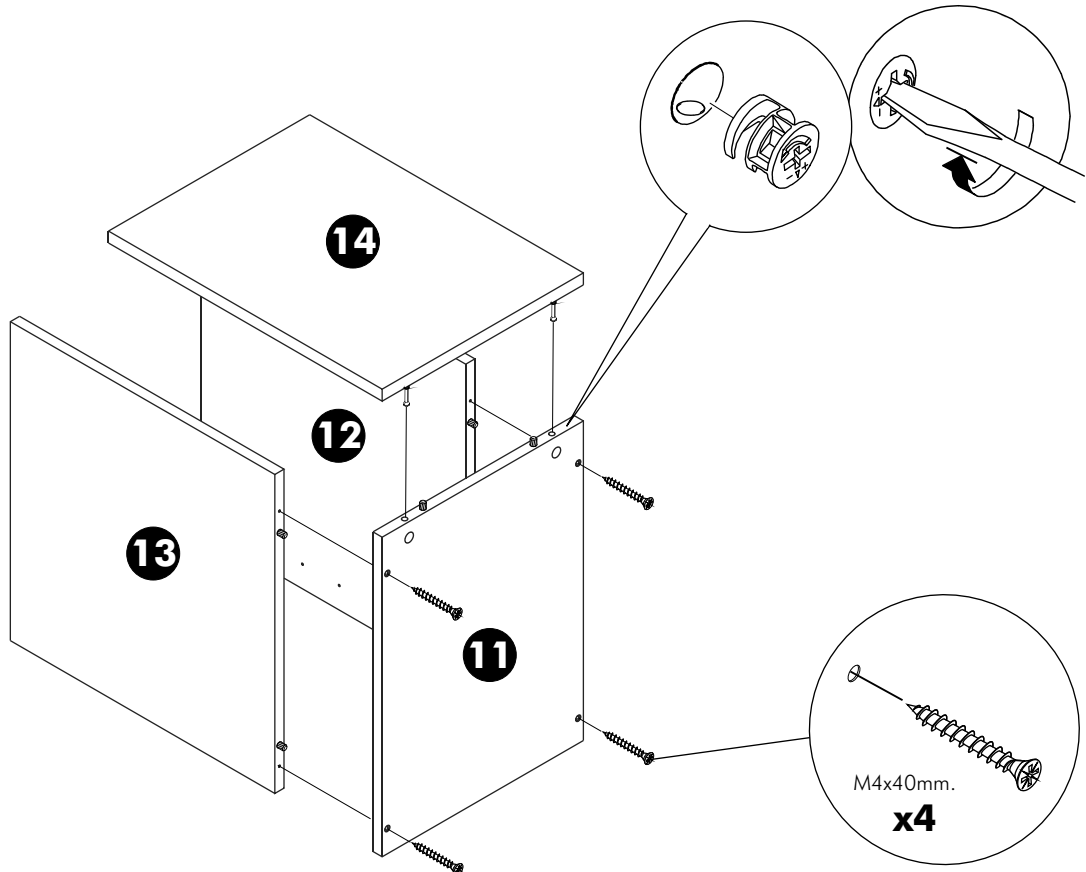

5.

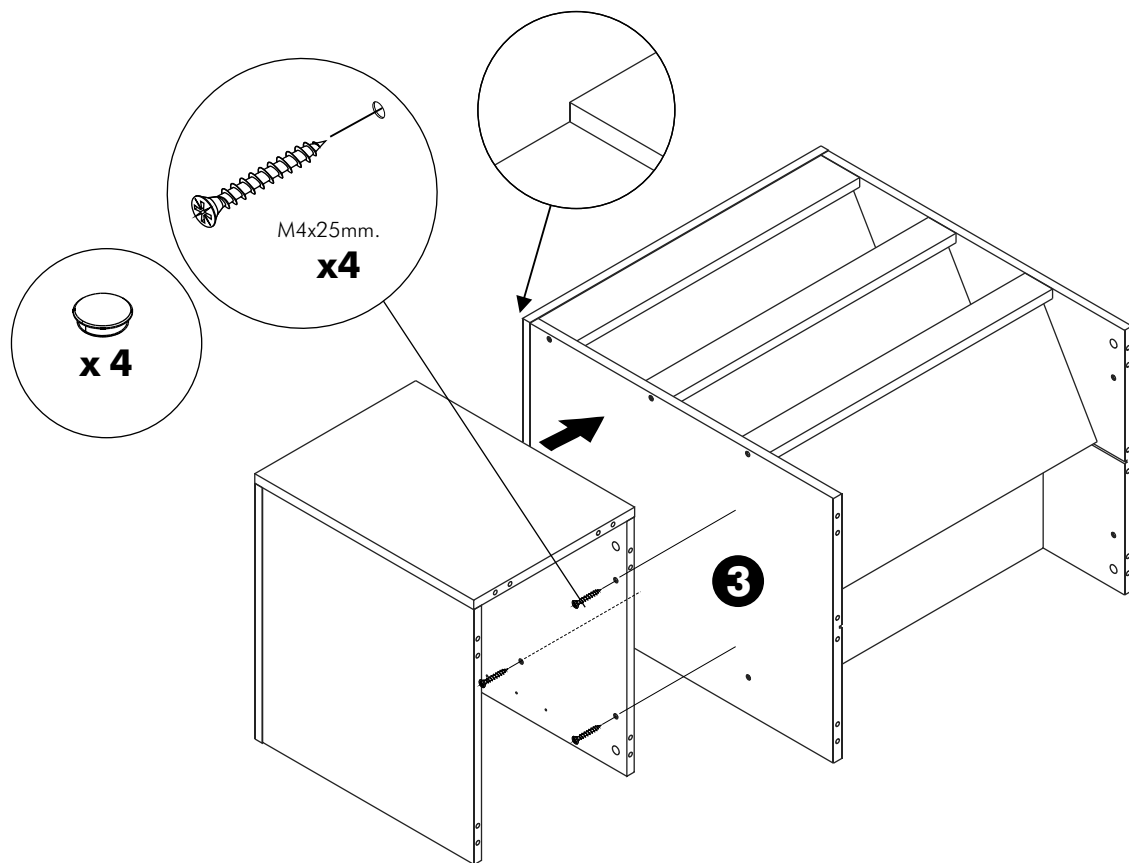

6.

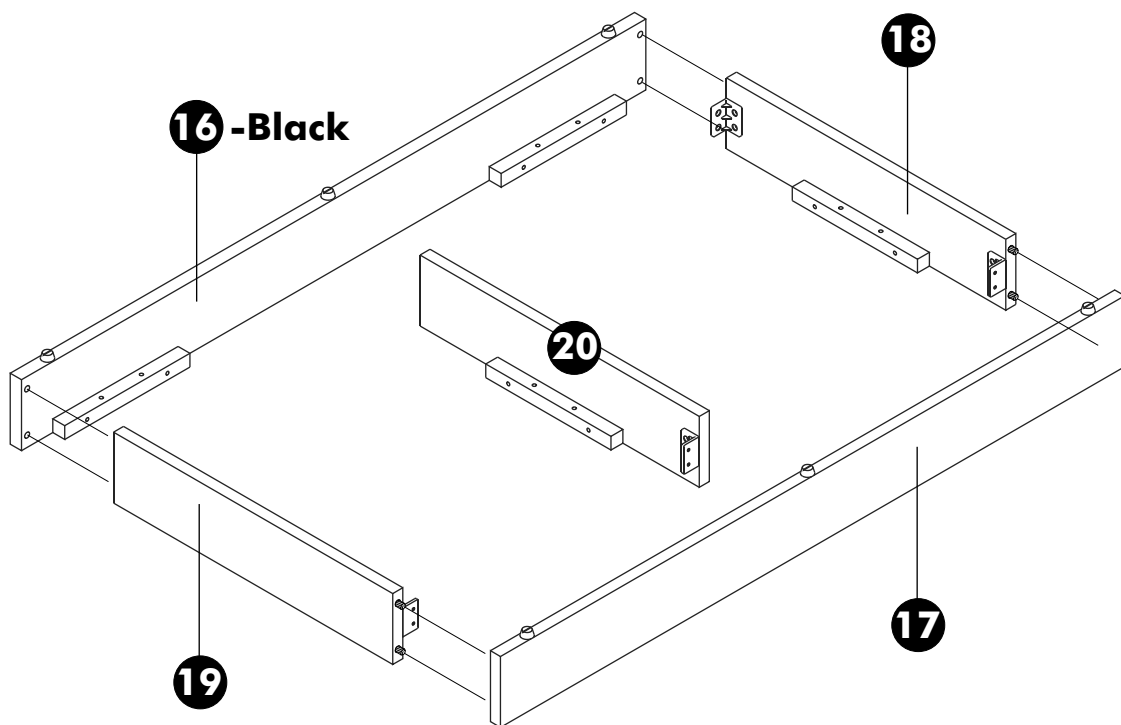

7.

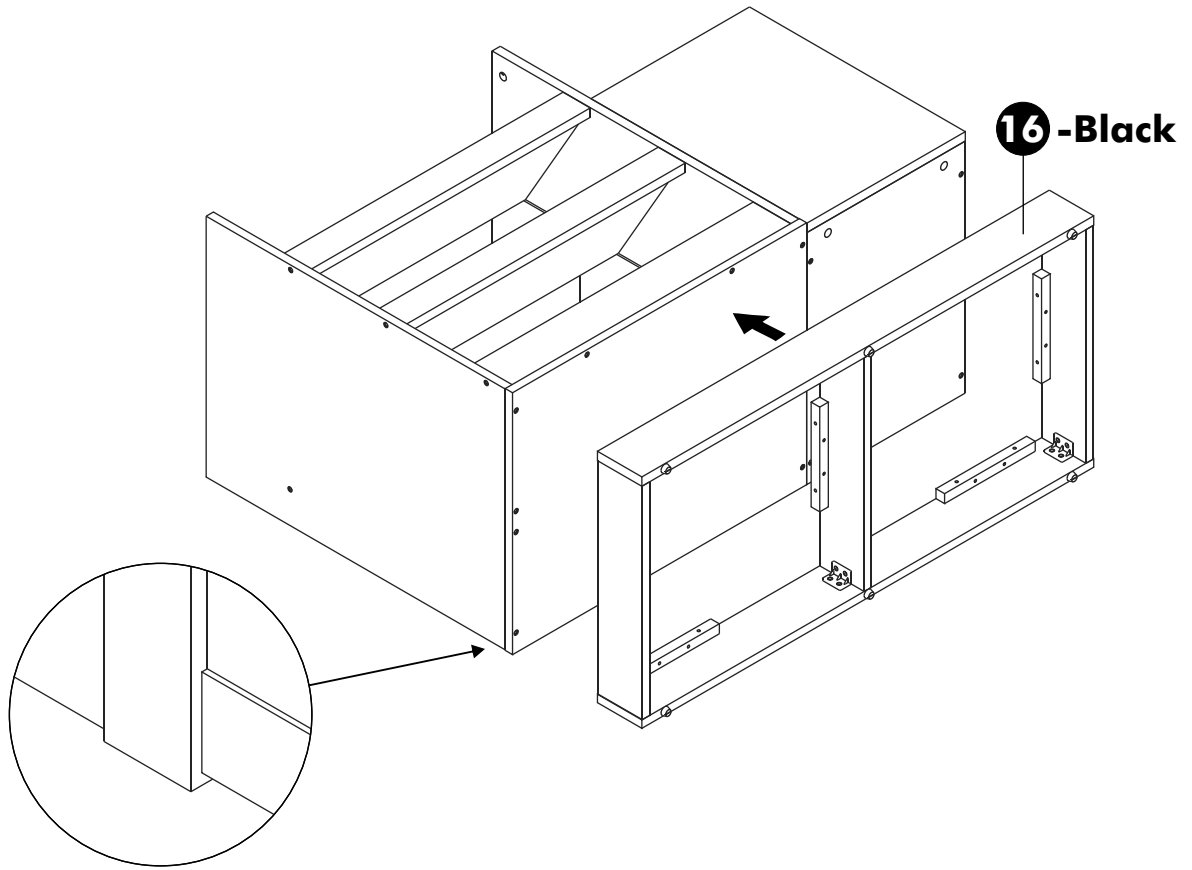

8.

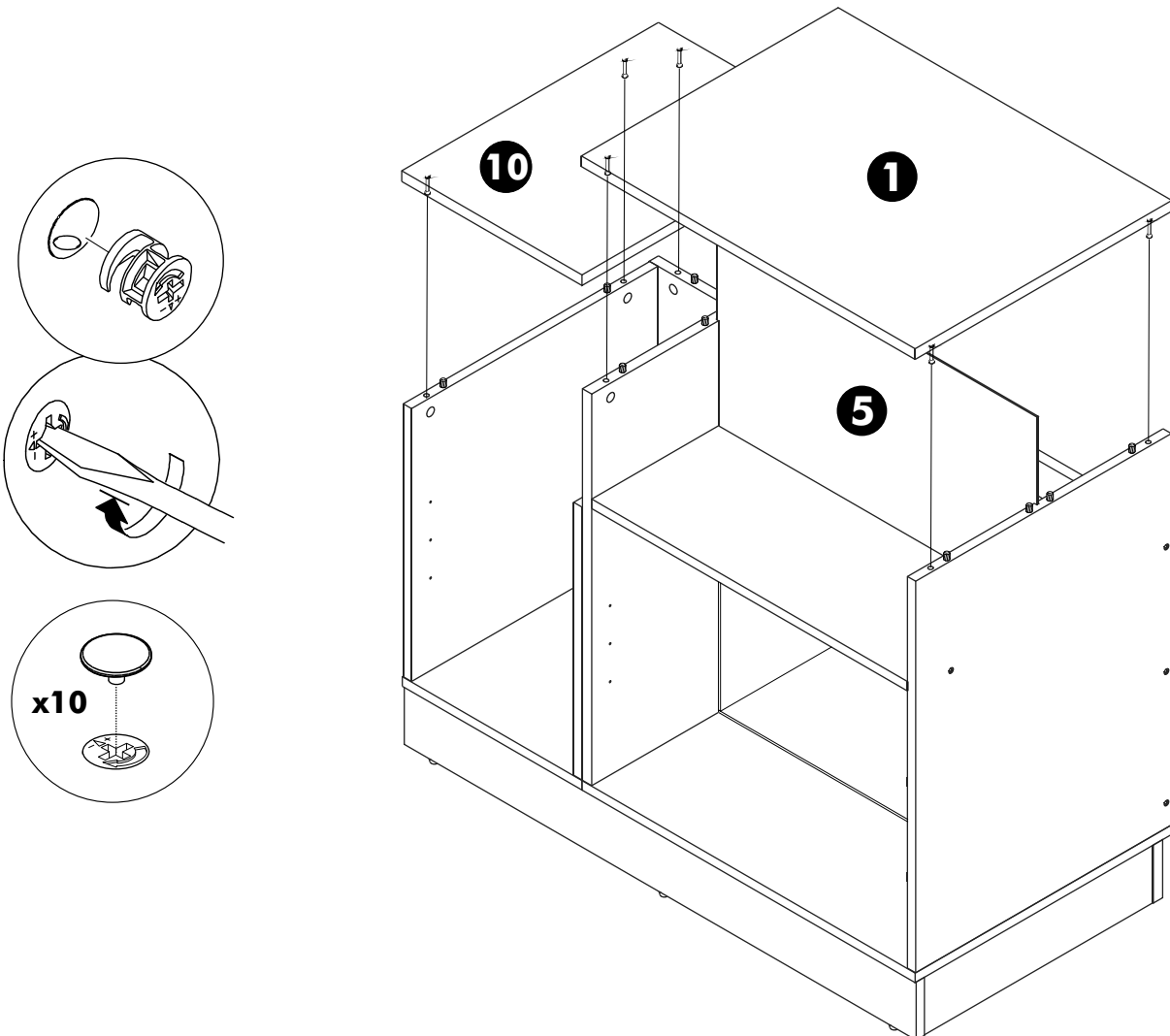

9.

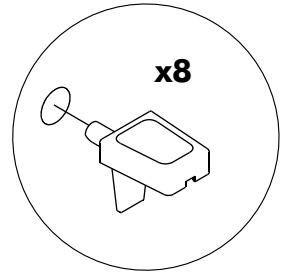
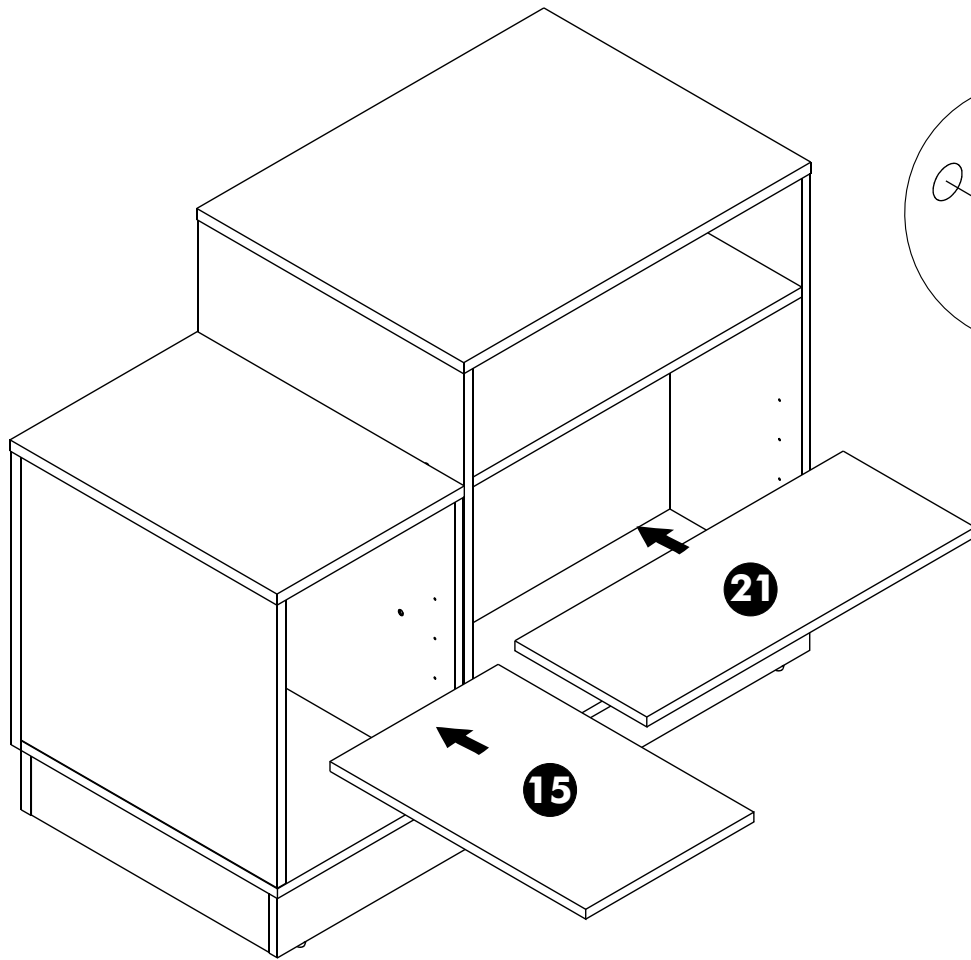

(N4R) เคาน์เตอร์ด้านหน้า4

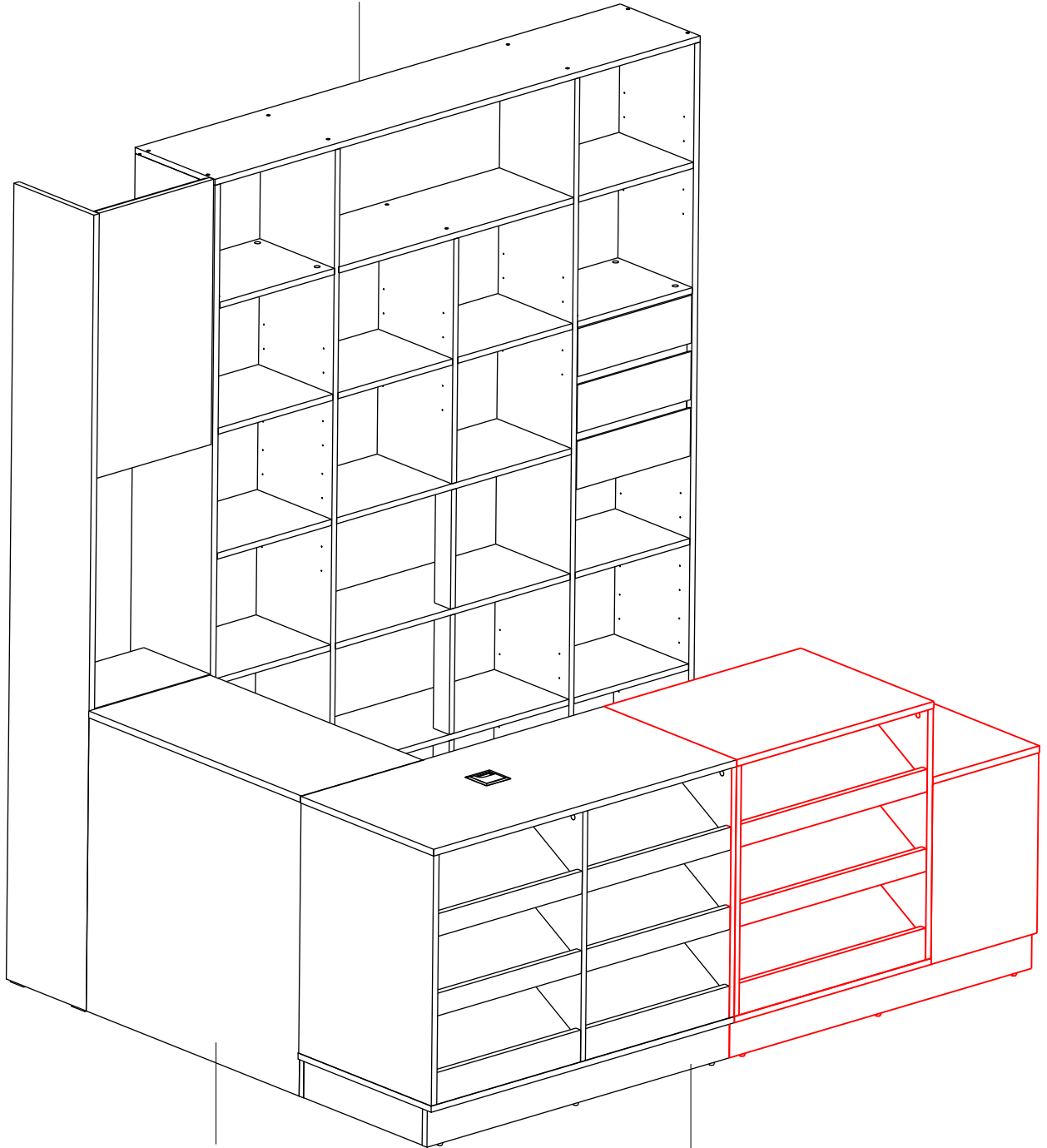

(N3) เคาน์เตอร์ด้านข้าง3

(N2R) เคาน์เตอร์ด้านหน้า2