

MAISON

Bedside cabinet 2 DW WT

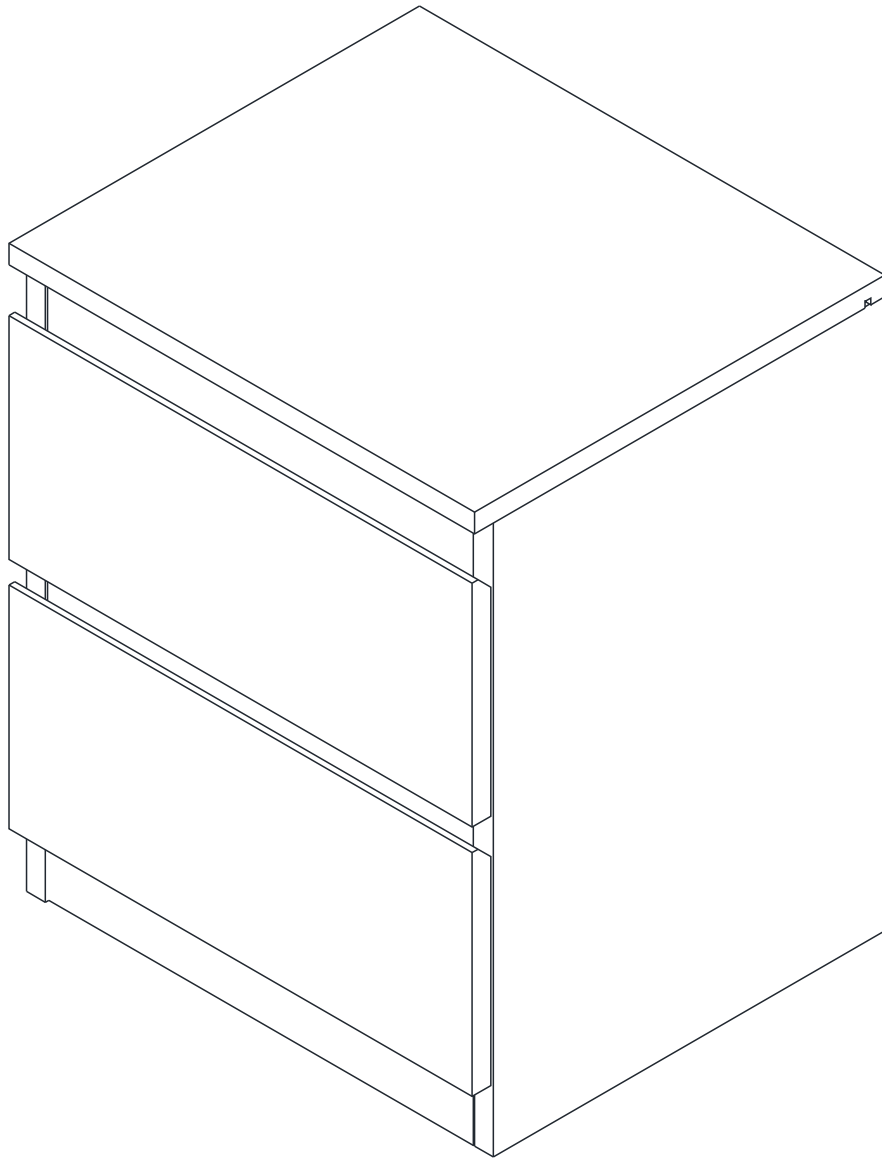

CONNECT SYSTEM

1

3

2

(Connecting bolts)

WHEN FITTING CAMS
 ENSURE STARTING POSITION IS CORRECT
 BEFORE YOU INSERT CONNECTING BOLT
 TURN CLOCKWISE UNTIL SECURE

✓				✗
↑				
CORRECT		WRONG		

M4x16mm.

i

M3.5x13mm.

1

28mm.

2

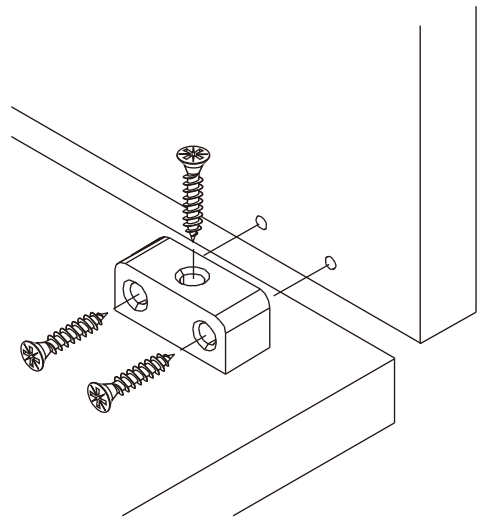
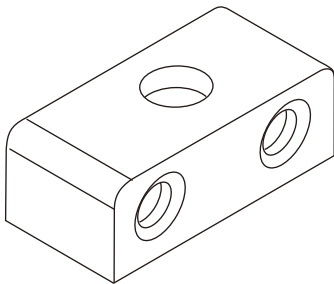
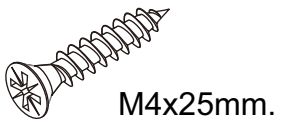
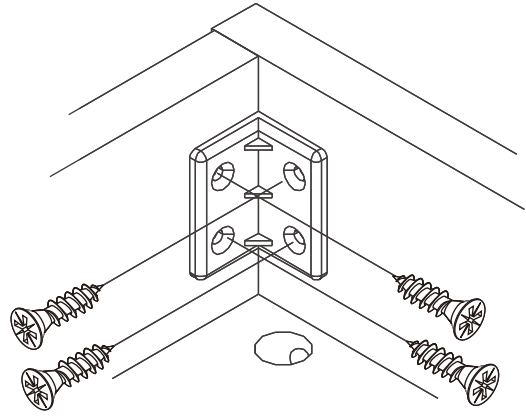
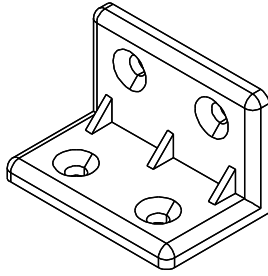

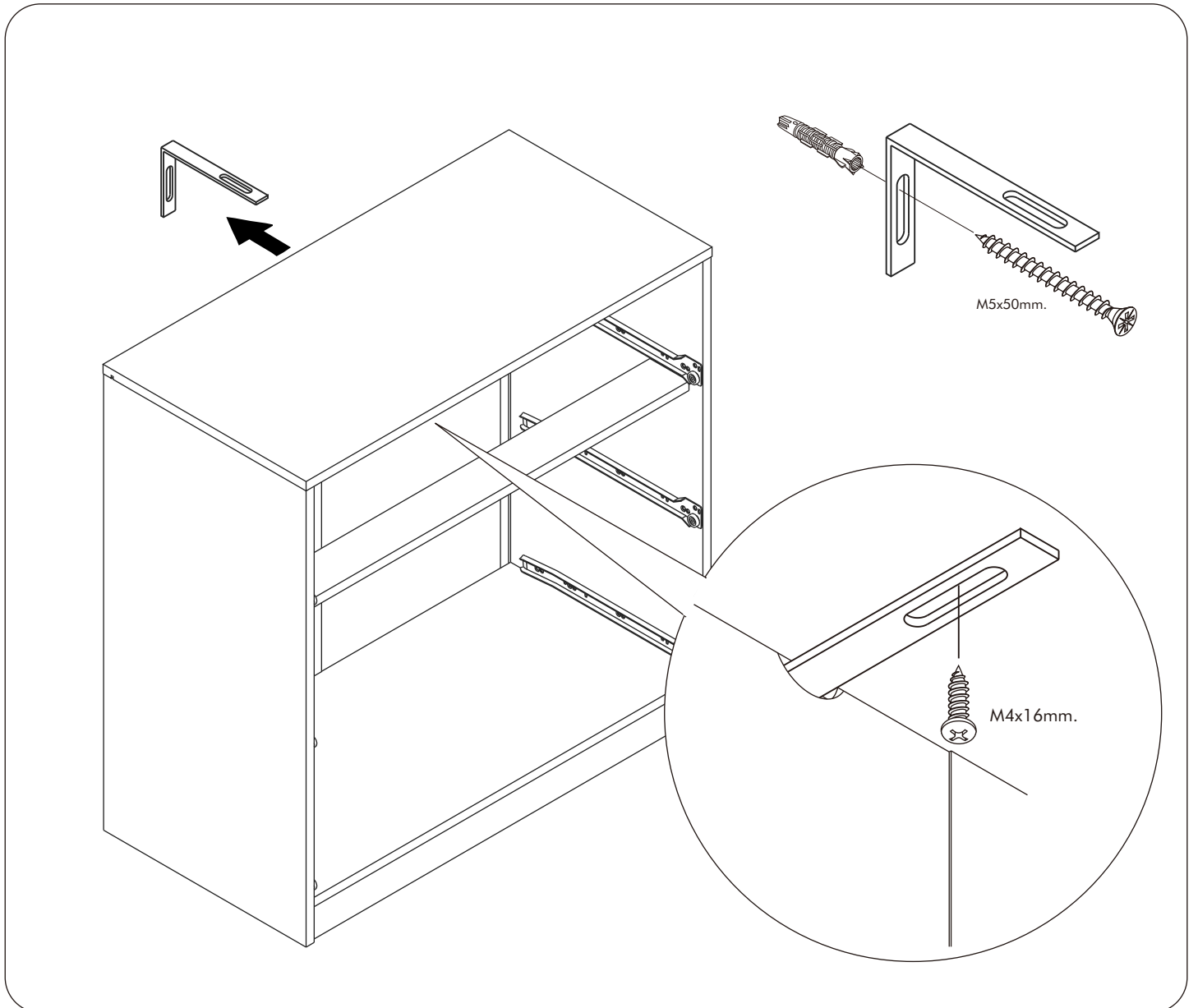
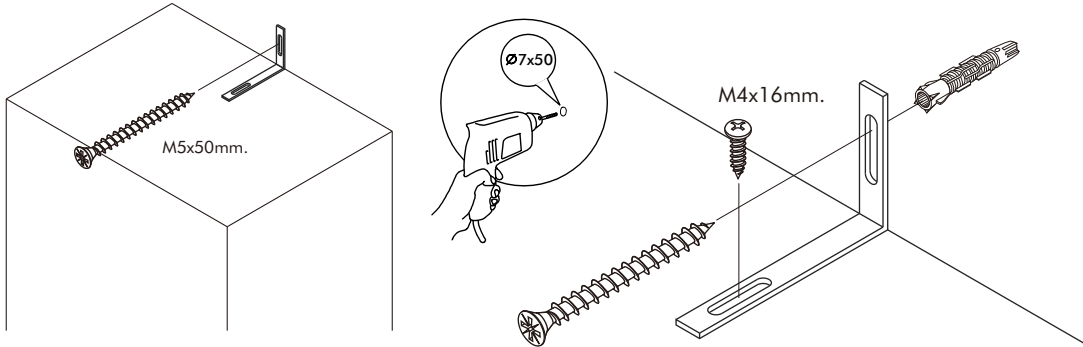
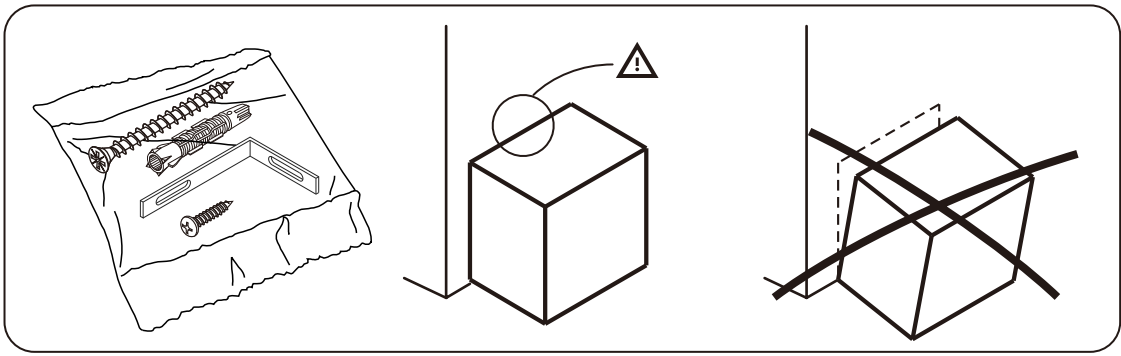

HARDWARE

-BODY SET



#8x35

x 20



M4x16mm.

x 76

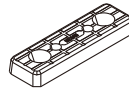

x 8

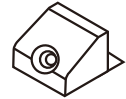

x 3

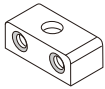

x 4

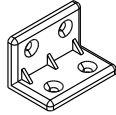

x 15

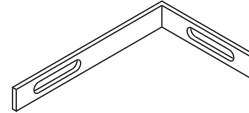

x 1

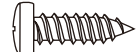

M4x16mm.

x 3

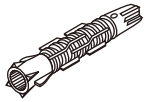

x 1



M5x50mm.

x 1

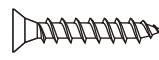

M3.5x20mm.

x 3

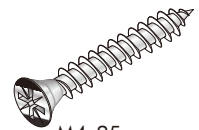

M4x25mm.

x 12

-DRAWER SET

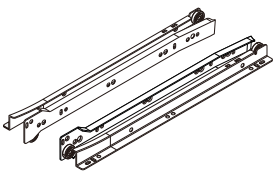

x 2



M3.5x13mm.

x 28

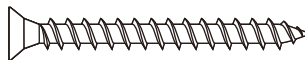

M4x40mm.

x 16



TFL4 M6x23

x 4

ASSEMBLY

-BODY SET

1.

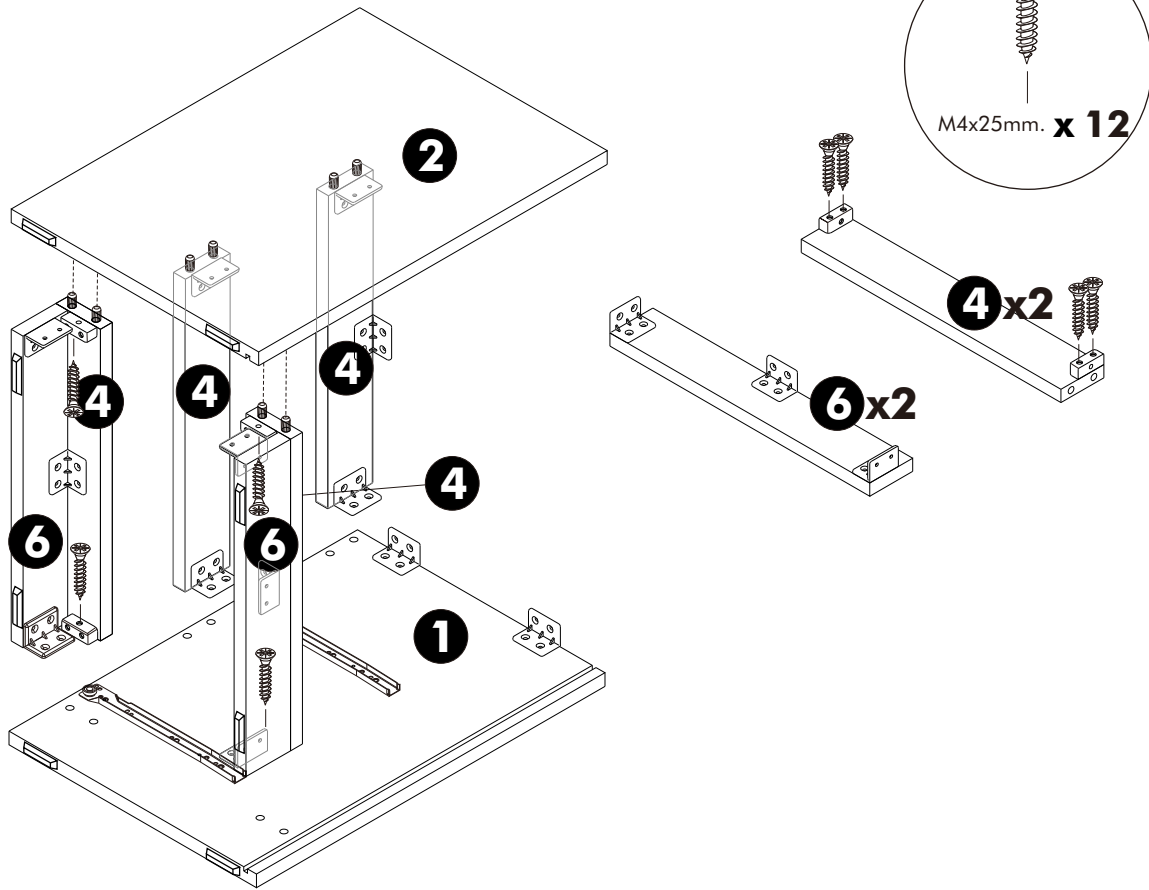

2.

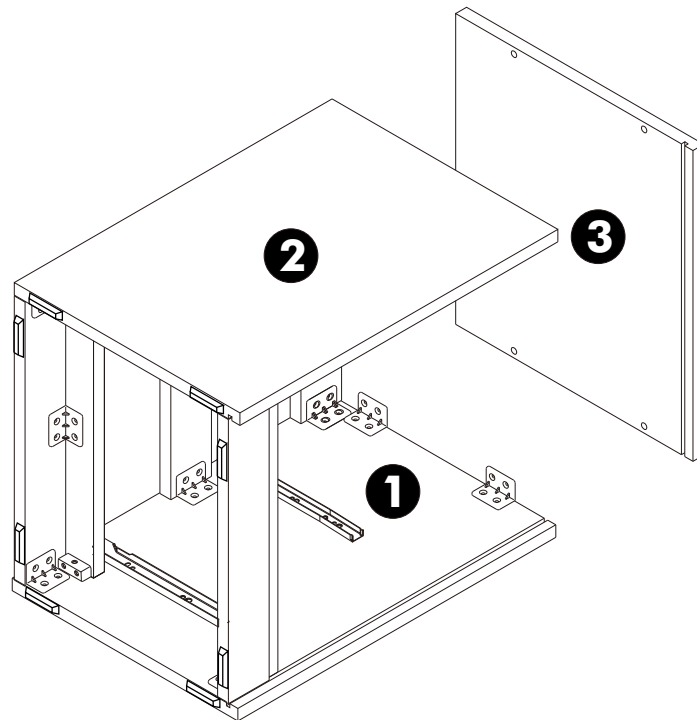

3.

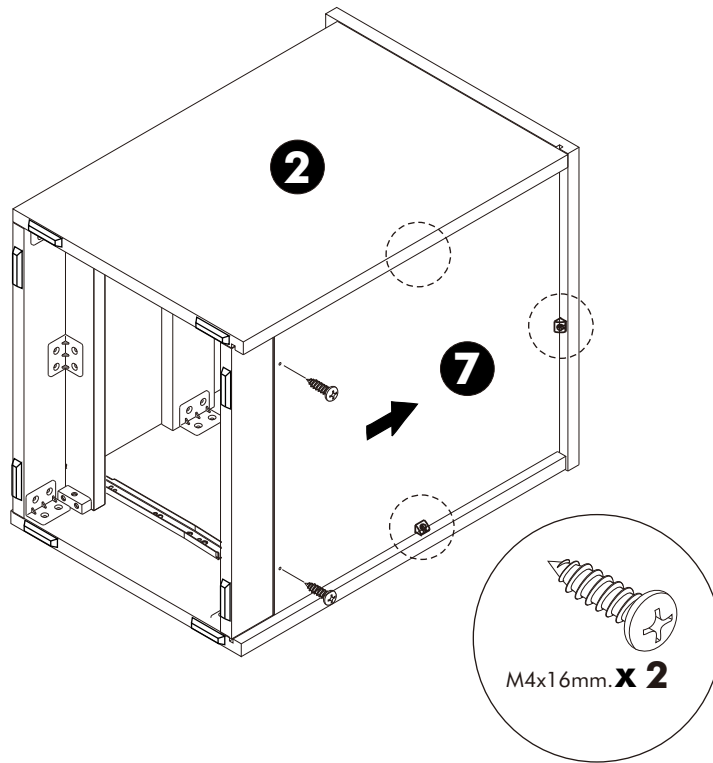

ASSEMBLY

-DRAWER SET

4.

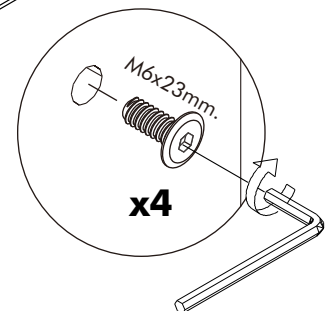
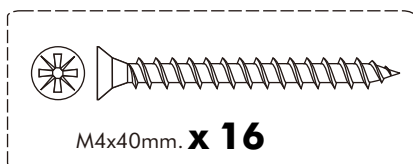
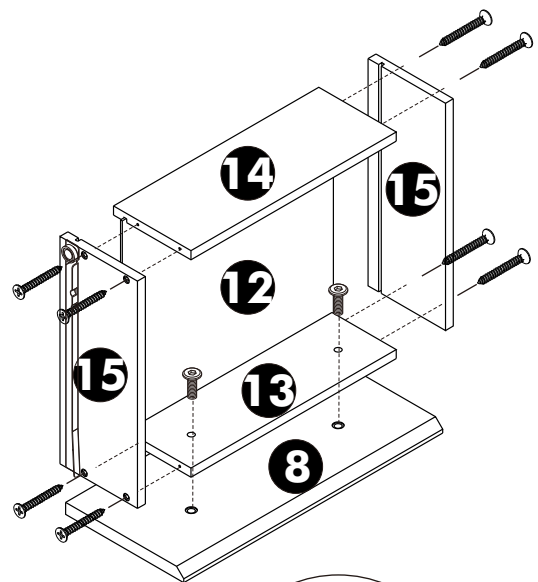
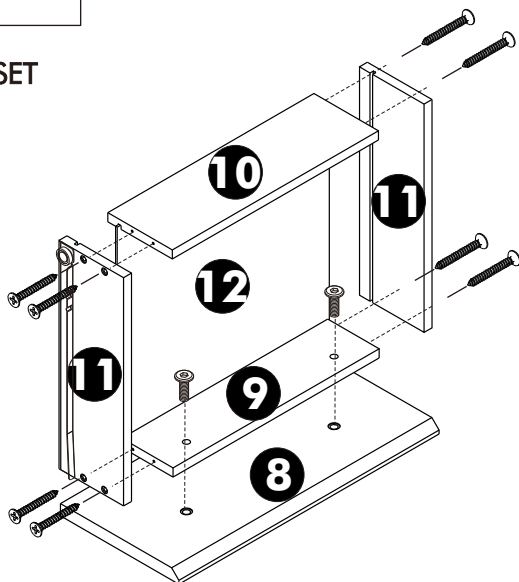

5.

