

# HARSH-P

Wardrobe 5 dr

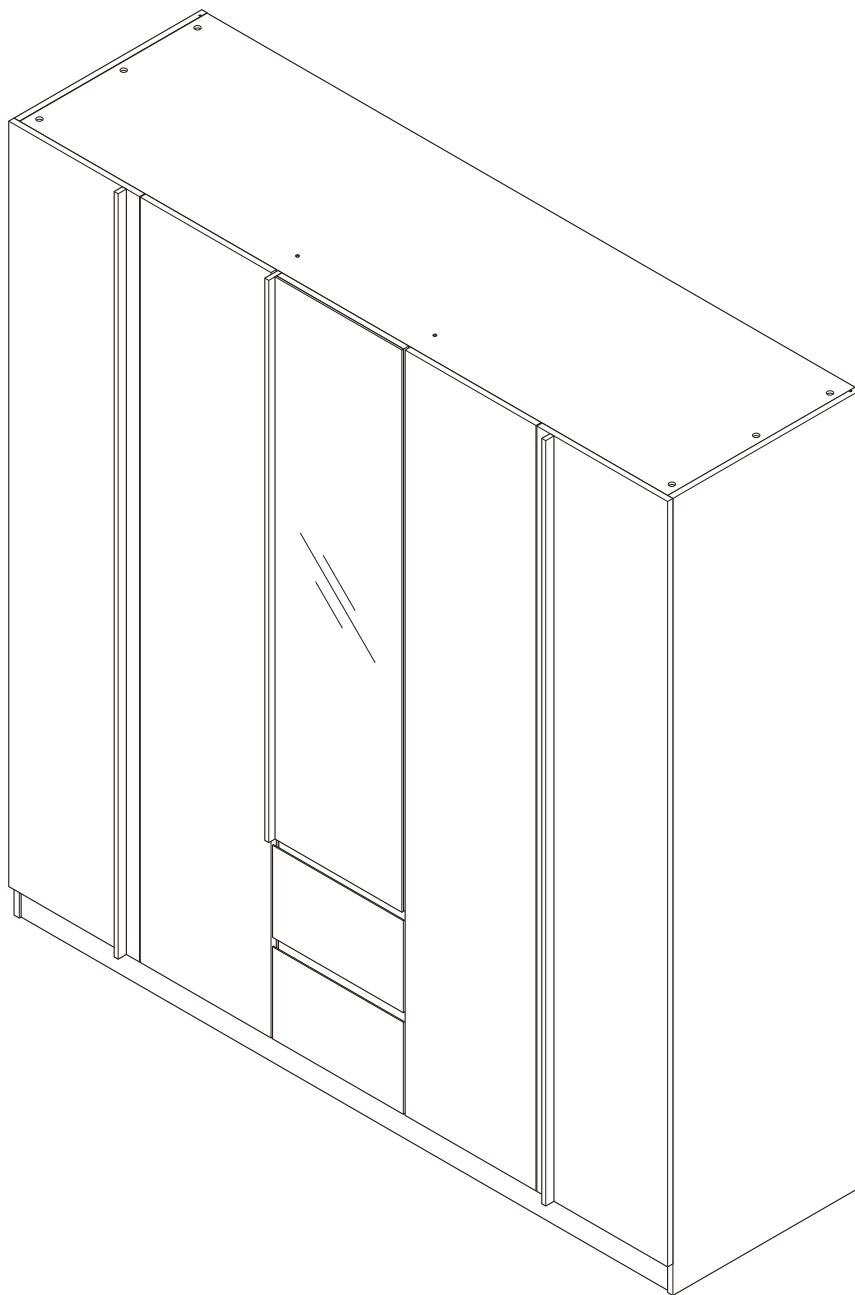

# CONNECT SYSTEM

**1**

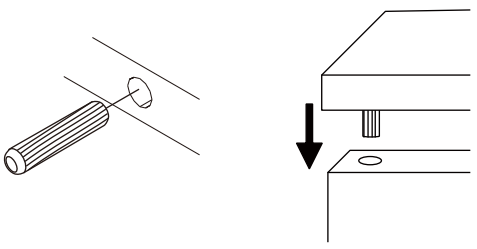

**3**

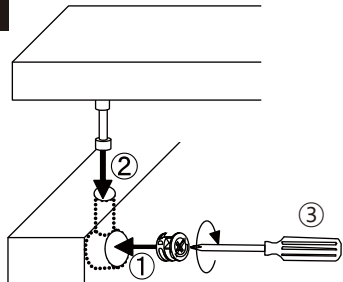

**2**

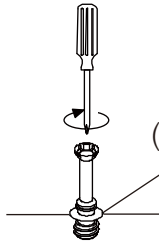

(Connecting bolts)

WHEN FITTING CAMS  
ENSURE STARTING POSITION IS CORRECT  
BEFORE YOU INSERT CONNECTING BOLT  
TURN CLOCKWISE UNTIL SECURE



↑  
CORRECT



WRONG

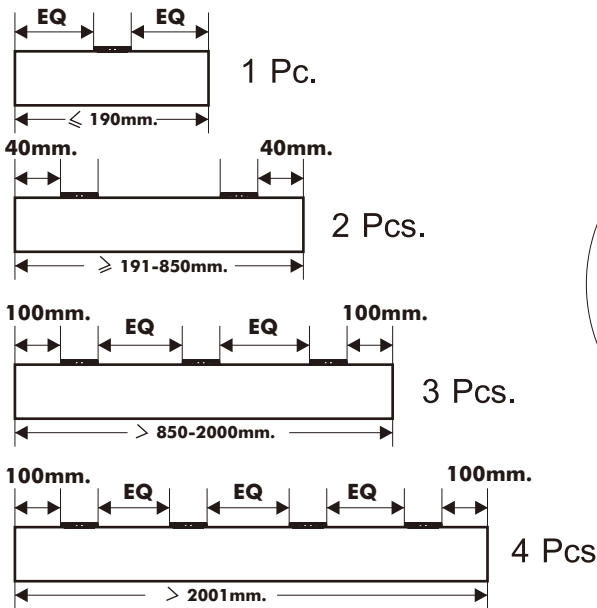

**i**

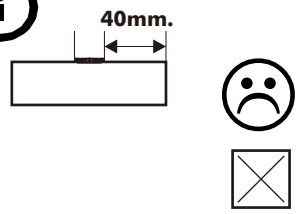
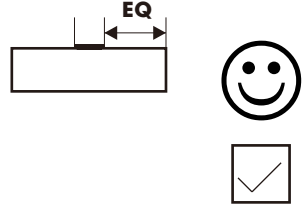

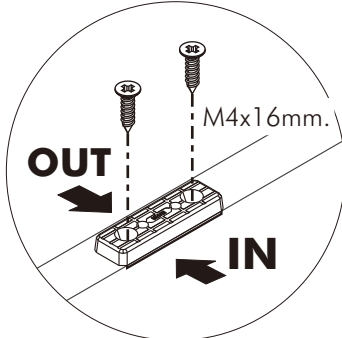

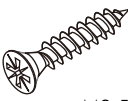

M4x16mm.

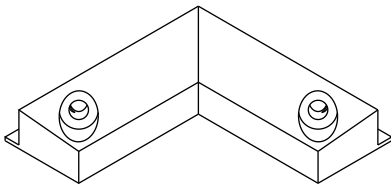

M3.5x20mm.



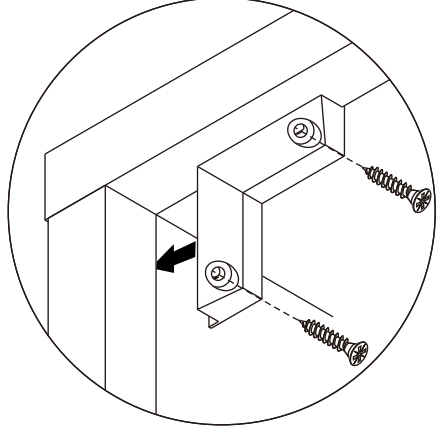

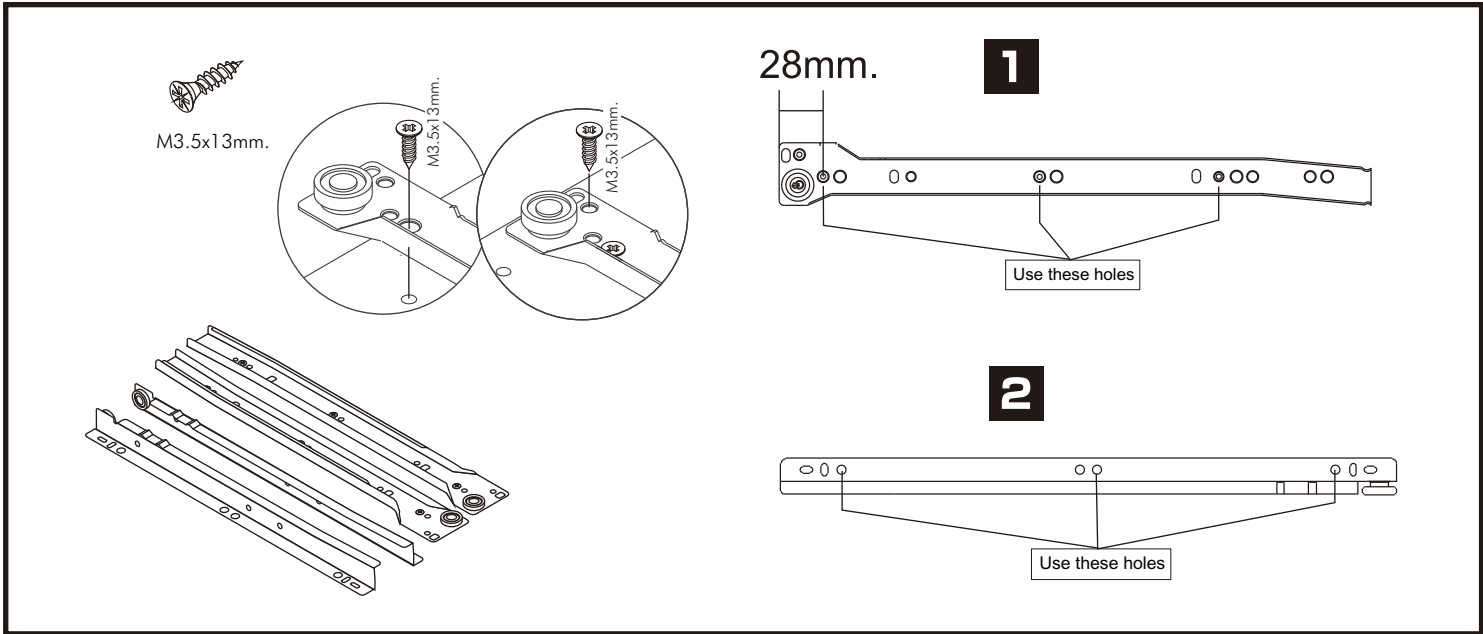
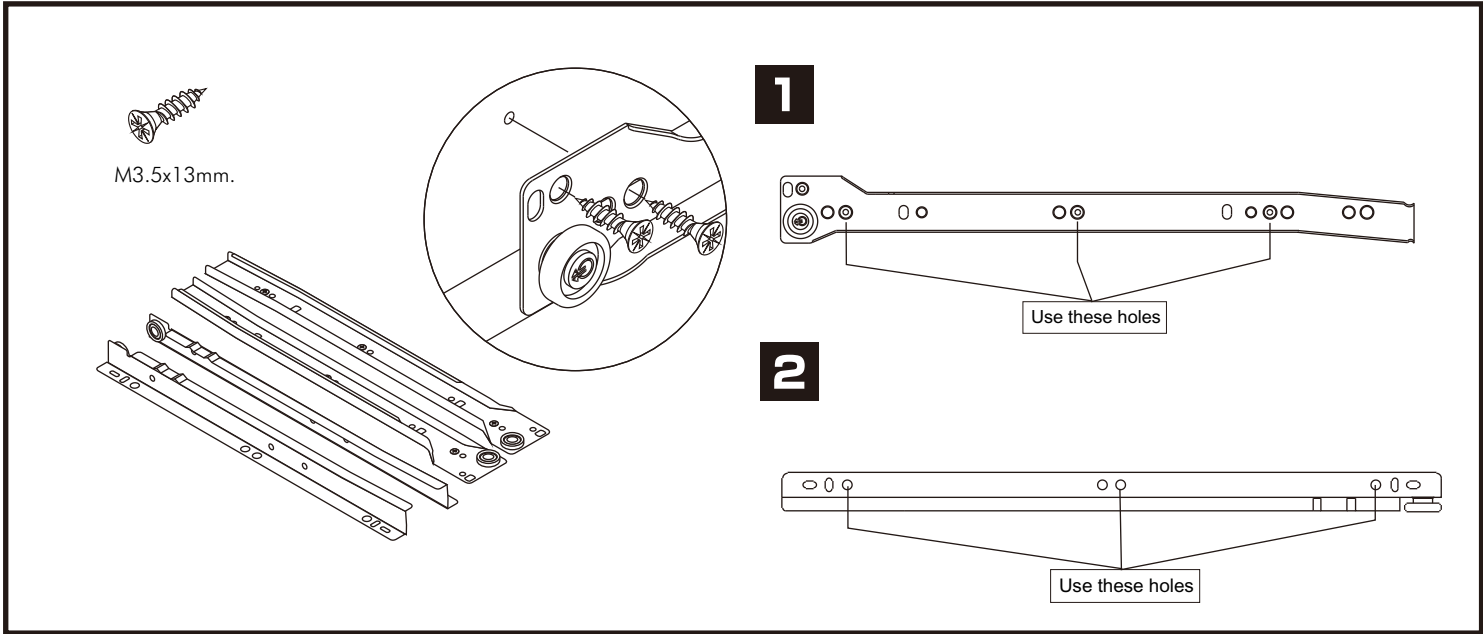

**x2**

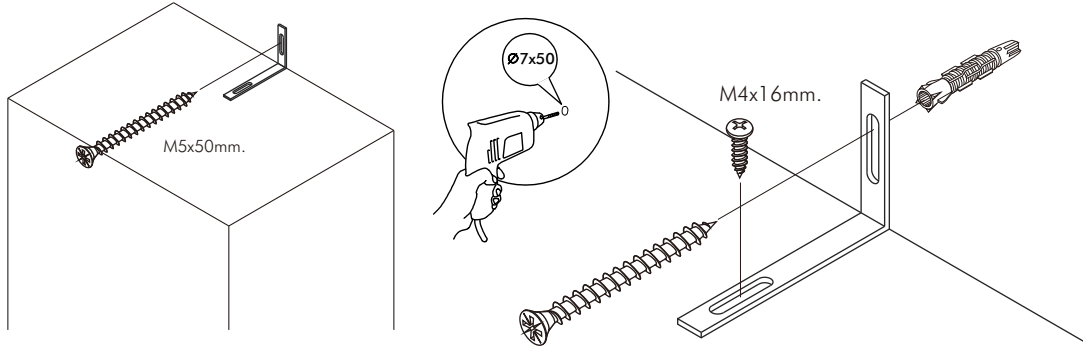

**The Standard for identifying which mounted safety fall protection fitting to use** **Note : That children's products must be installed with all anti-falling fittings.**

■ Mounted fall protection fittings



■ Category : Cabinet with open doors



■ Category : Chest of drawers



■ Category : Sliding door cabinet / Open cabinet



# HARDWARE

## -BODY SET

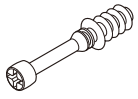

**x 36**



#19mm.

**x 32**

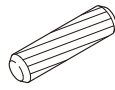

#8x35

**x 66**

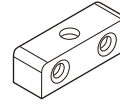

**x 8**

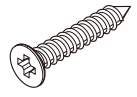

#M4x25(F)

**x 48**

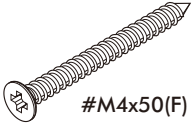

#M4x50(F)

**x 8**



#M4x40(F)

**x 18**



**x 4**

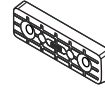

**x 16**

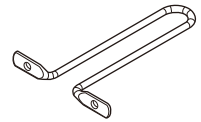

**x 1**



#M4x16(P)

**x 43**

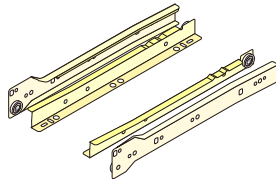

**x 2 SET**



#M3.5x13(F)

**x 36**

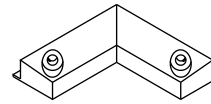

**x 2**

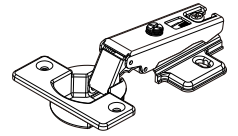

**x 16**



#M4x16(F)

**x 108**



M3.5x20mm.

**x 4**



**x 10**

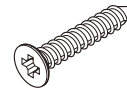

#M4x30(F)

**x 12**



Ø11mm.

**x 12**

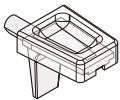

**x 4**



#TFL4 M6x23

**x 8**

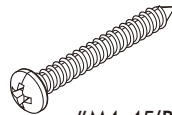

#M4x45(P)

**x 6**

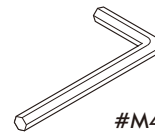

#M4

**x 1**

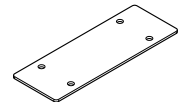

**x 2**



#16mm.

**x 4**



**x 4**

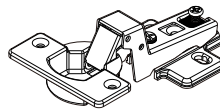

**x 3**



**x 2**

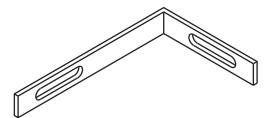

**x 2**

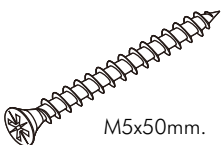

M5x50mm.

**x 2**

# ASSEMBLY

-BODY SET

**1.**

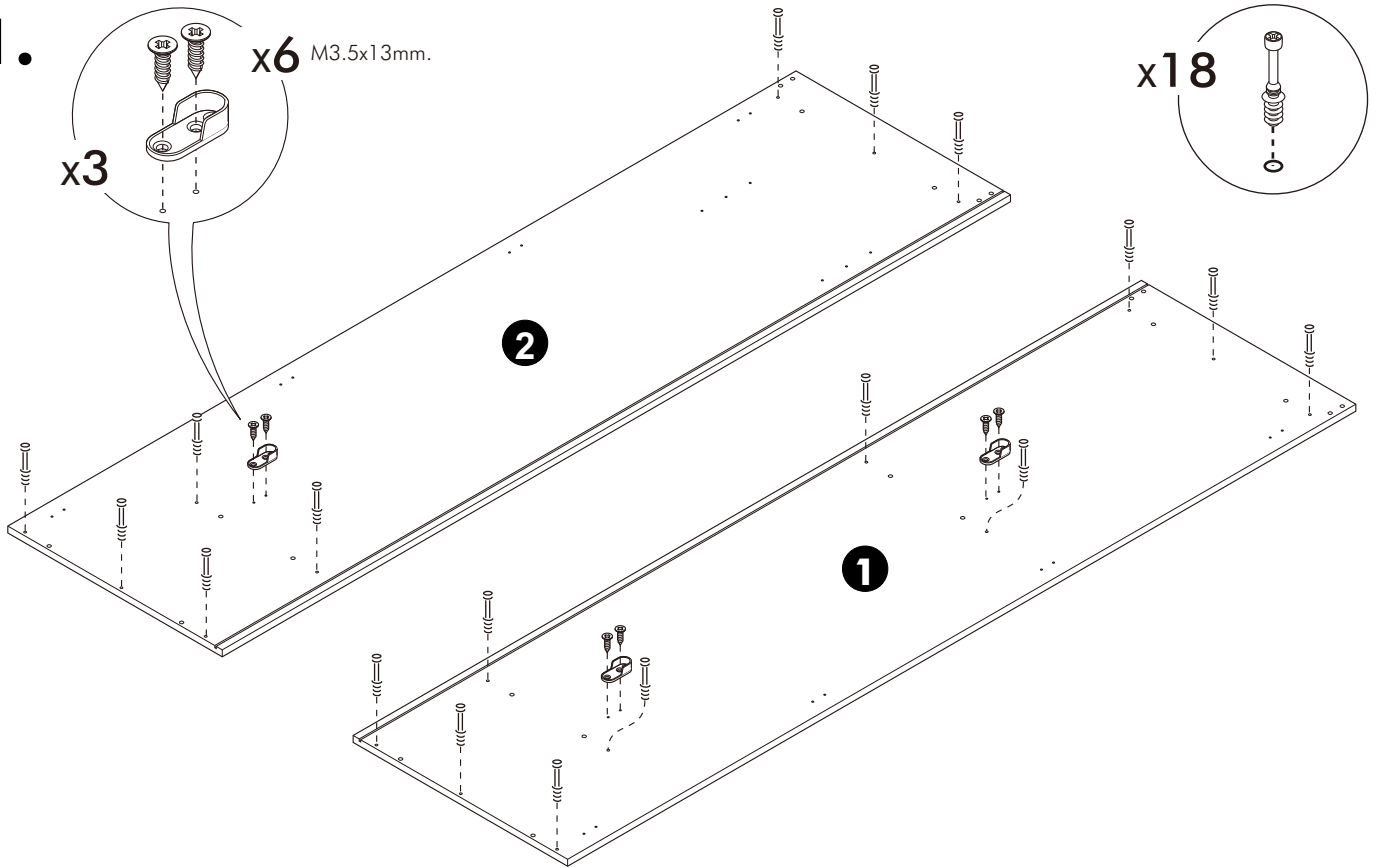

**2.**

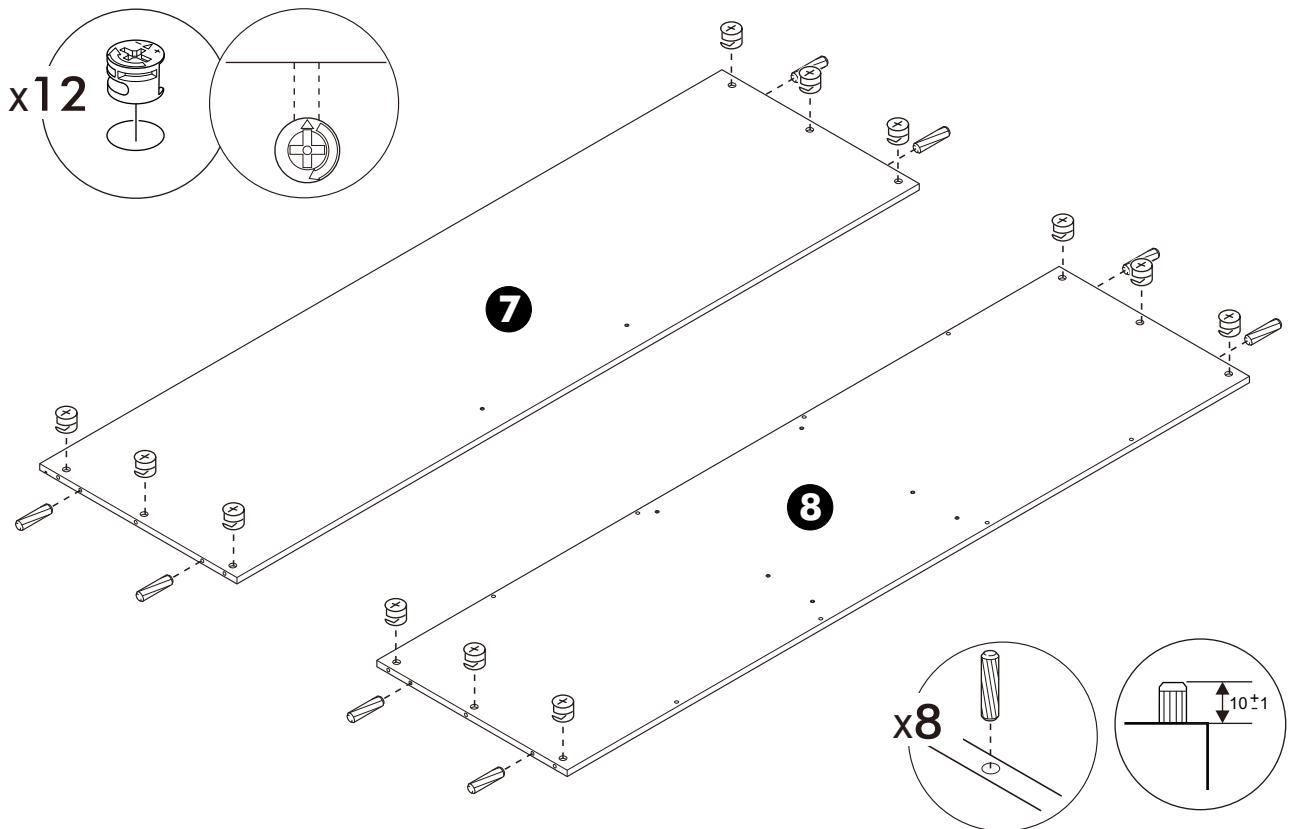

**3.**

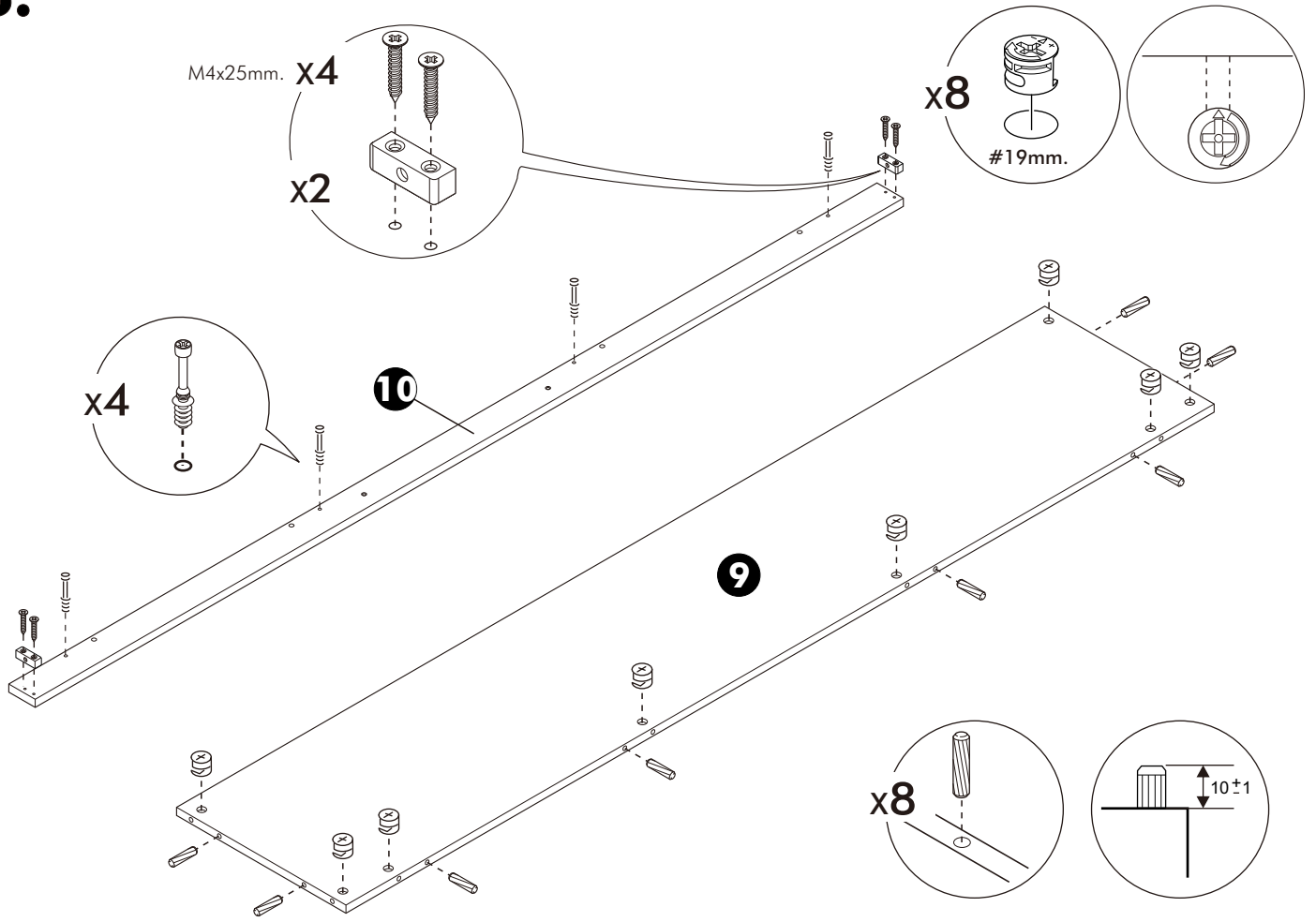

**4.**

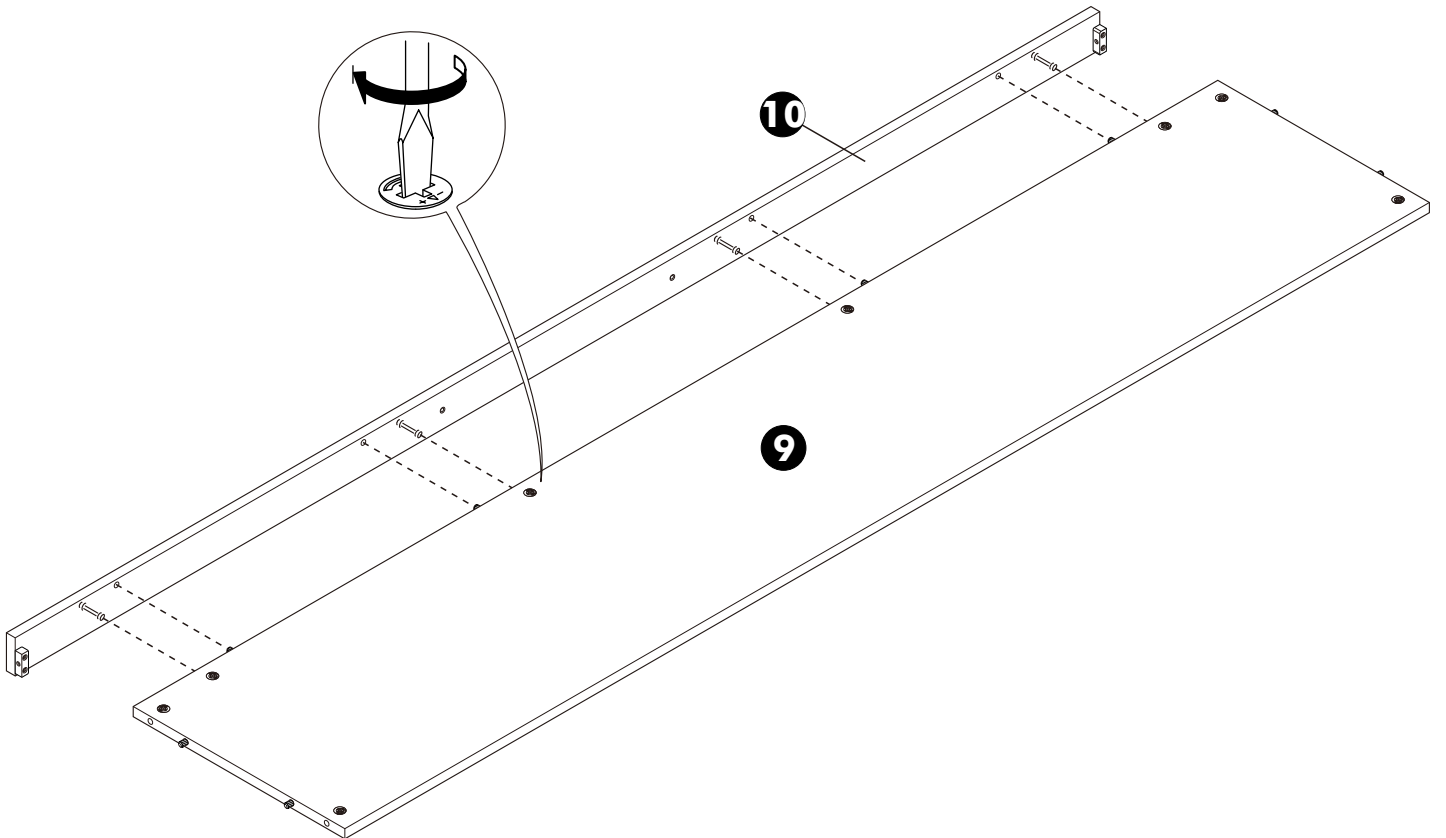

5.

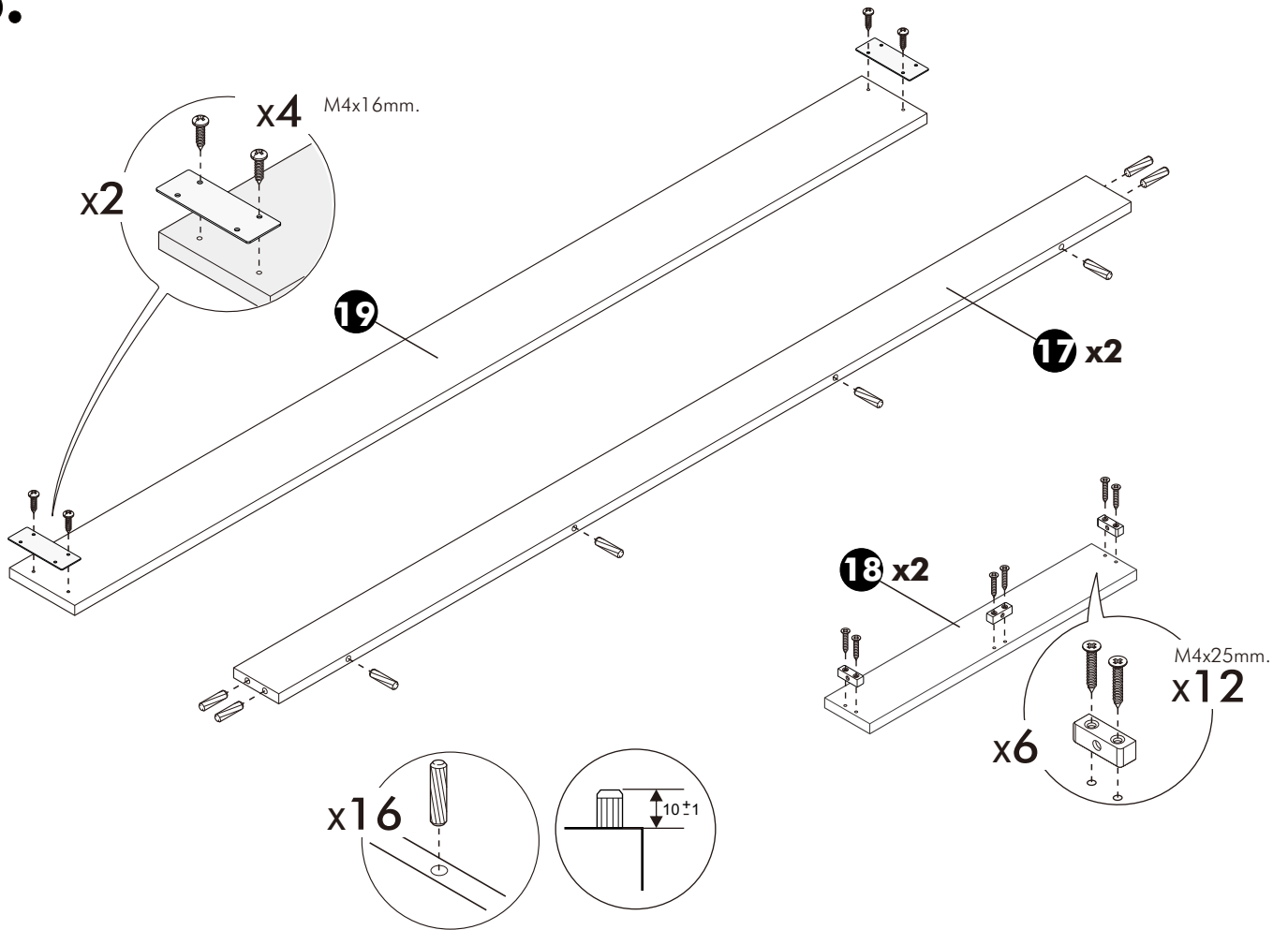

6.

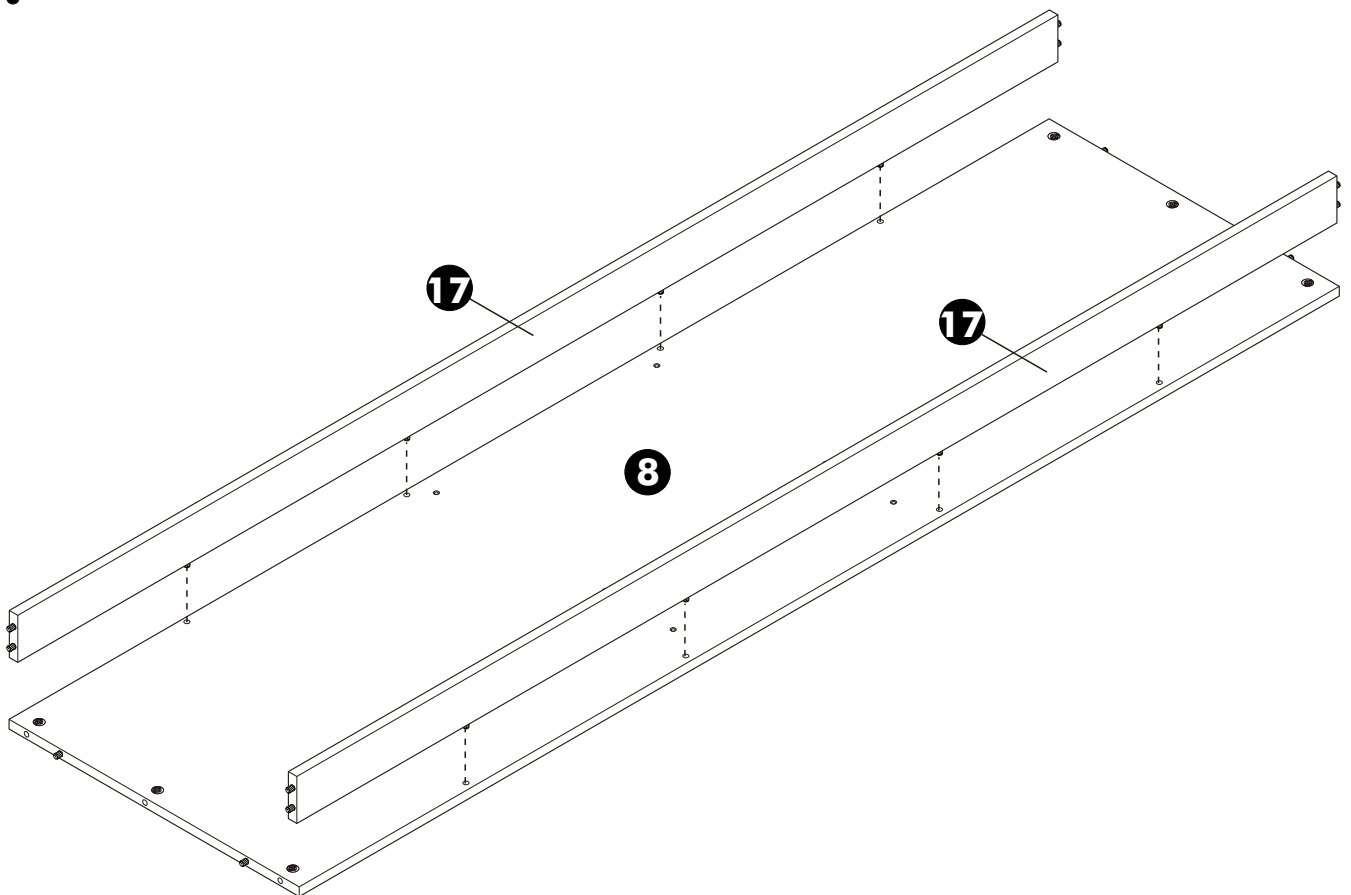

**7.**

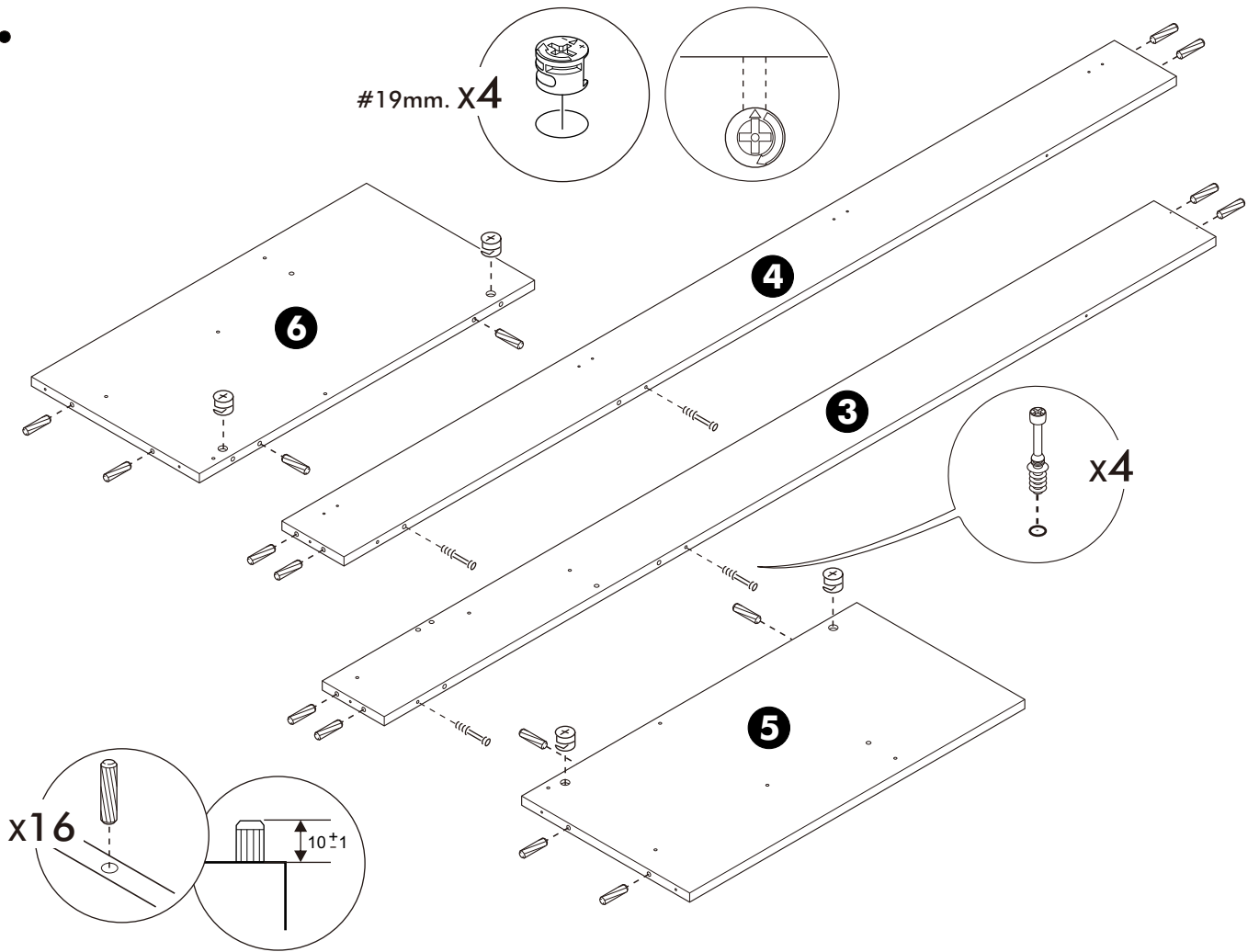

**8.**

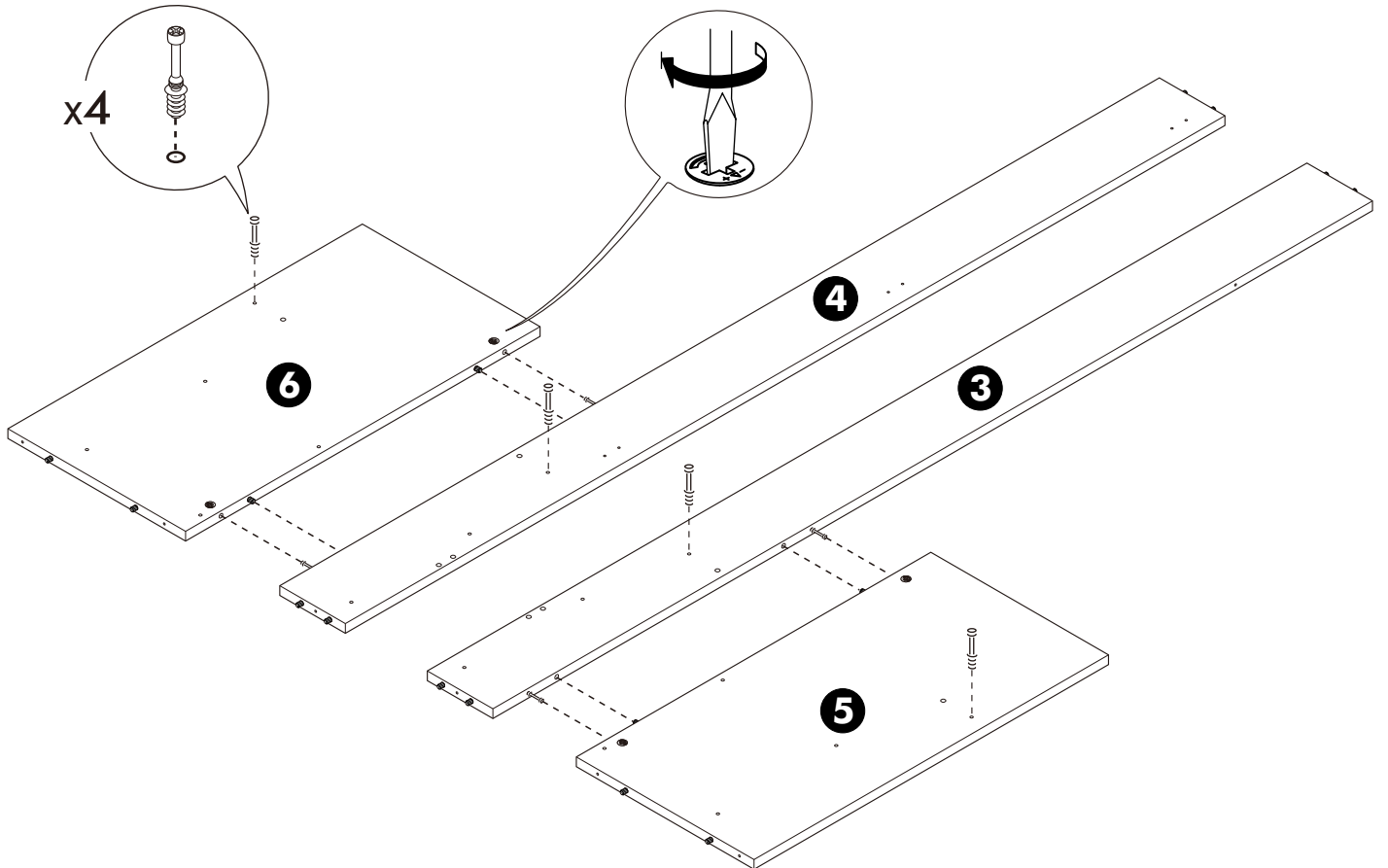

9.

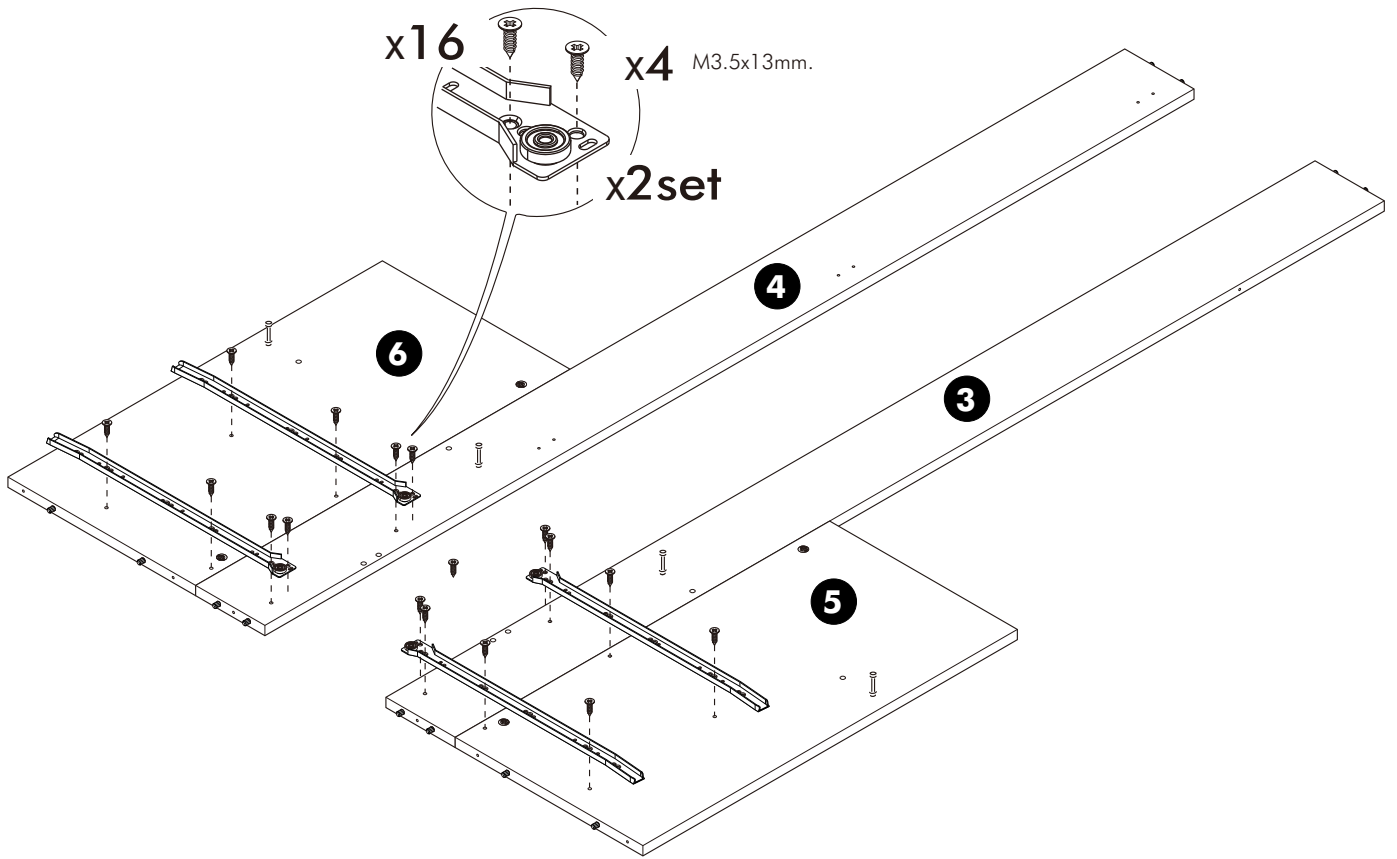

10.

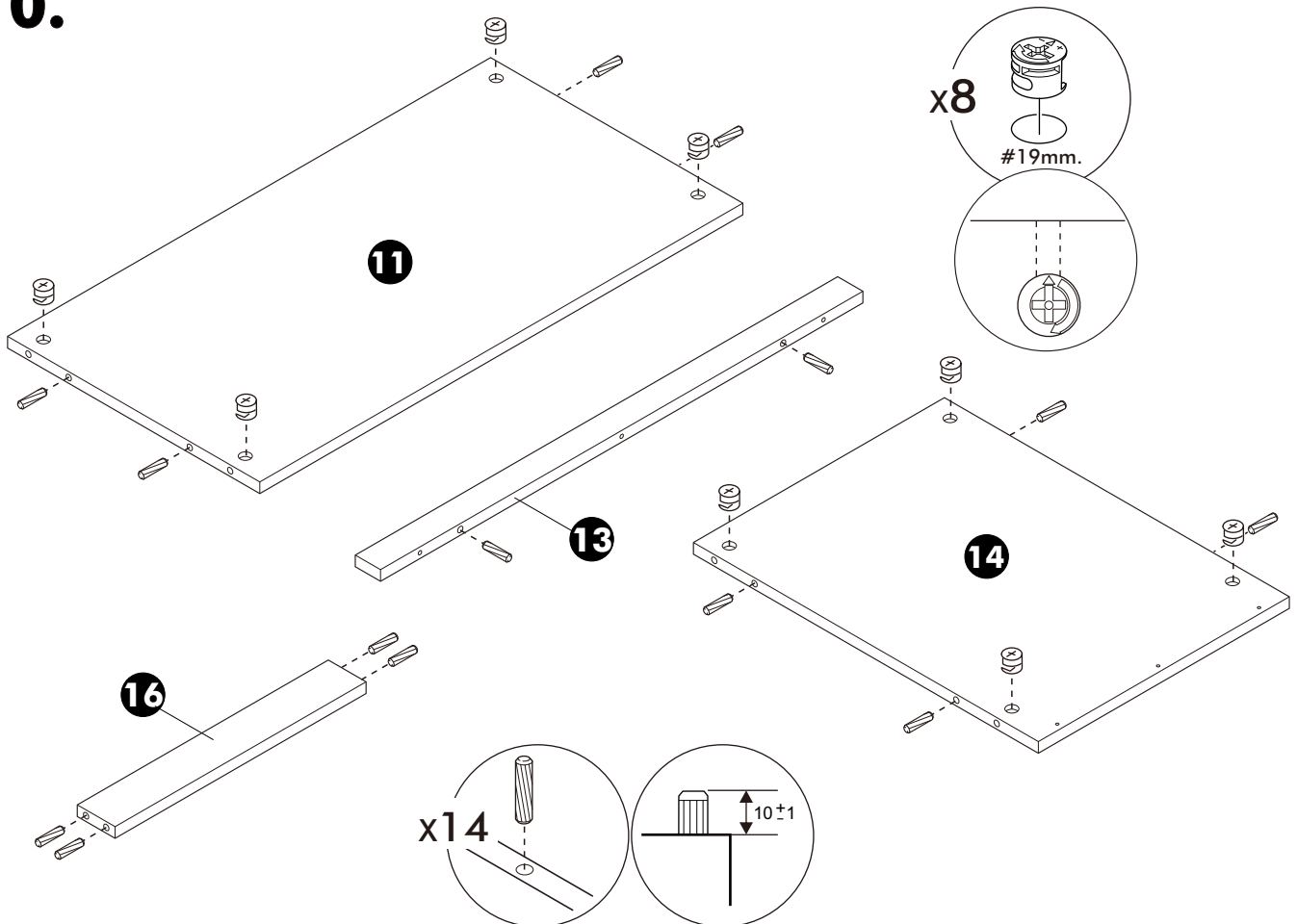

# 11.

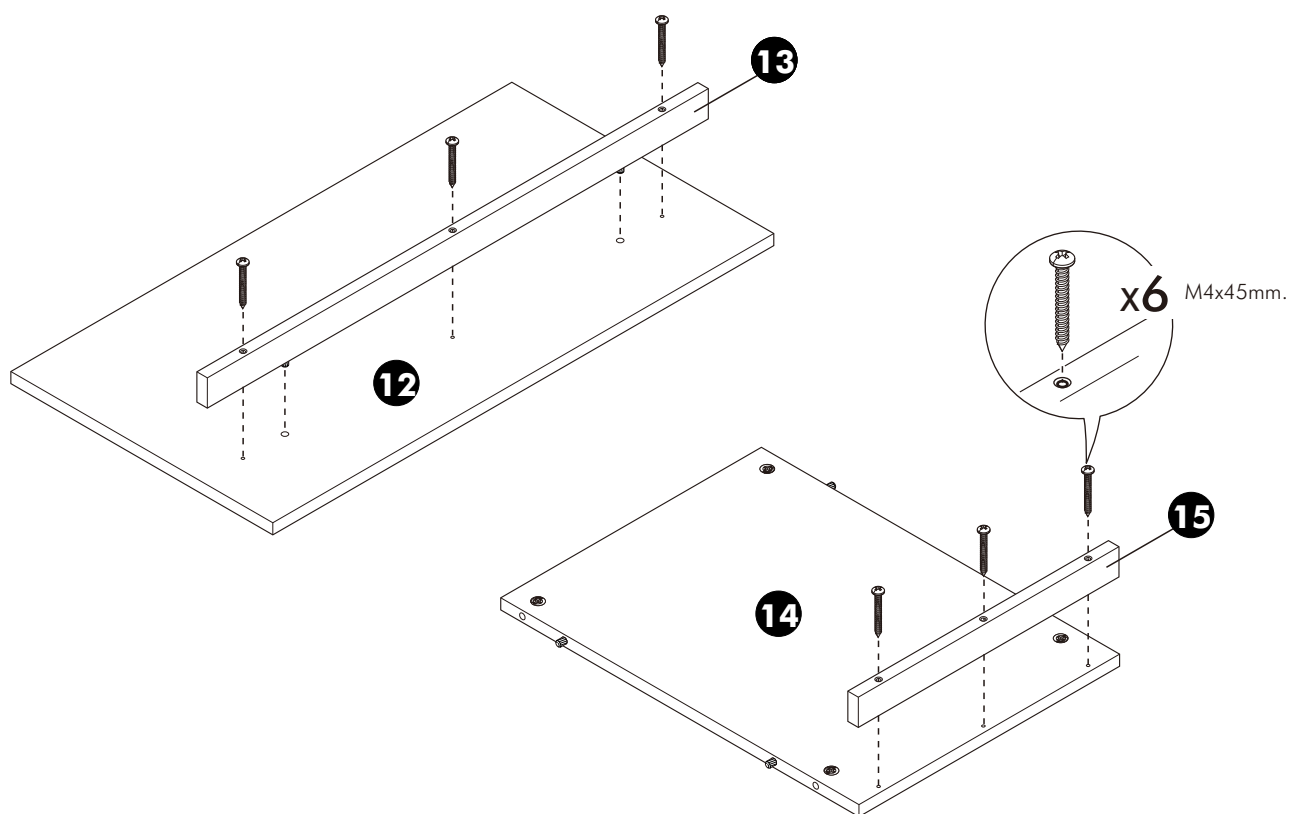

# 12.

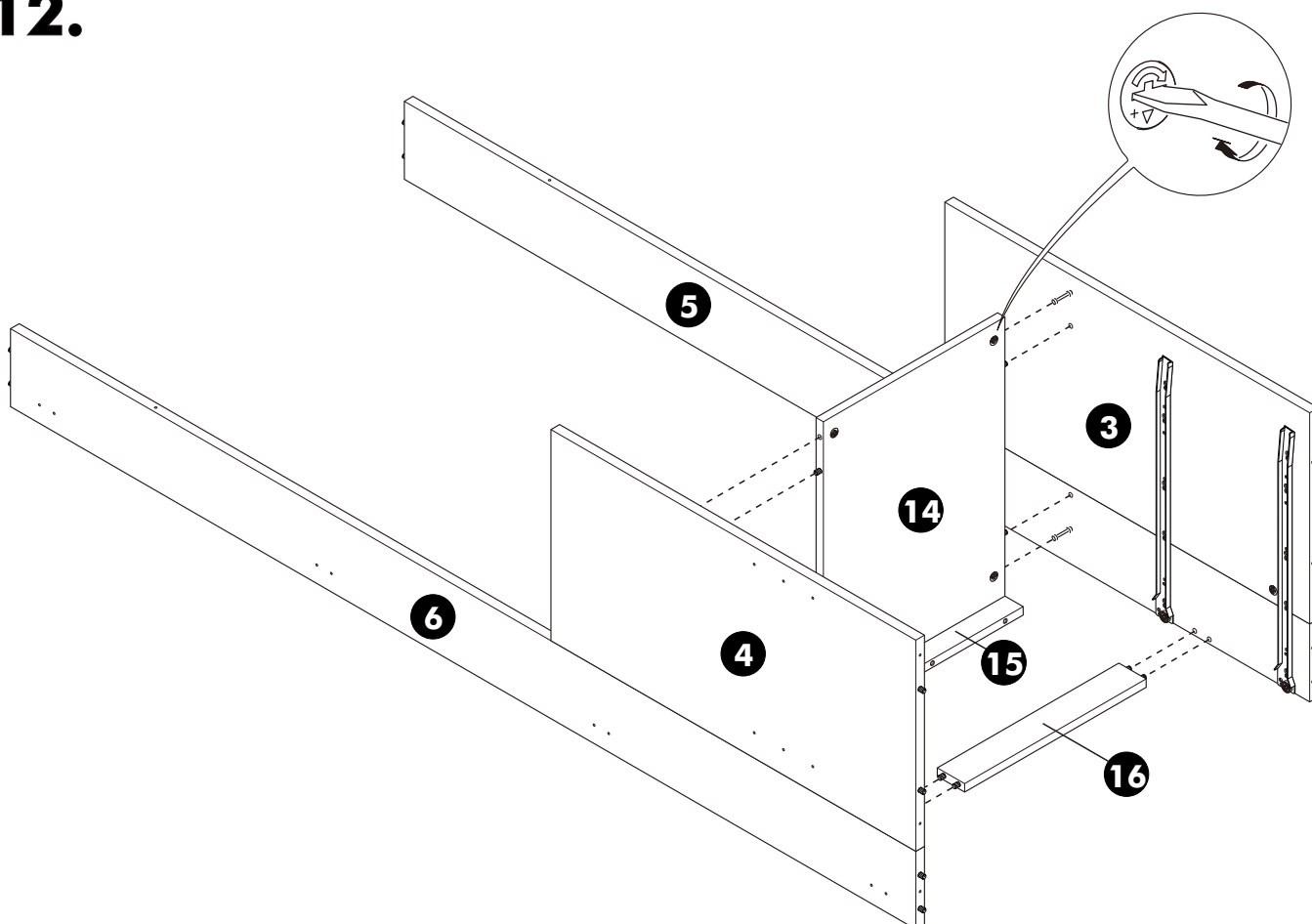

**13.**

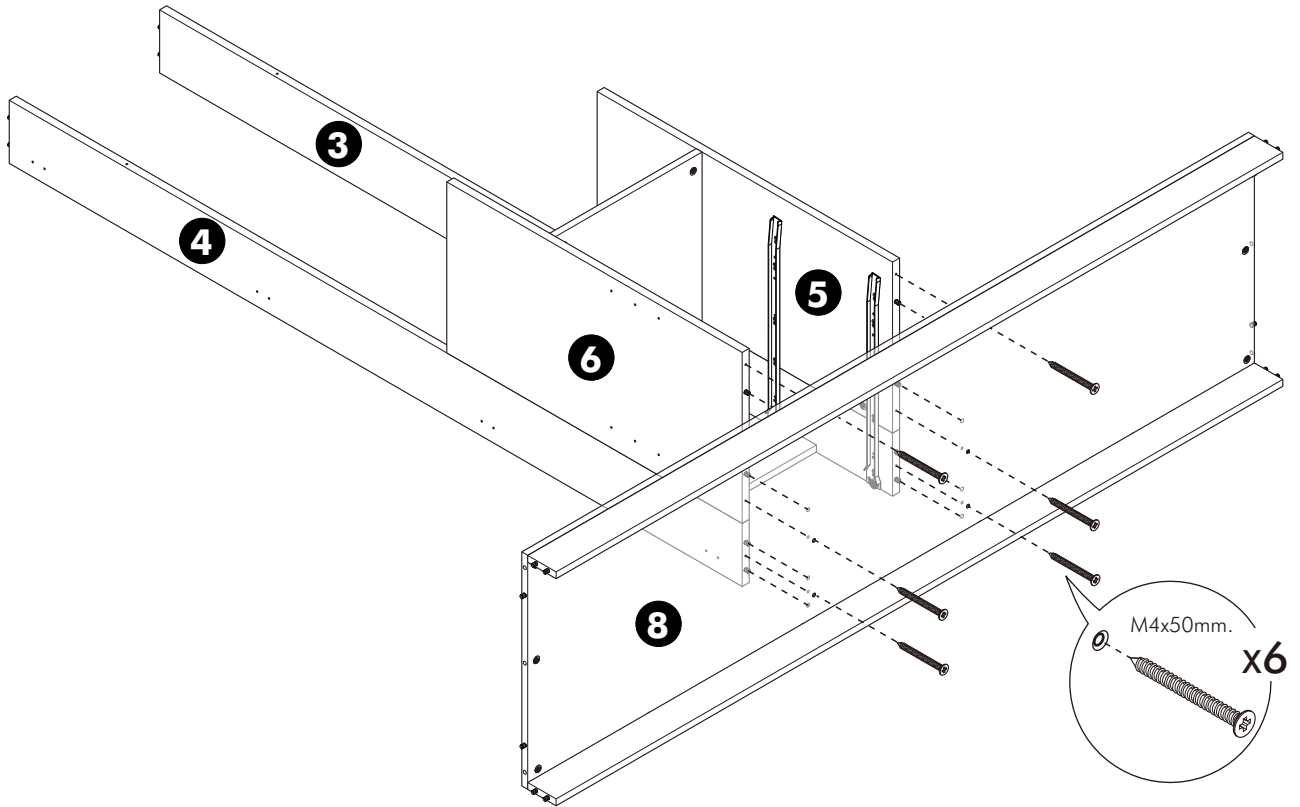

**14.**

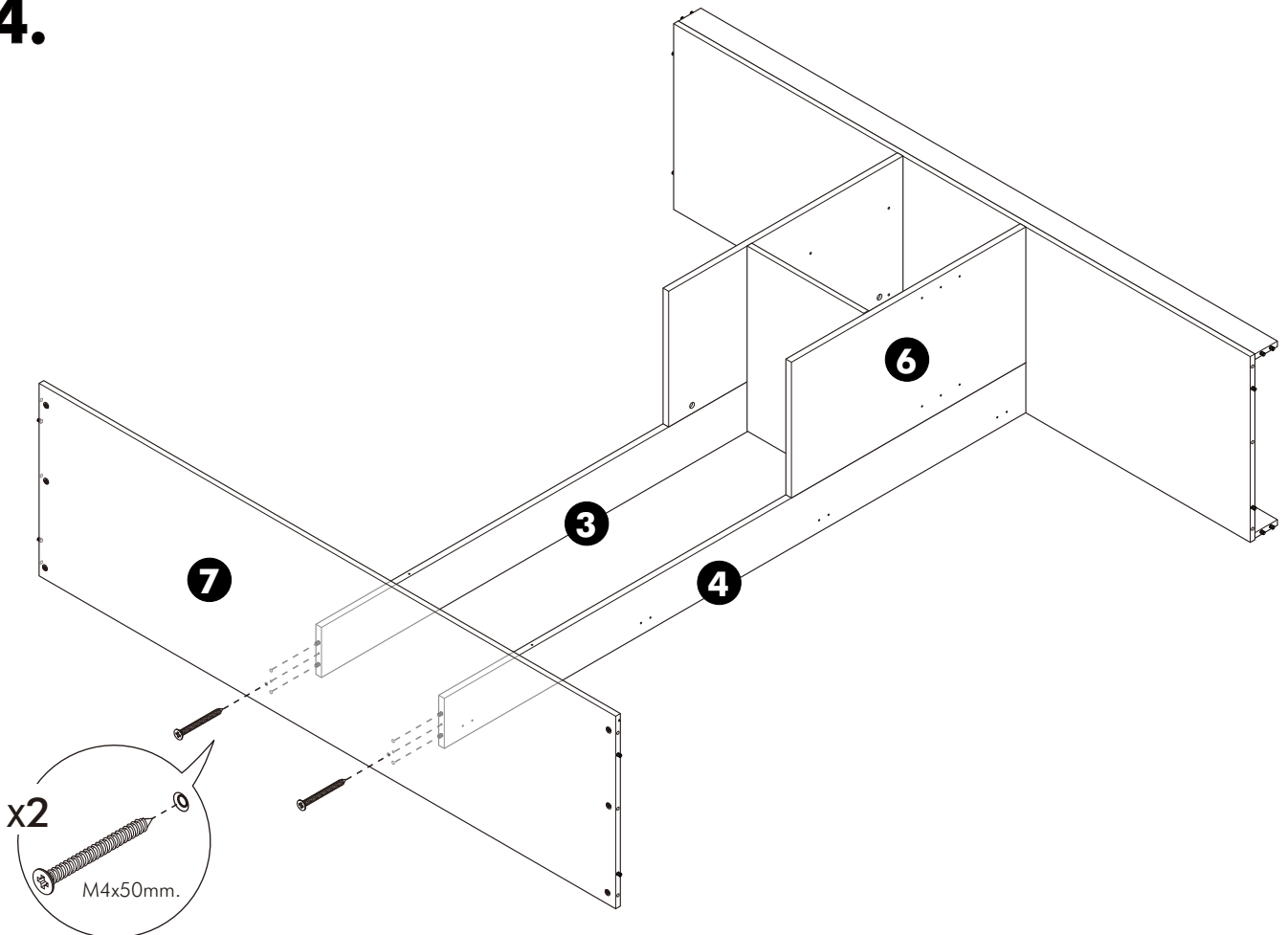

**15.**

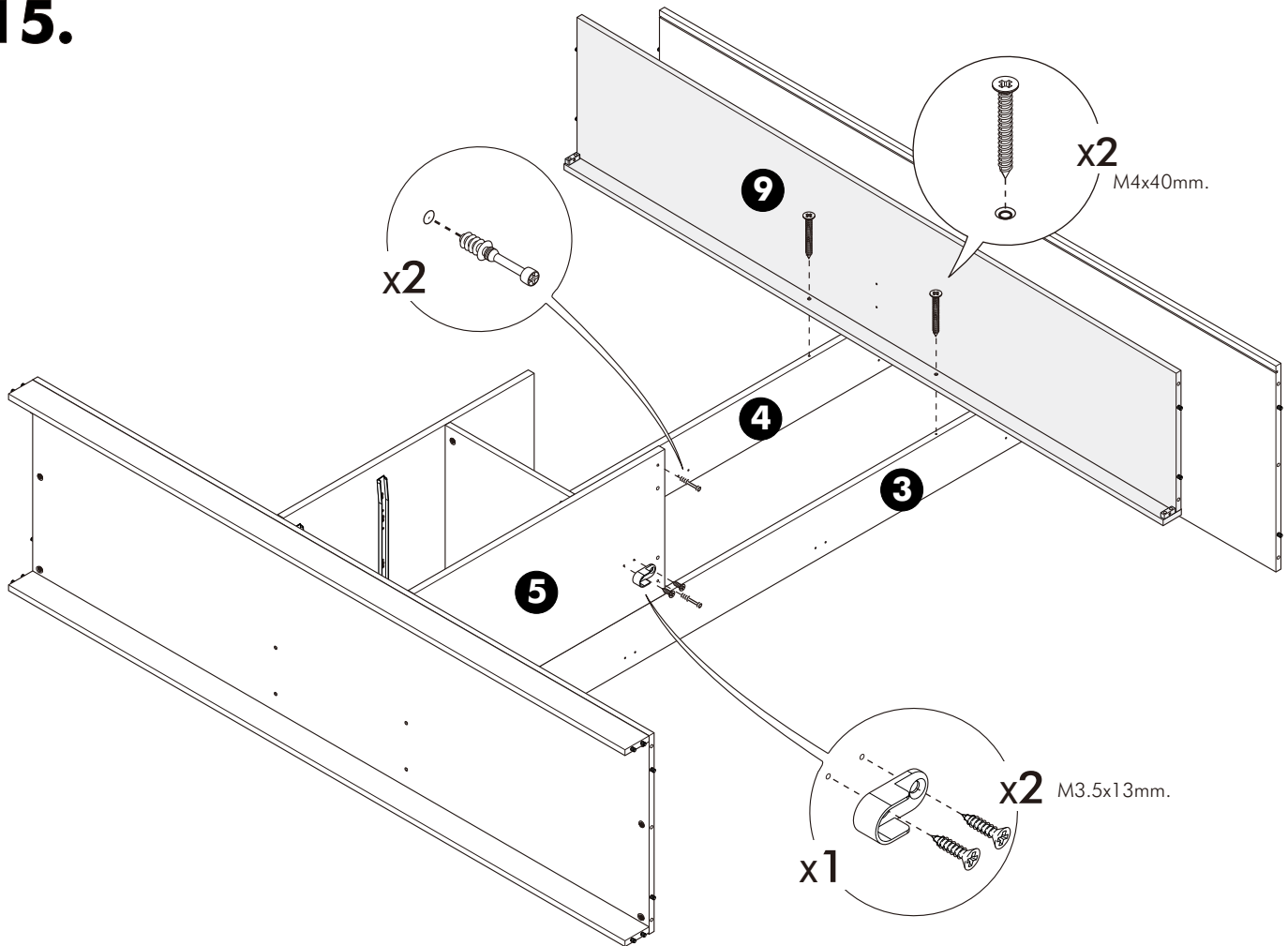

**16.**

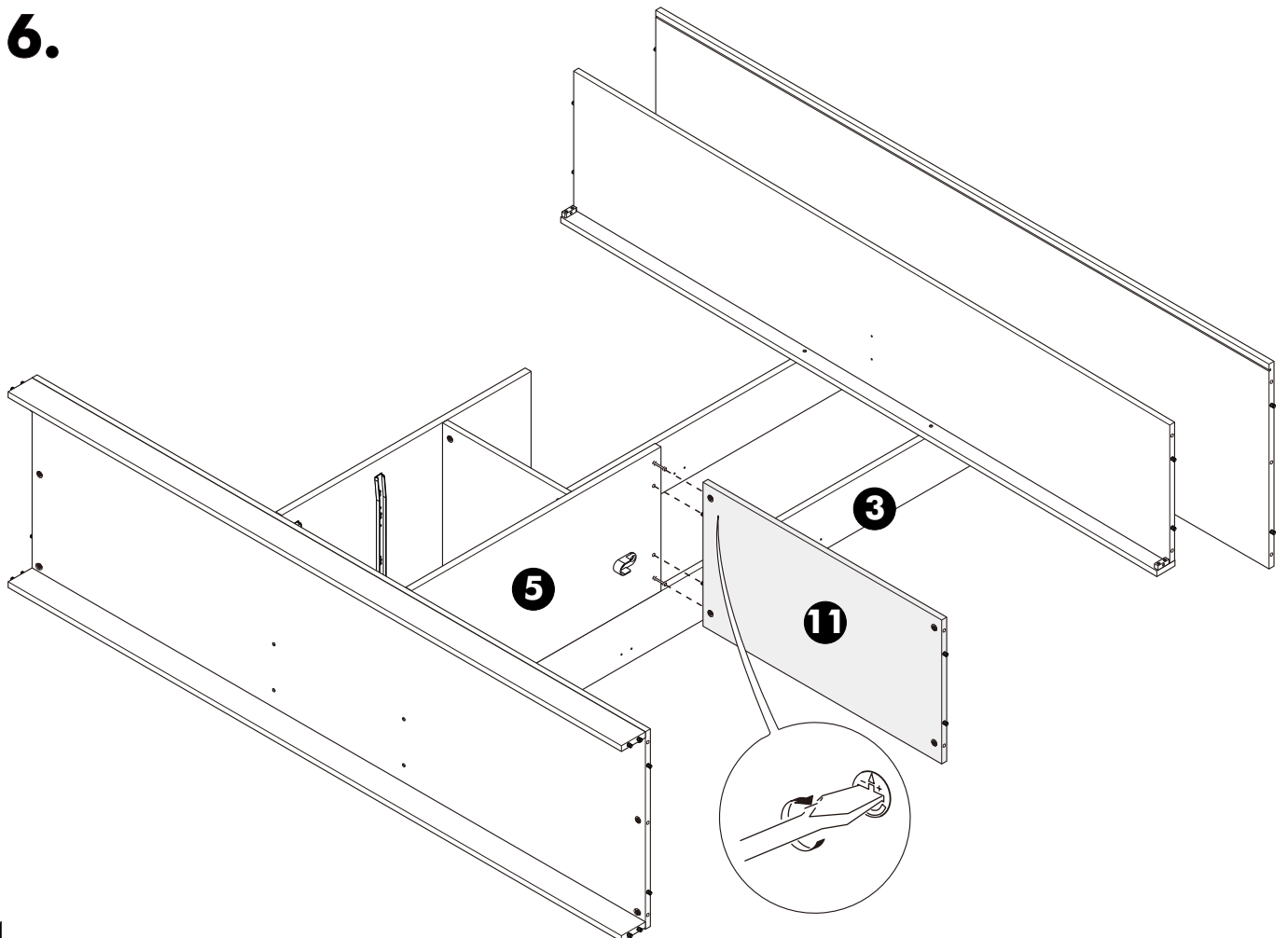

**17.**

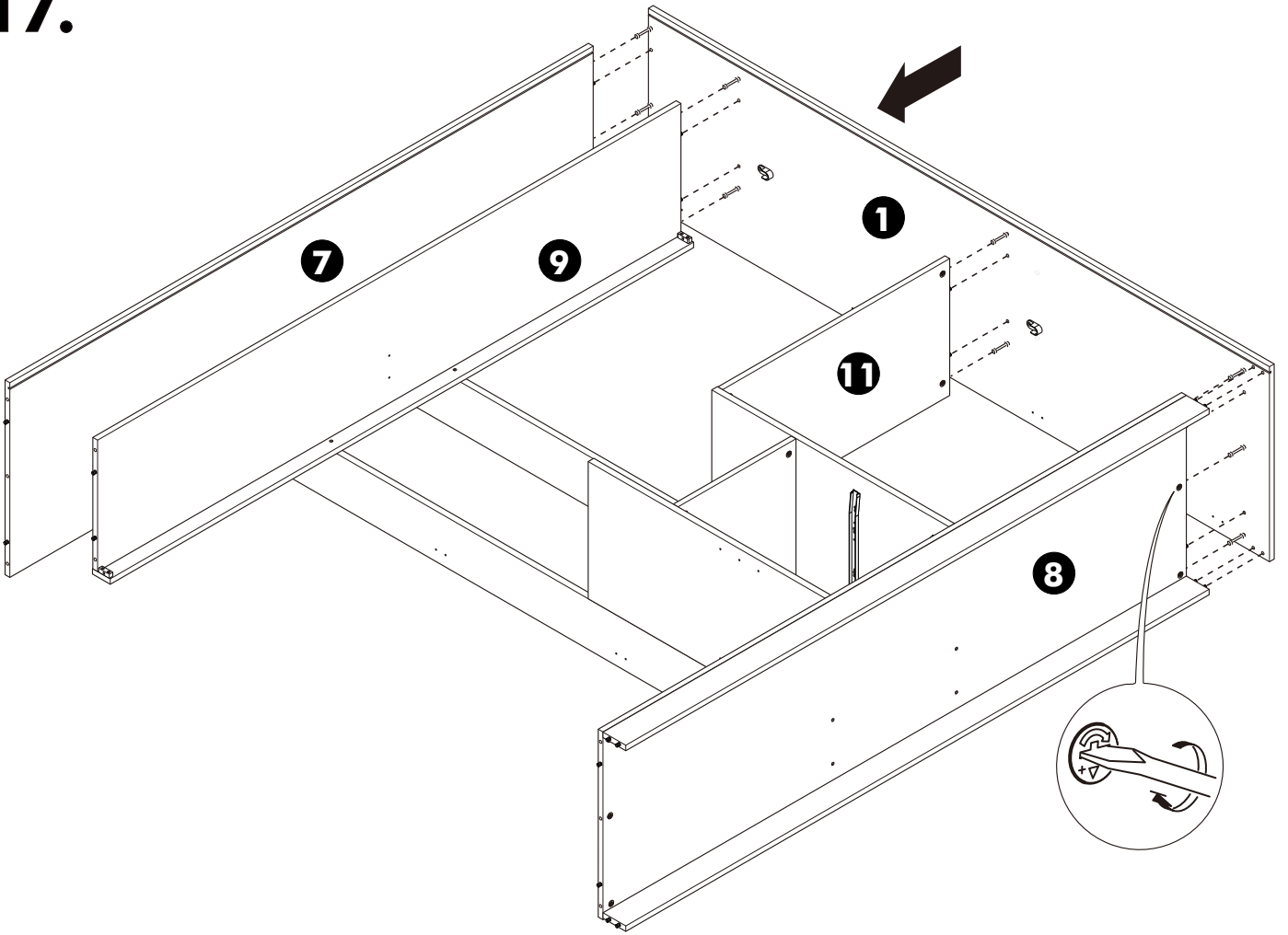

**18.**

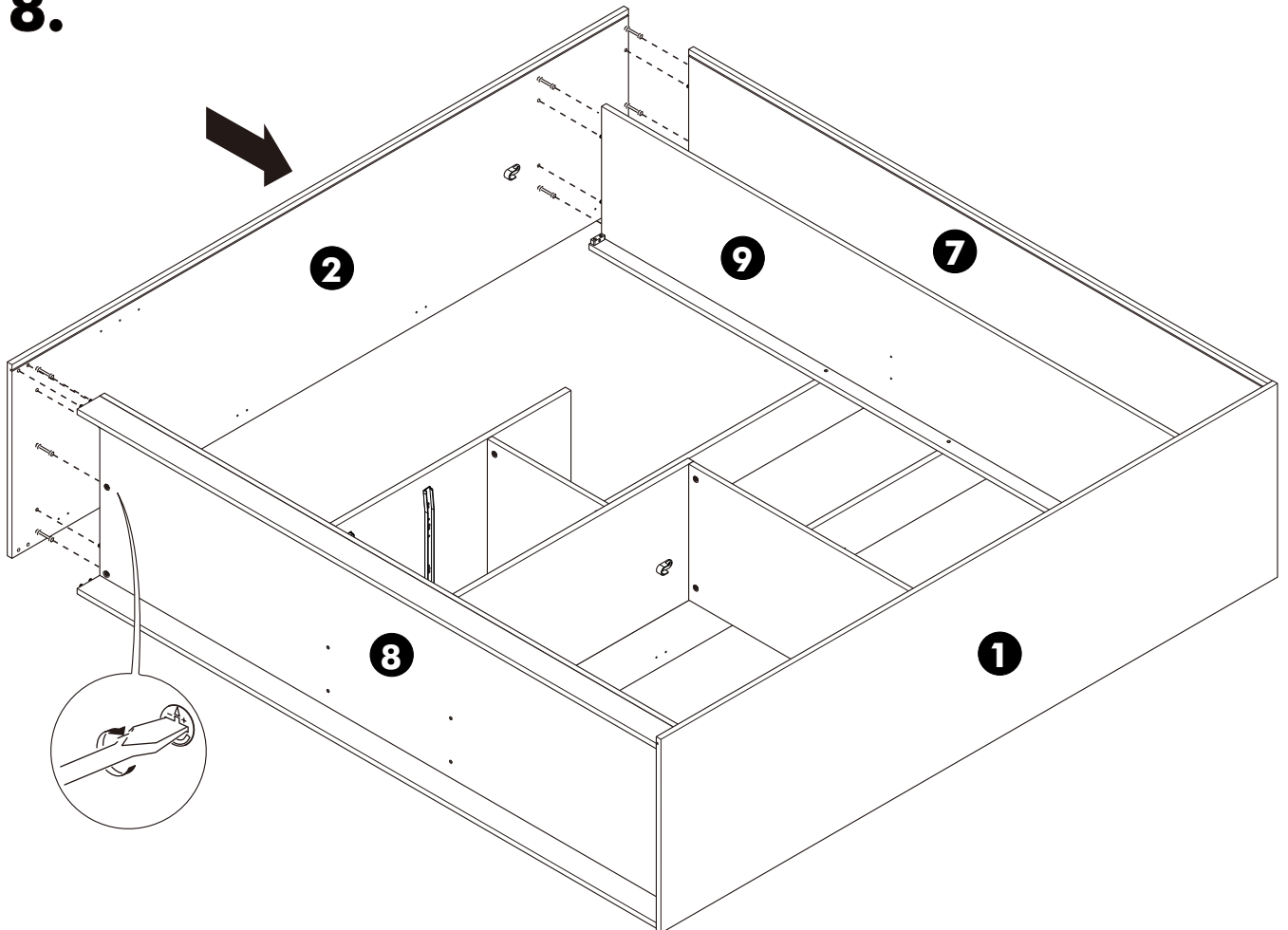

# 19.

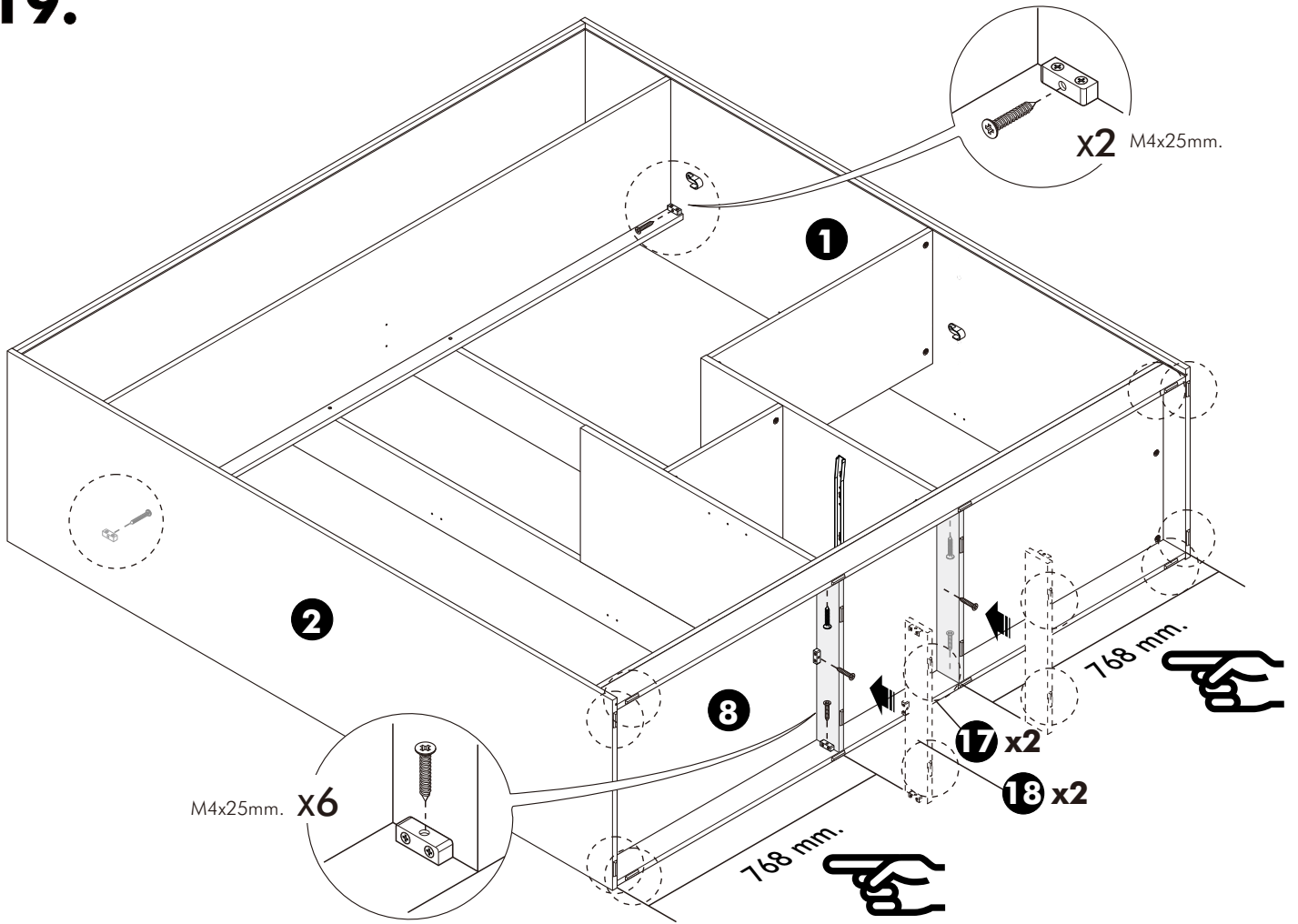

# 20.

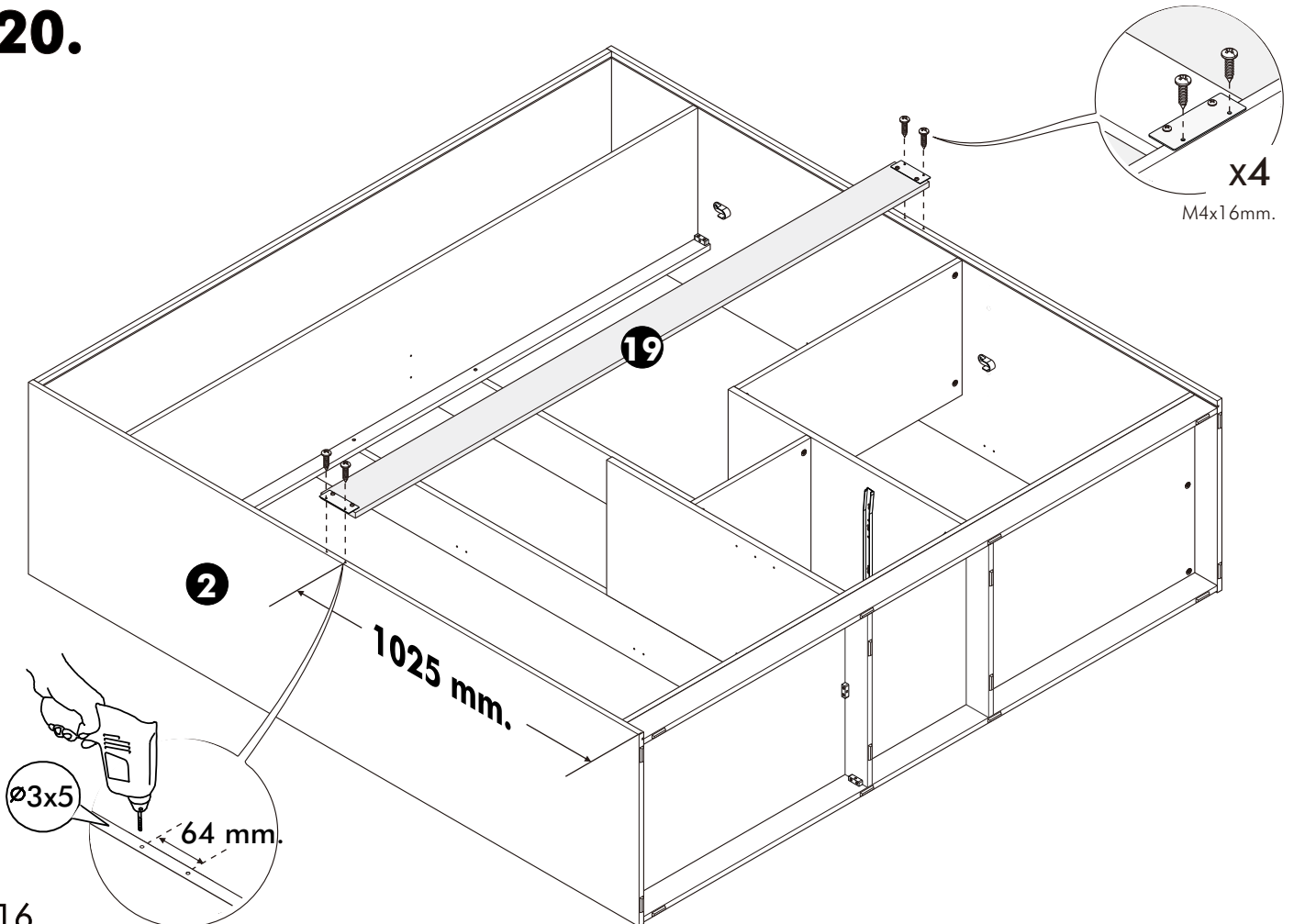



**23.**

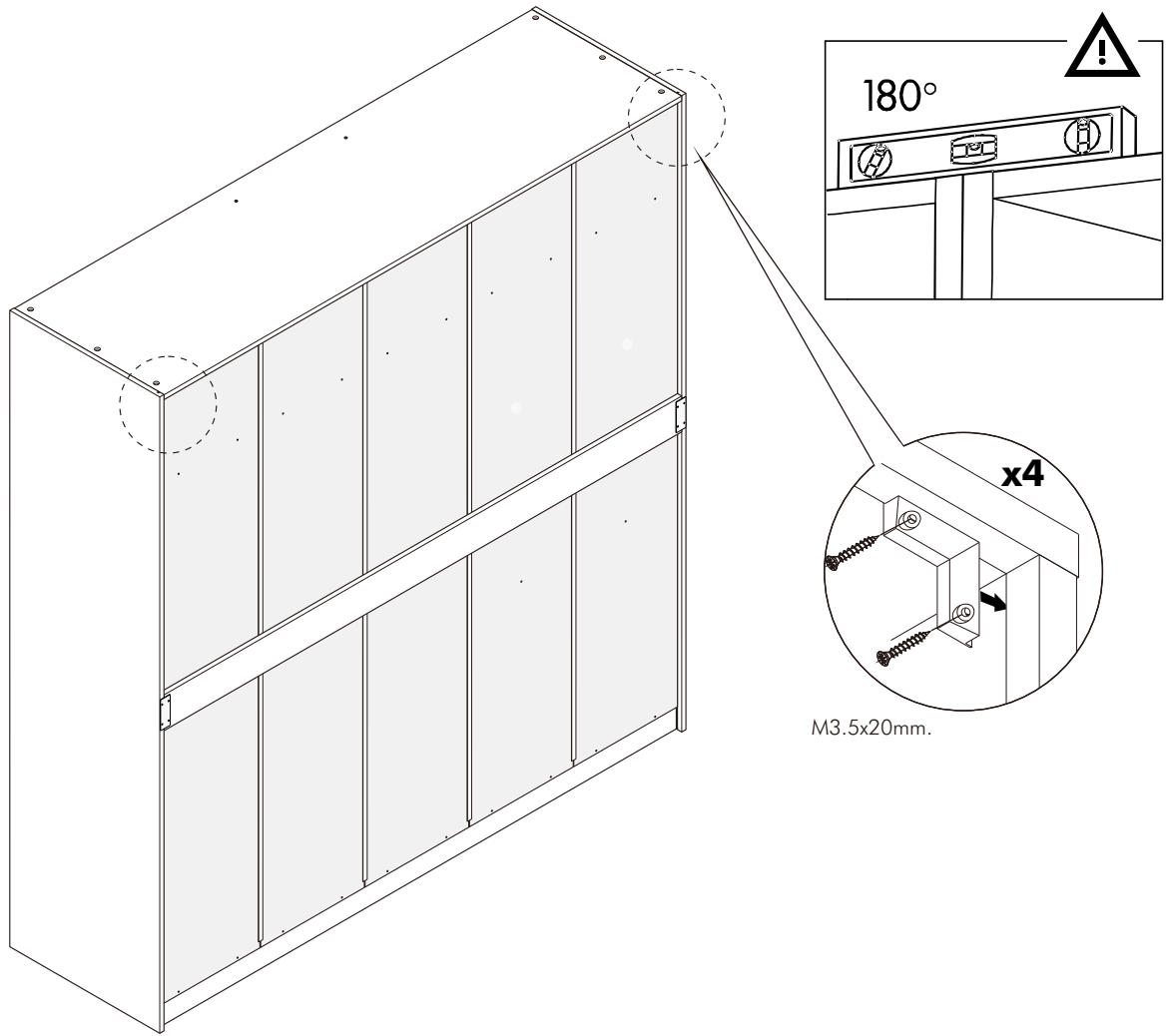

**24.**

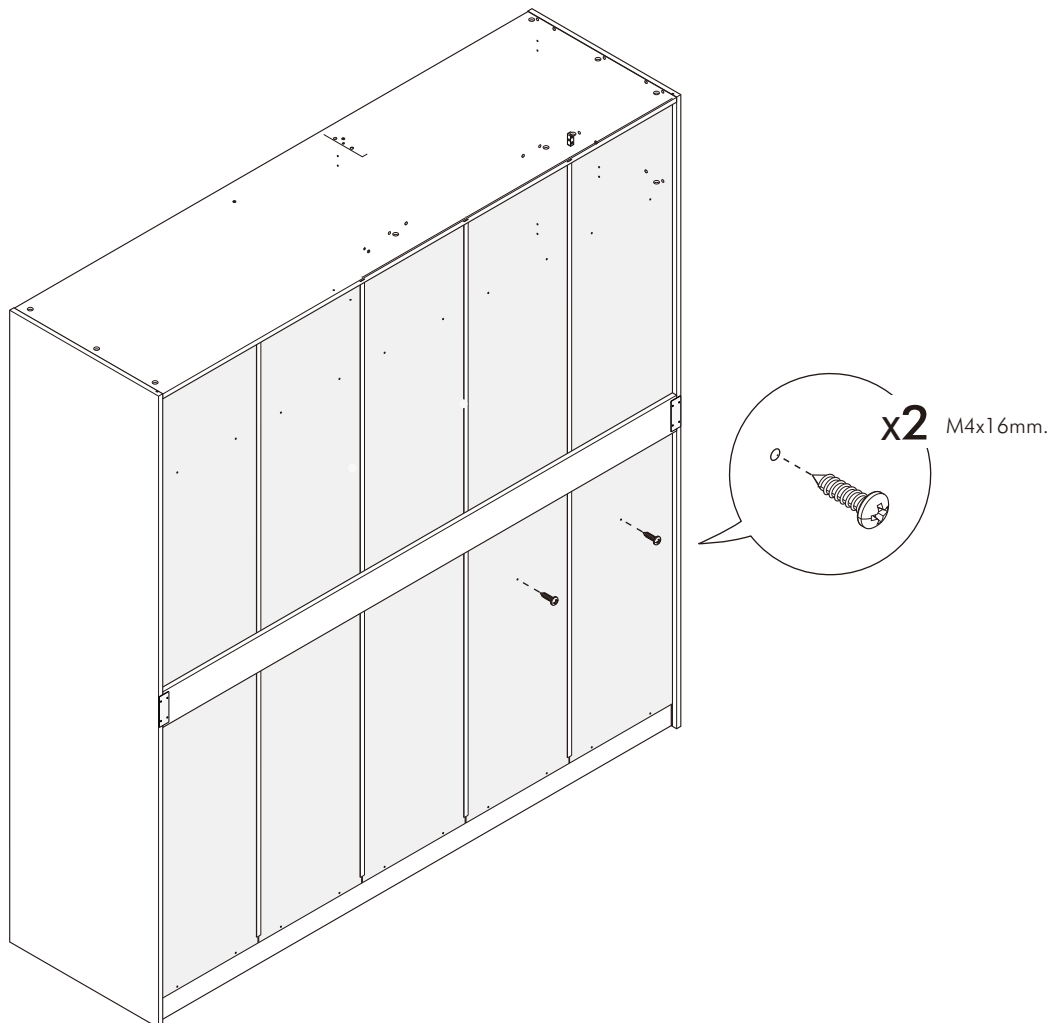

**25.**

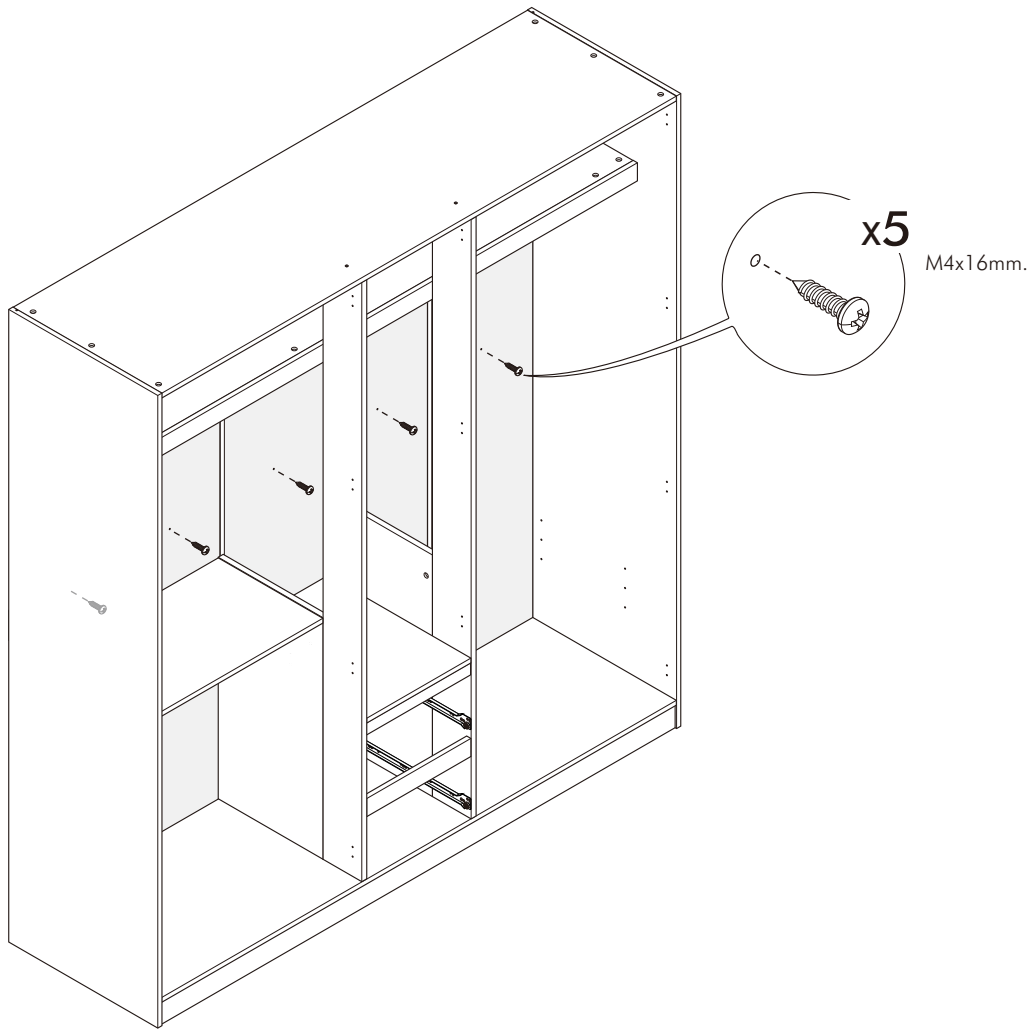

**26.**

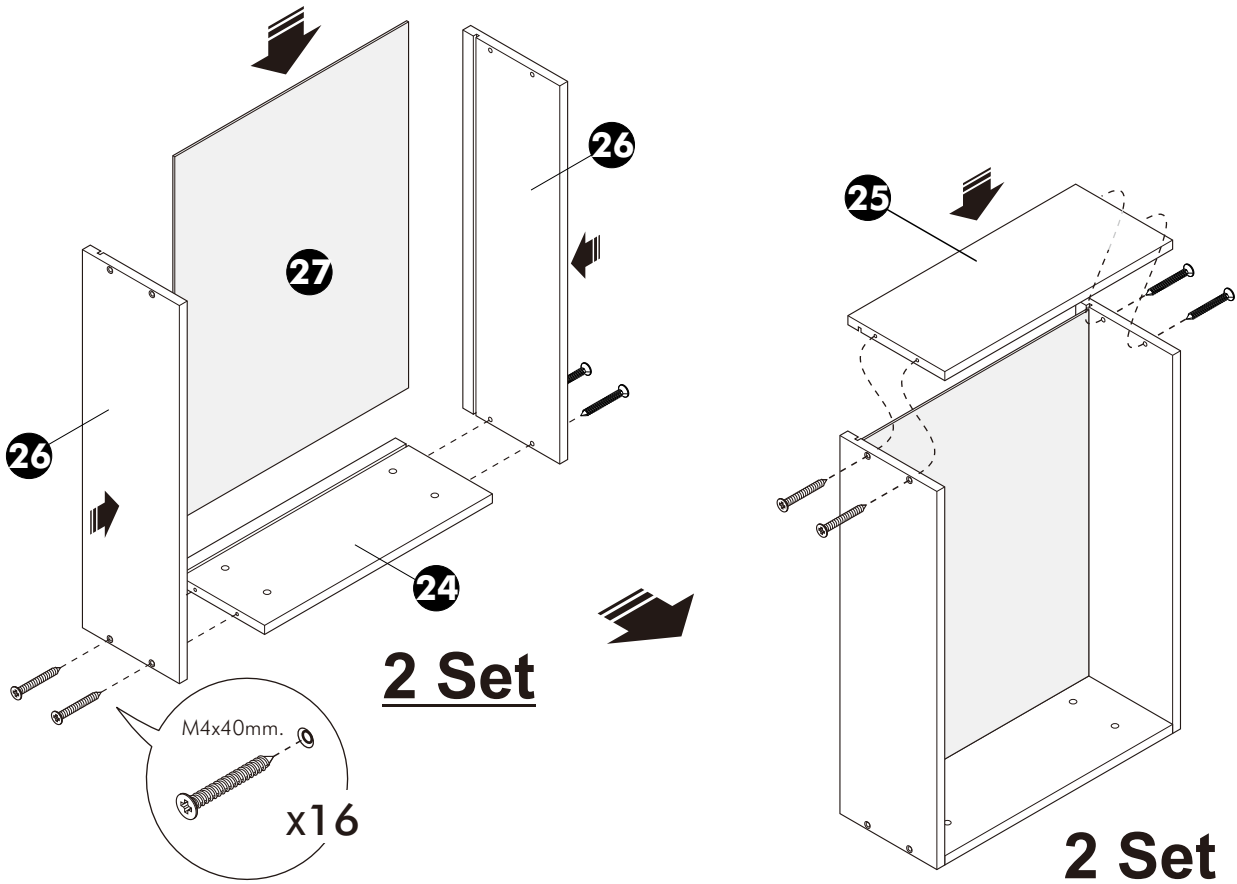

**27.**

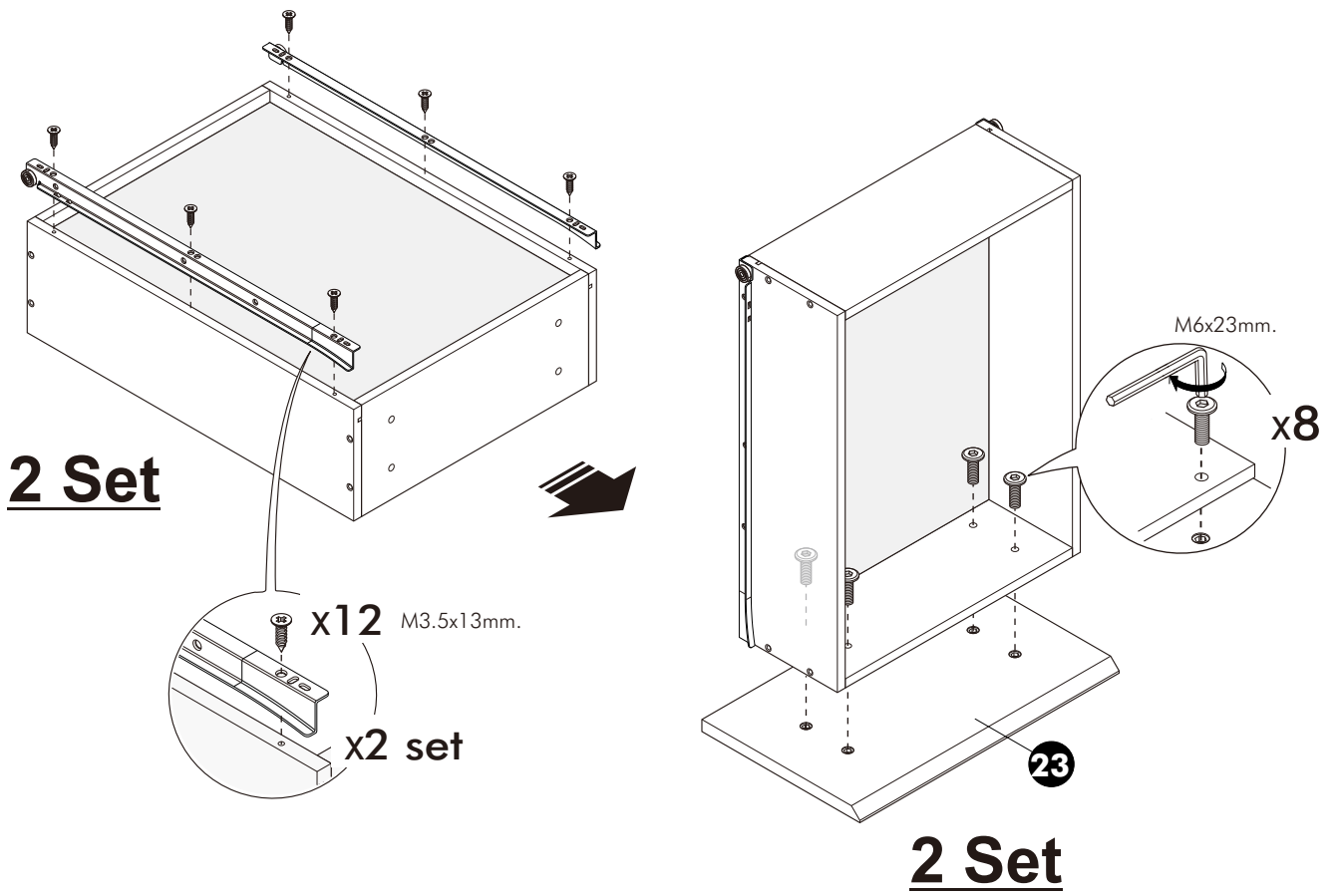

**28.**

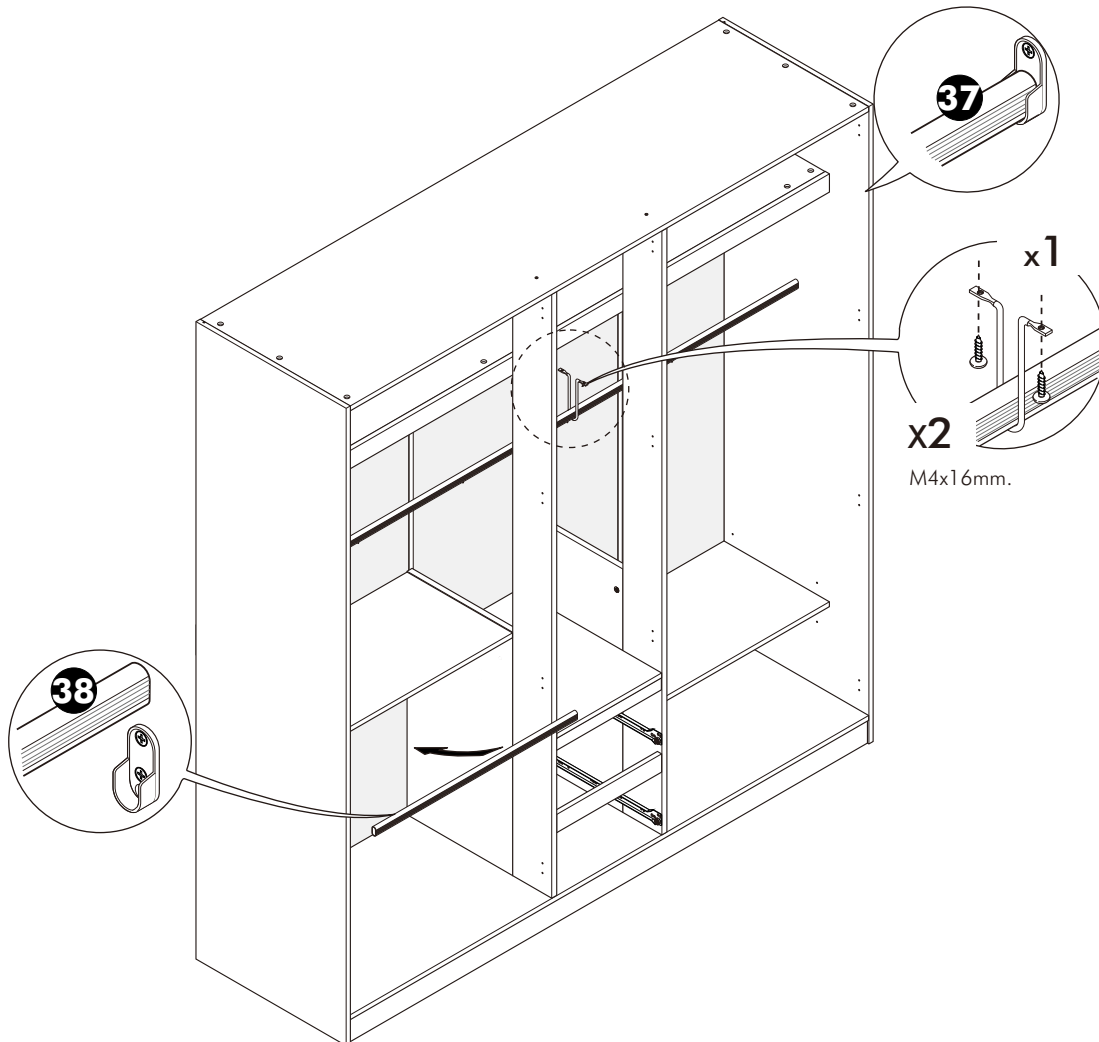

# 29.

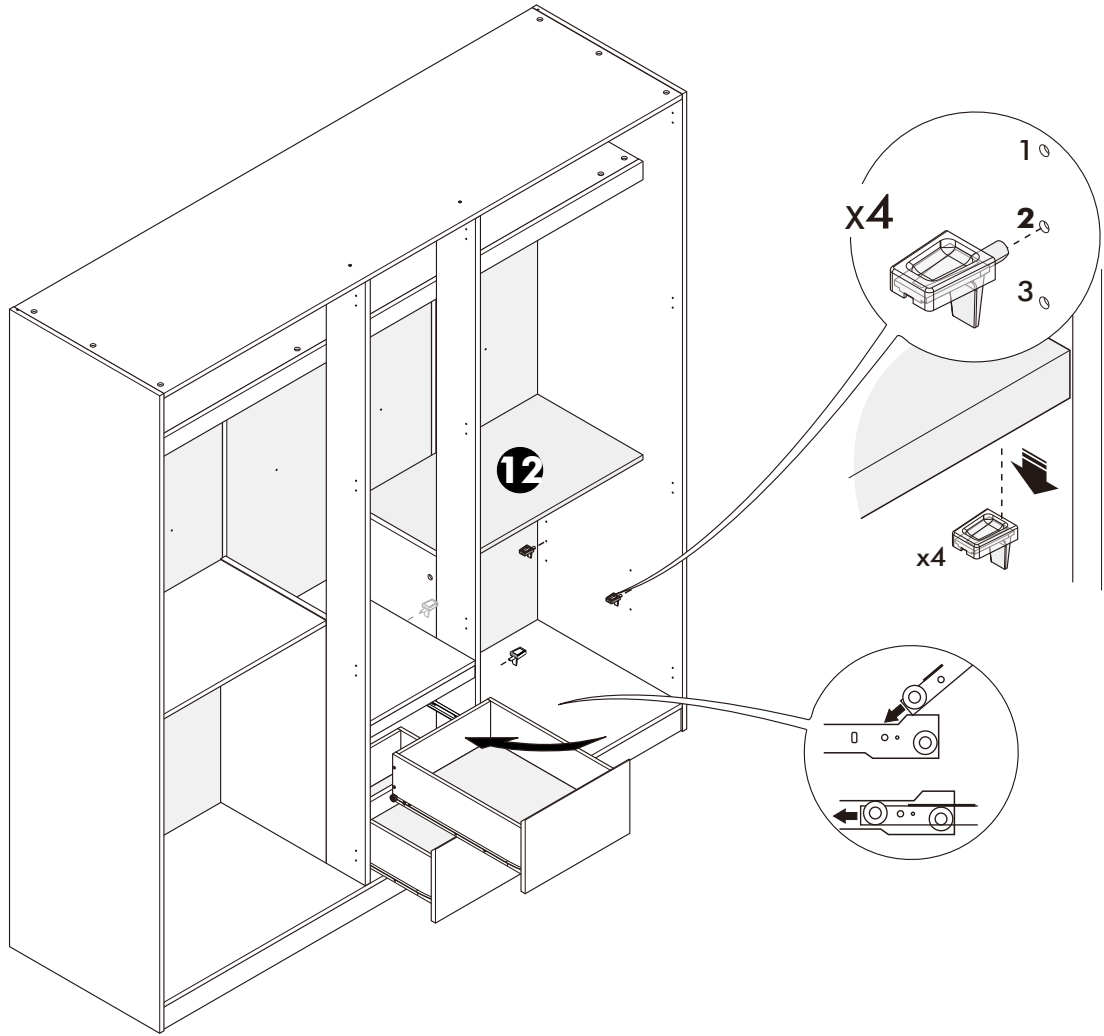

# 30.

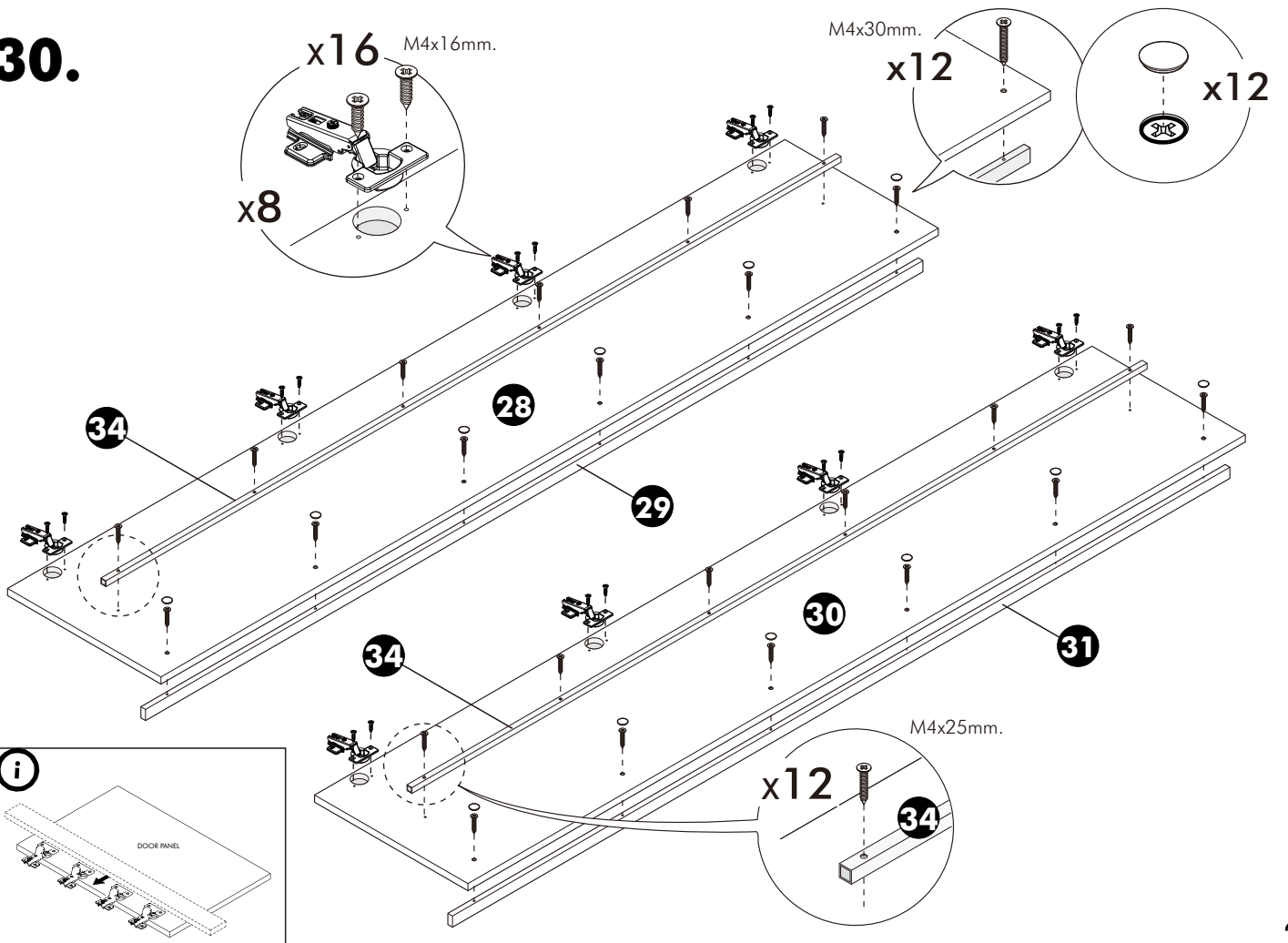



**33.**

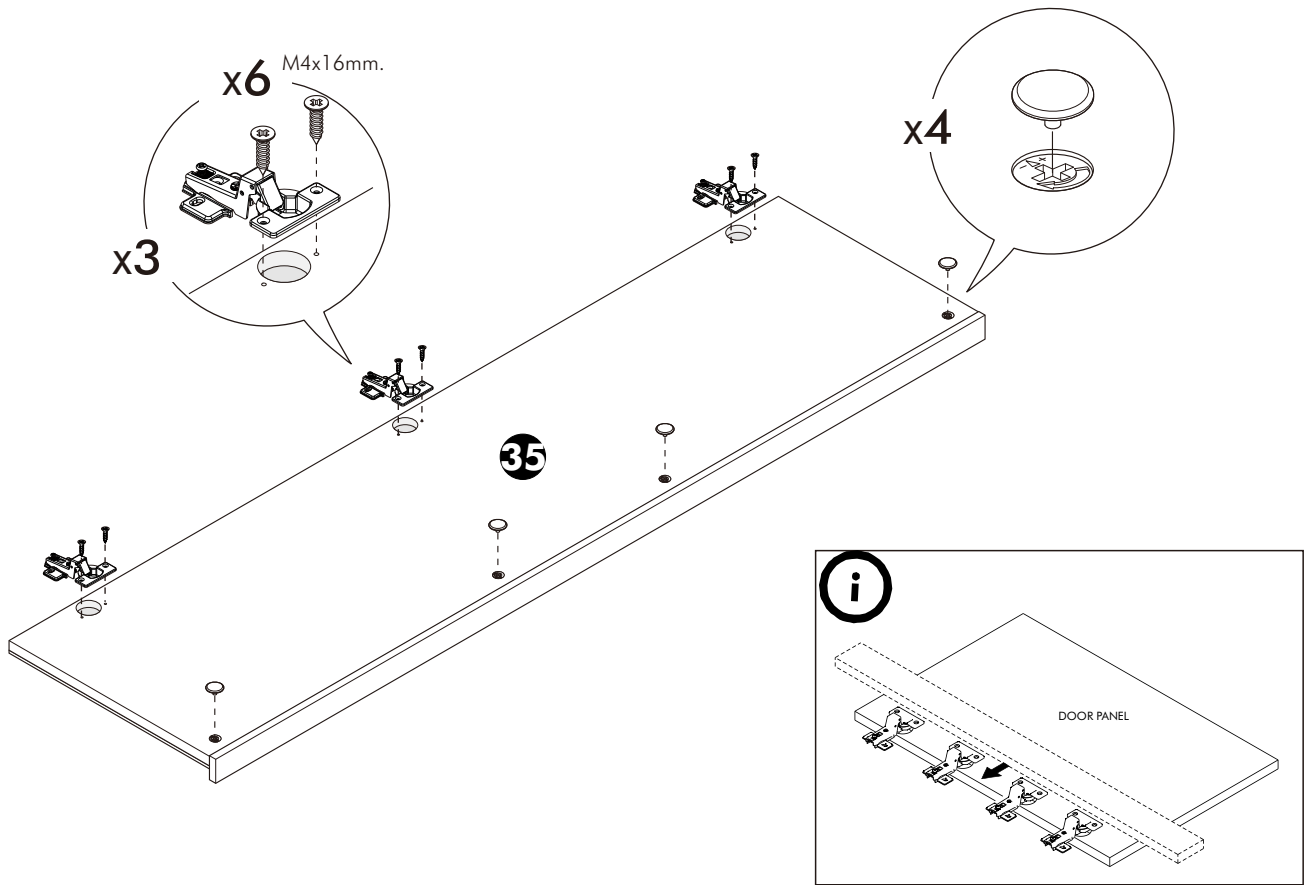

**34.**

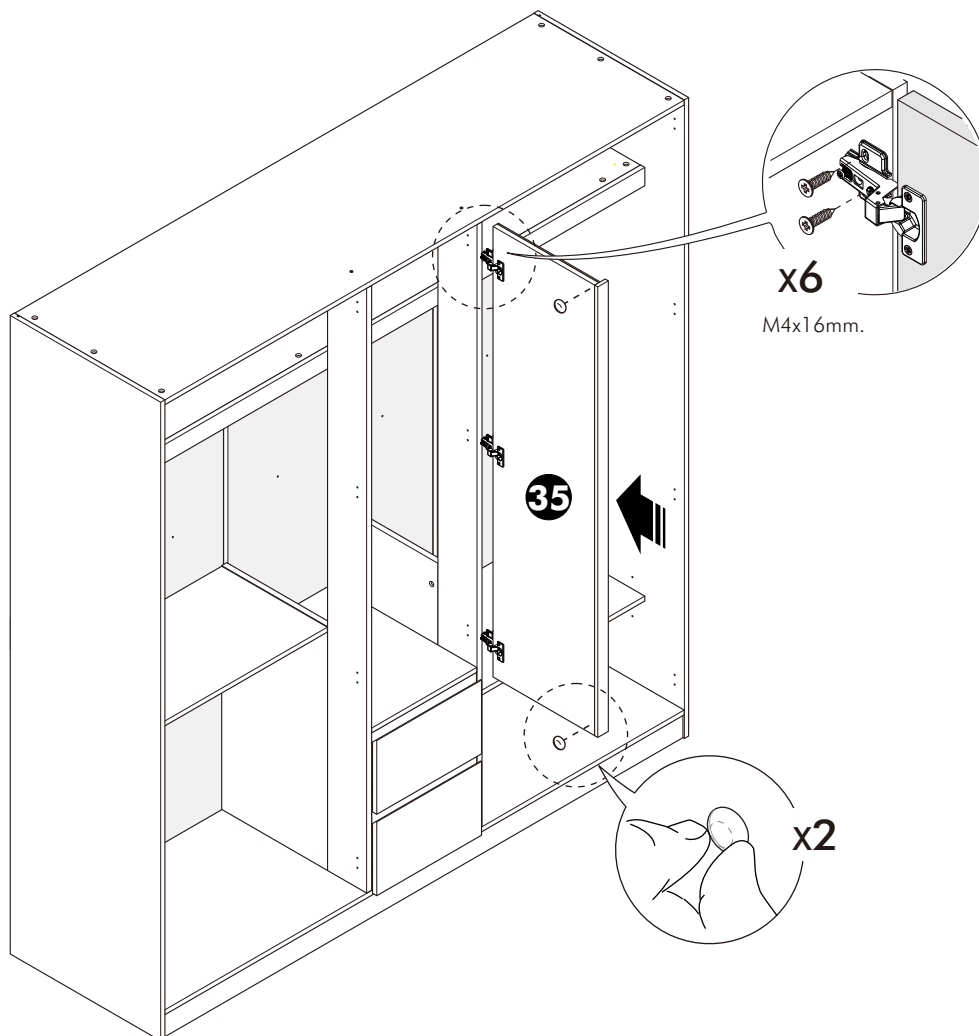

**35.**

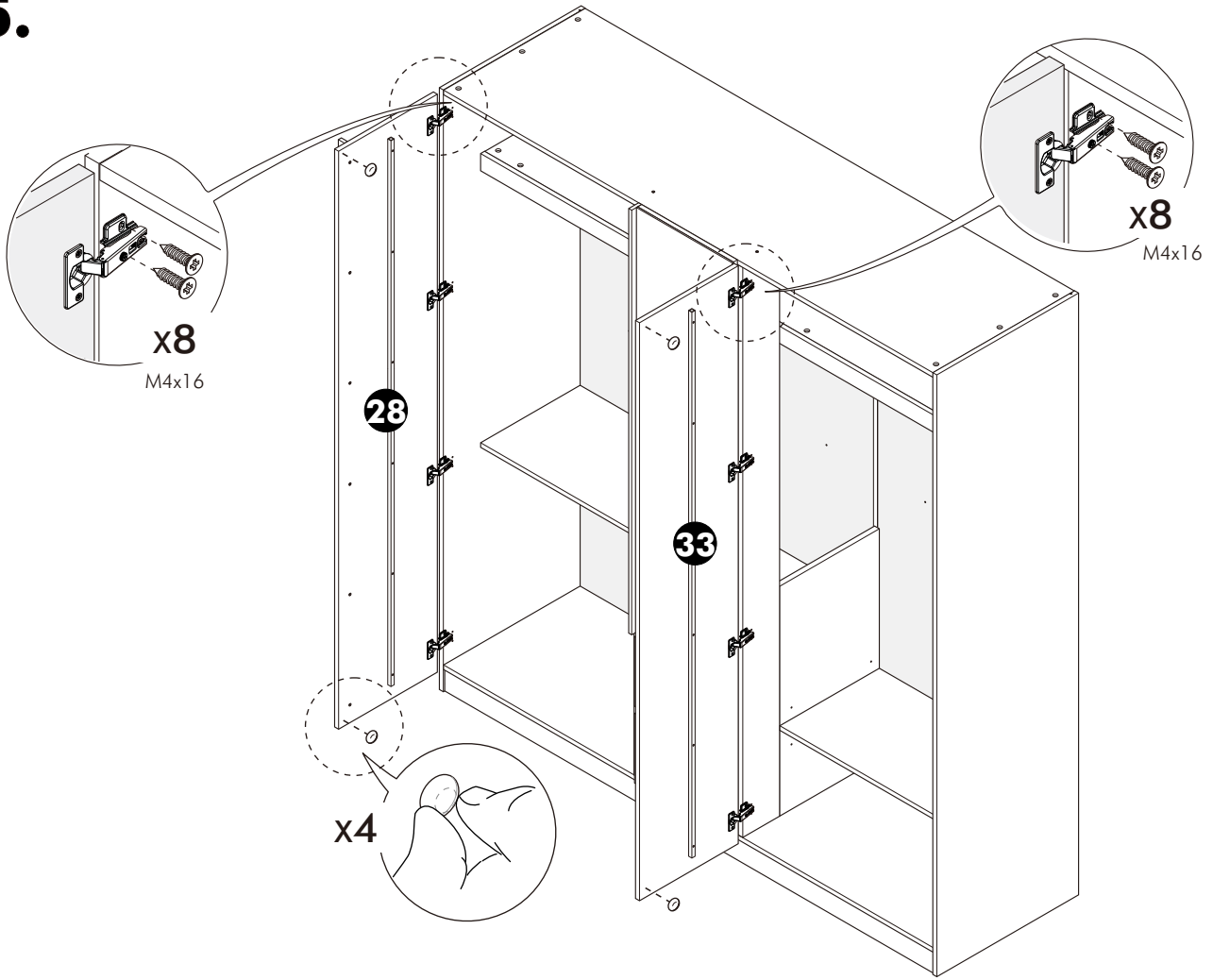

**36.**

