

# HARSH-P

Stand dresser 60 cm.

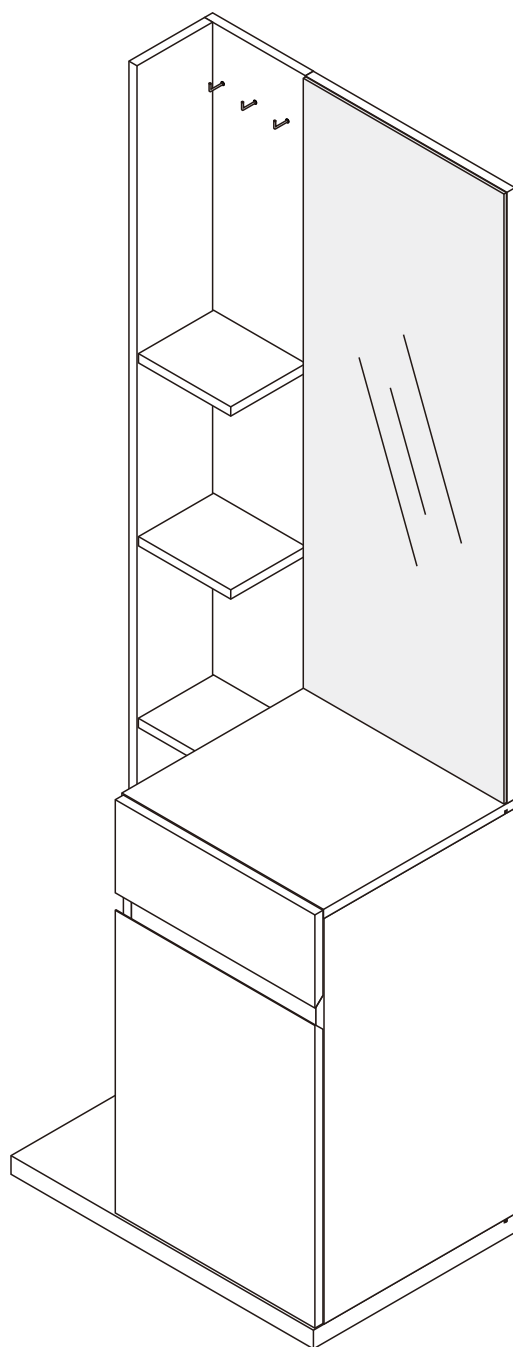

# CONNECT SYSTEM

**1**

**2**

(Connecting bolts)

**3**

**WHEN FITTING CAMS**  
ENSURE STARTING POSITION IS CORRECT  
BEFORE YOU INSERT CONNECTING BOLT  
TURN CLOCKWISE UNTIL SECURE

<p>✓</p> <p>↑ <b>CORRECT</b></p>	<p>✗</p> <p>↓ <b>WRONG</b></p>
--------------------------------------	------------------------------------

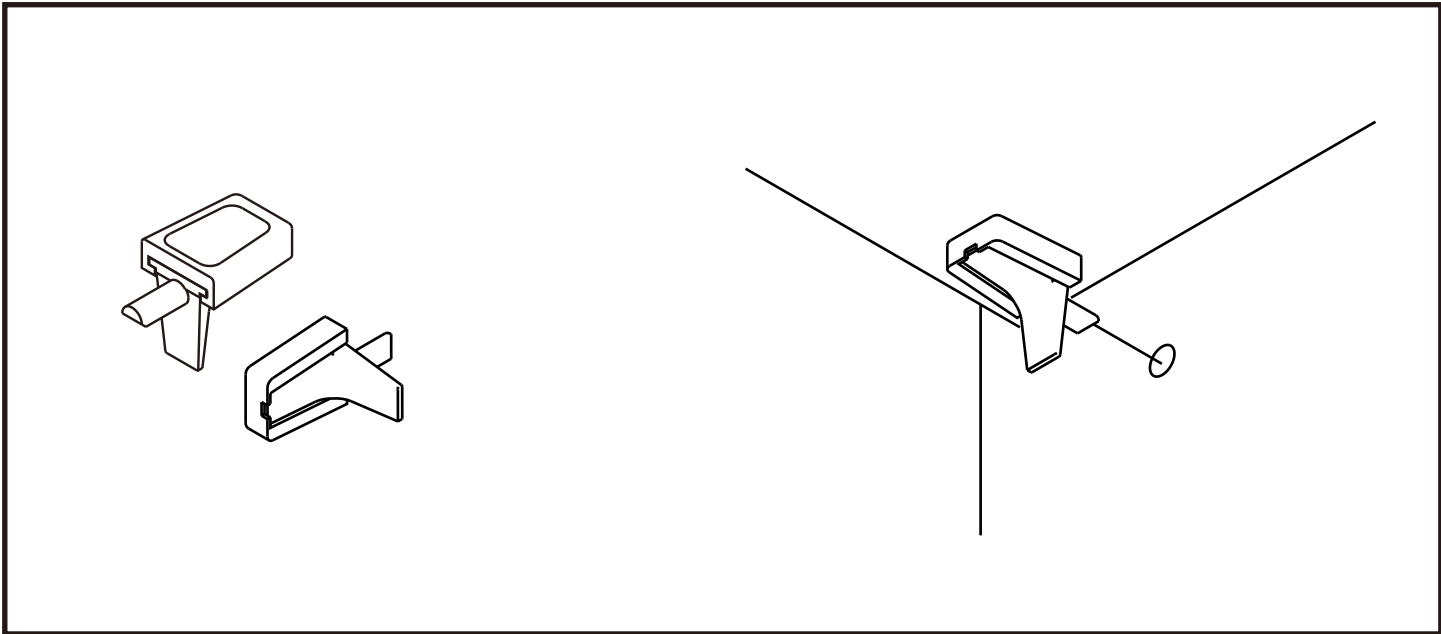

M3.5x13mm.

**1**

**2**

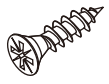

M4x16mm.



DOOR PANEL

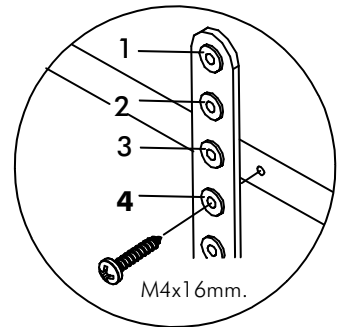
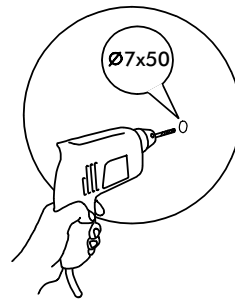
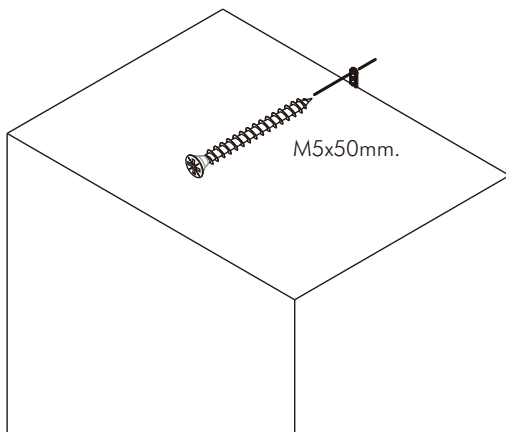
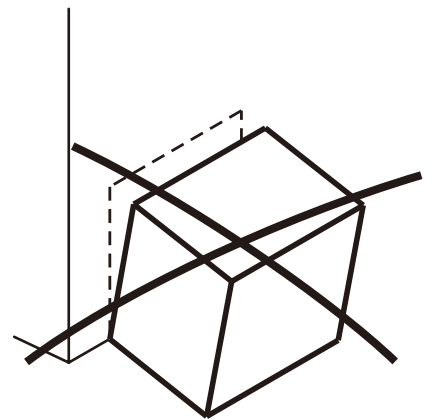
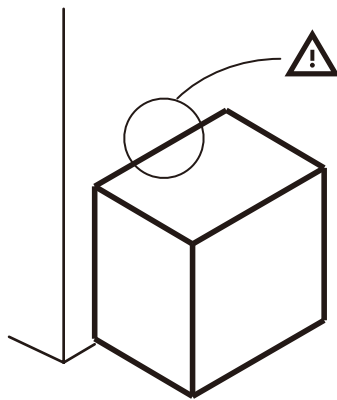
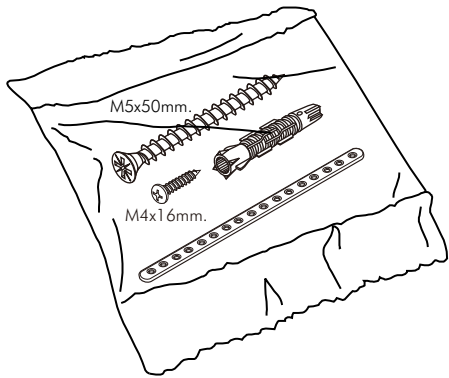
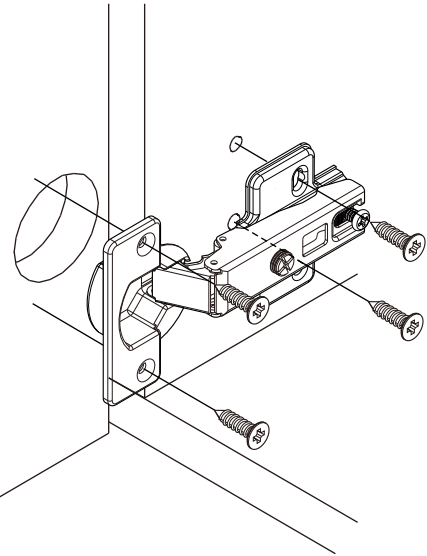
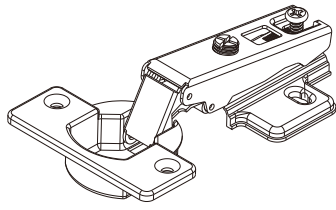
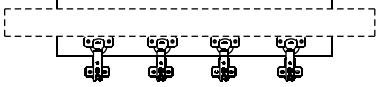

# HARDWARE

## -BODY SET

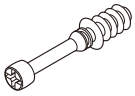

**x 12**



**x 12**

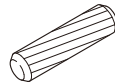

**x 28**

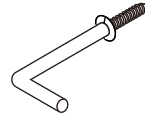

**x 3**



**x 3**



M4x16mm.

**x 12**

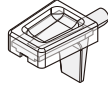

**x 4**

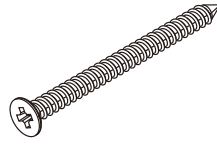

M4x50mm.

**x 21**

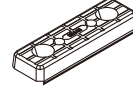

**x 6**



M3.5x13mm.

**x 6**

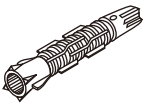

**x 1**

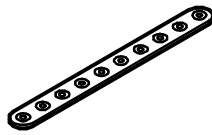

**x 1**

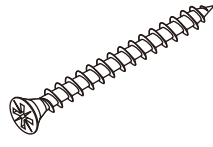

M5x50mm.

**x 1**



M4x16mm.

**x 1**

## -DRAWER SET

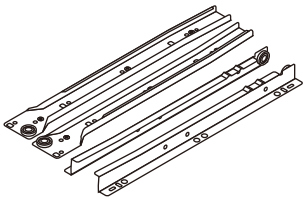

**x 1**



M3.5x13mm.

**x 14**

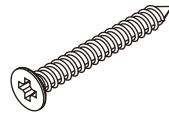

M4x40mm.

**x 8**



TFL4 M6x23

**x 2**



**x 1**



**x 2**

## -DOOR SET

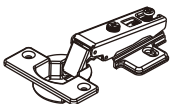

**x 2**



M4x16mm.

**x 8**



**x 2**

# ASSEMBLY

-BODY SET

1.

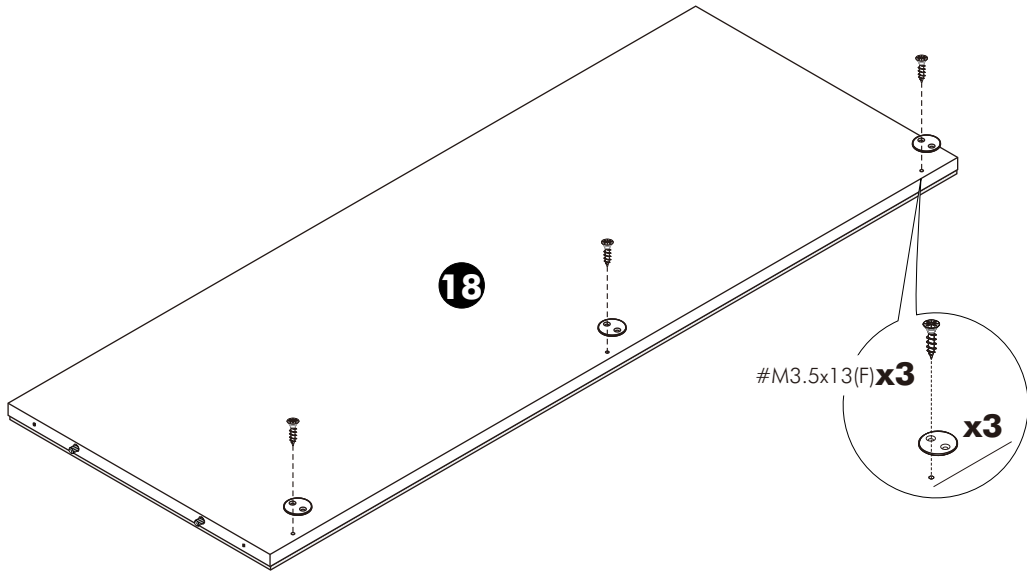

2.

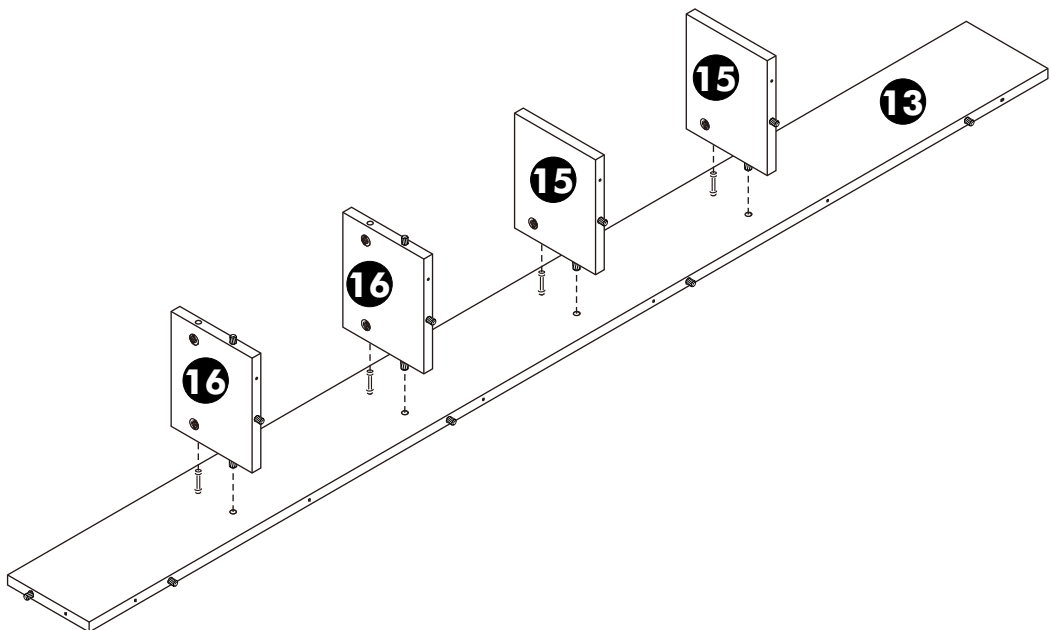

**3.**

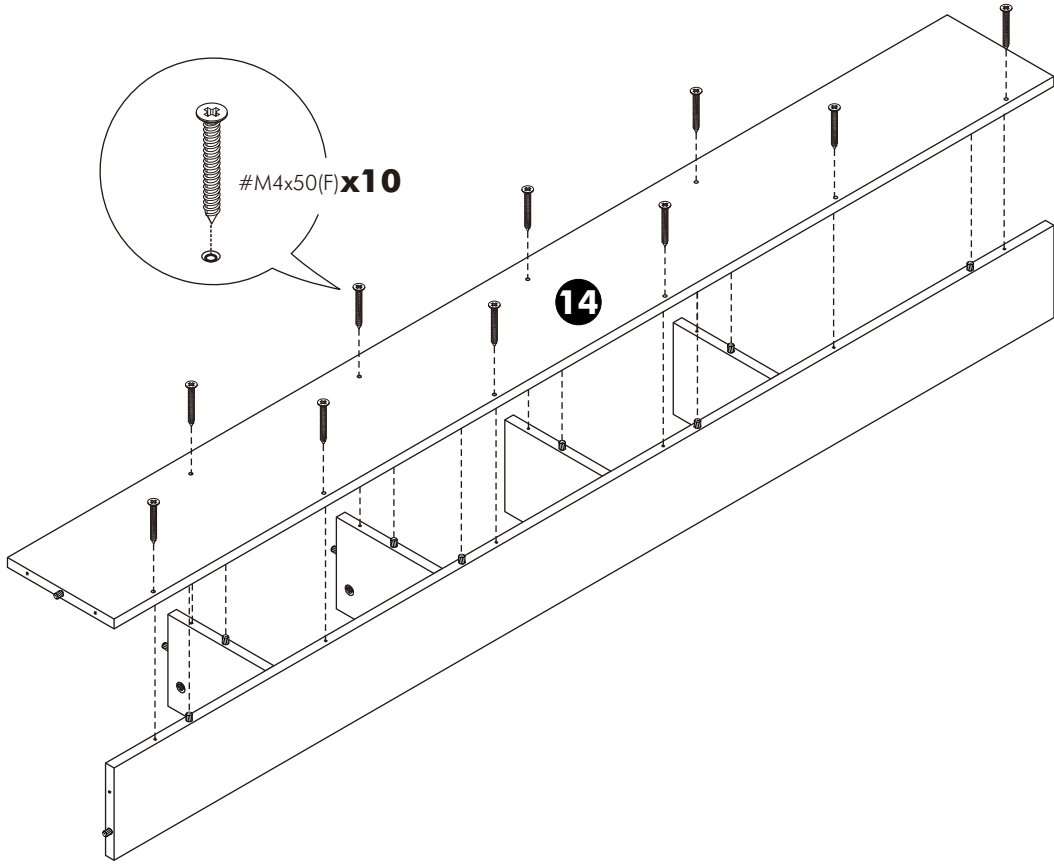

**4.**

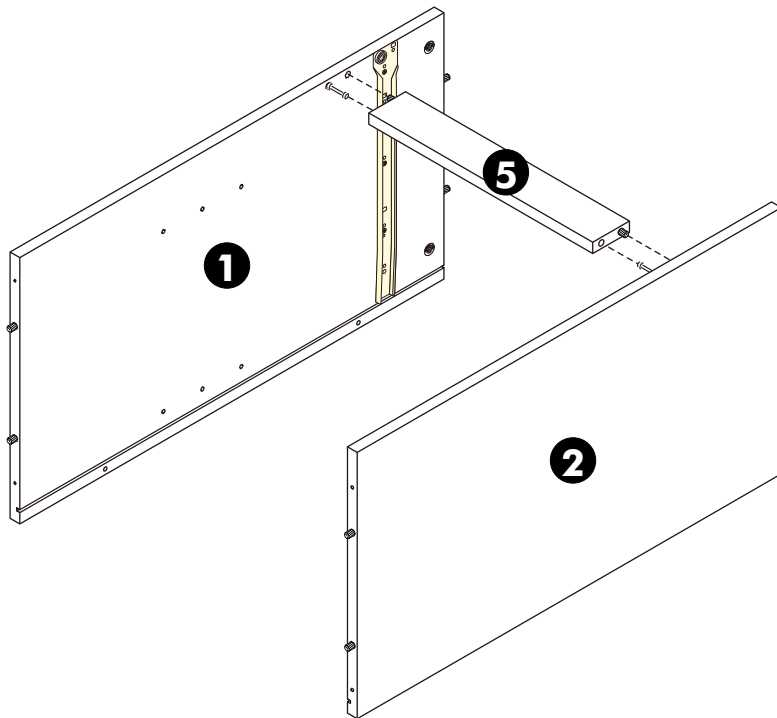

**5.**

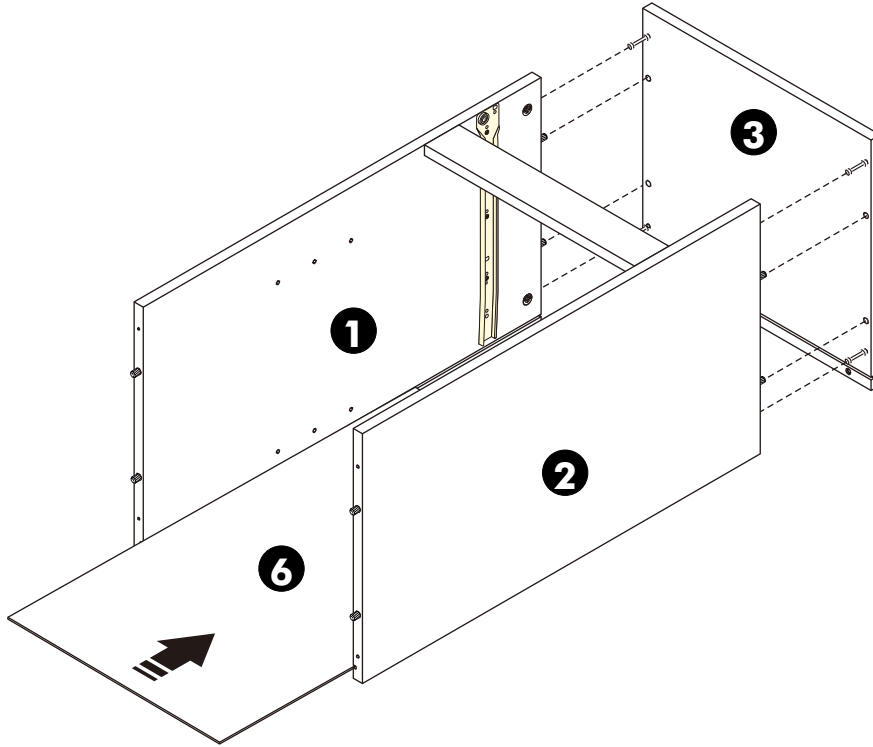

**6.**

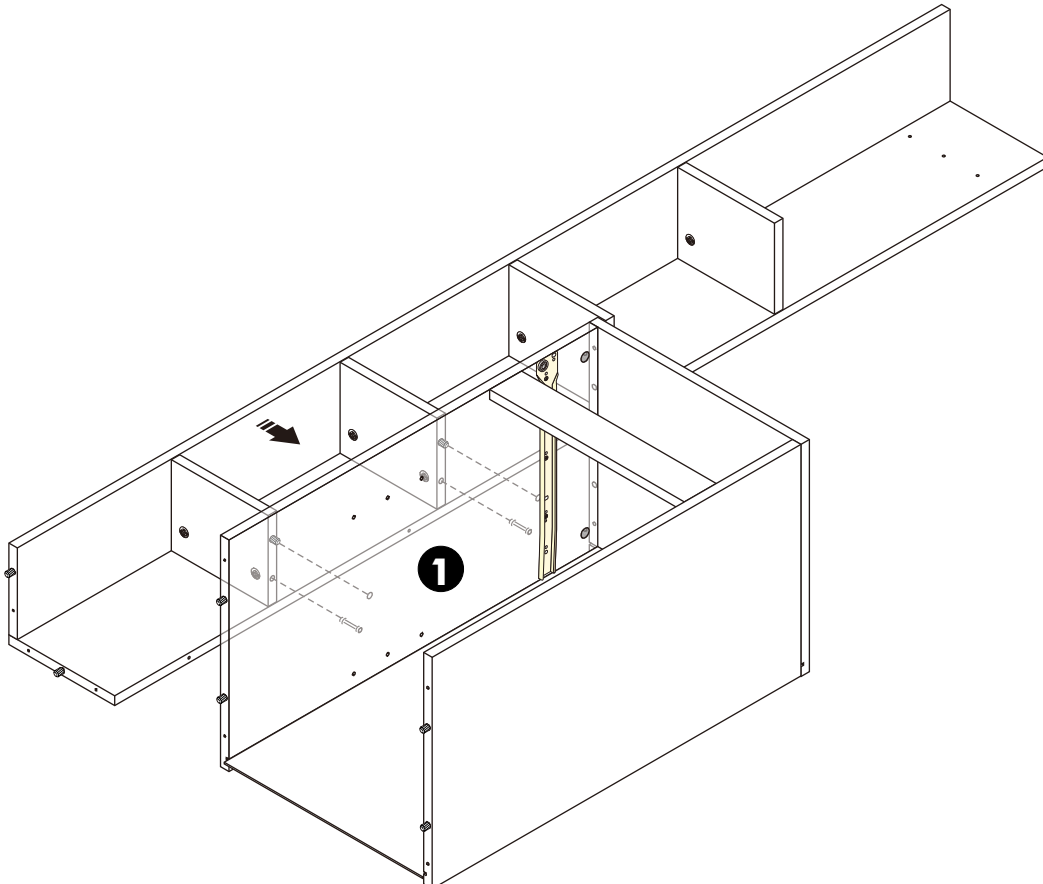

**7.**

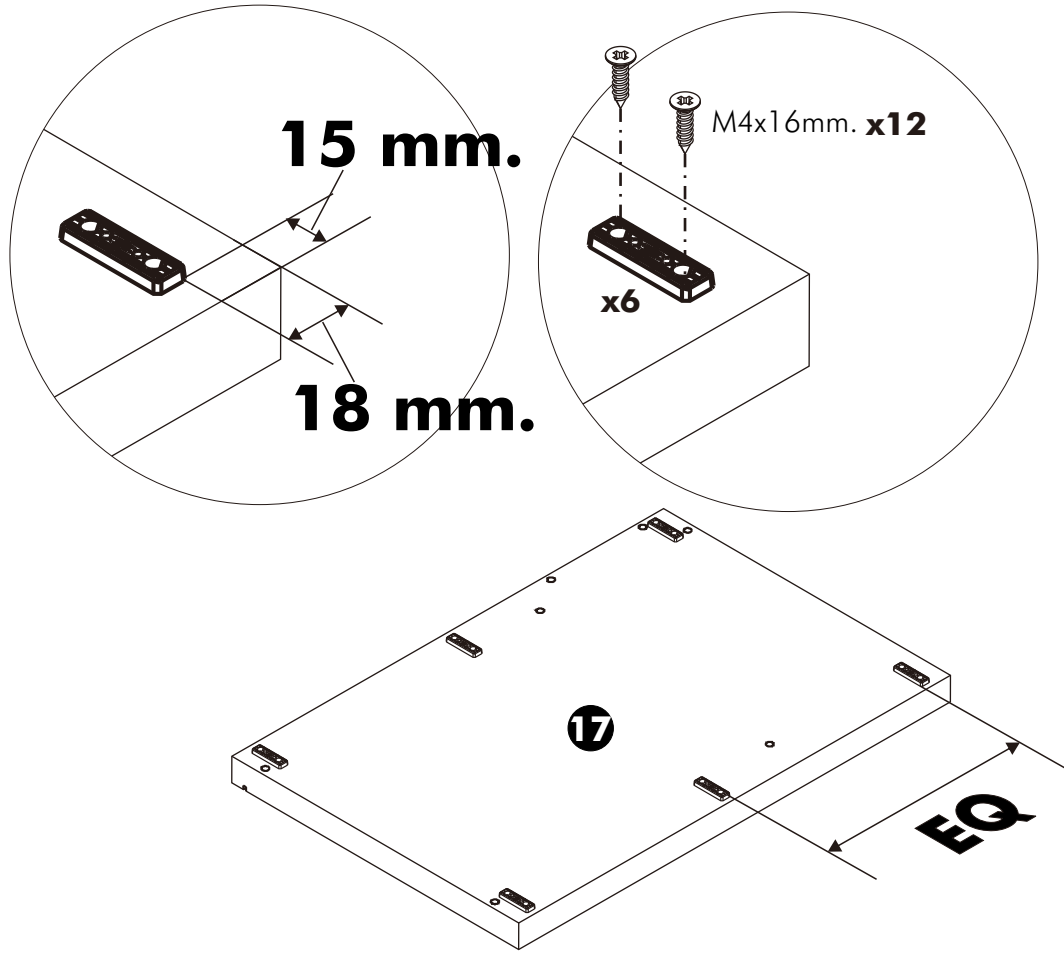

**8.**

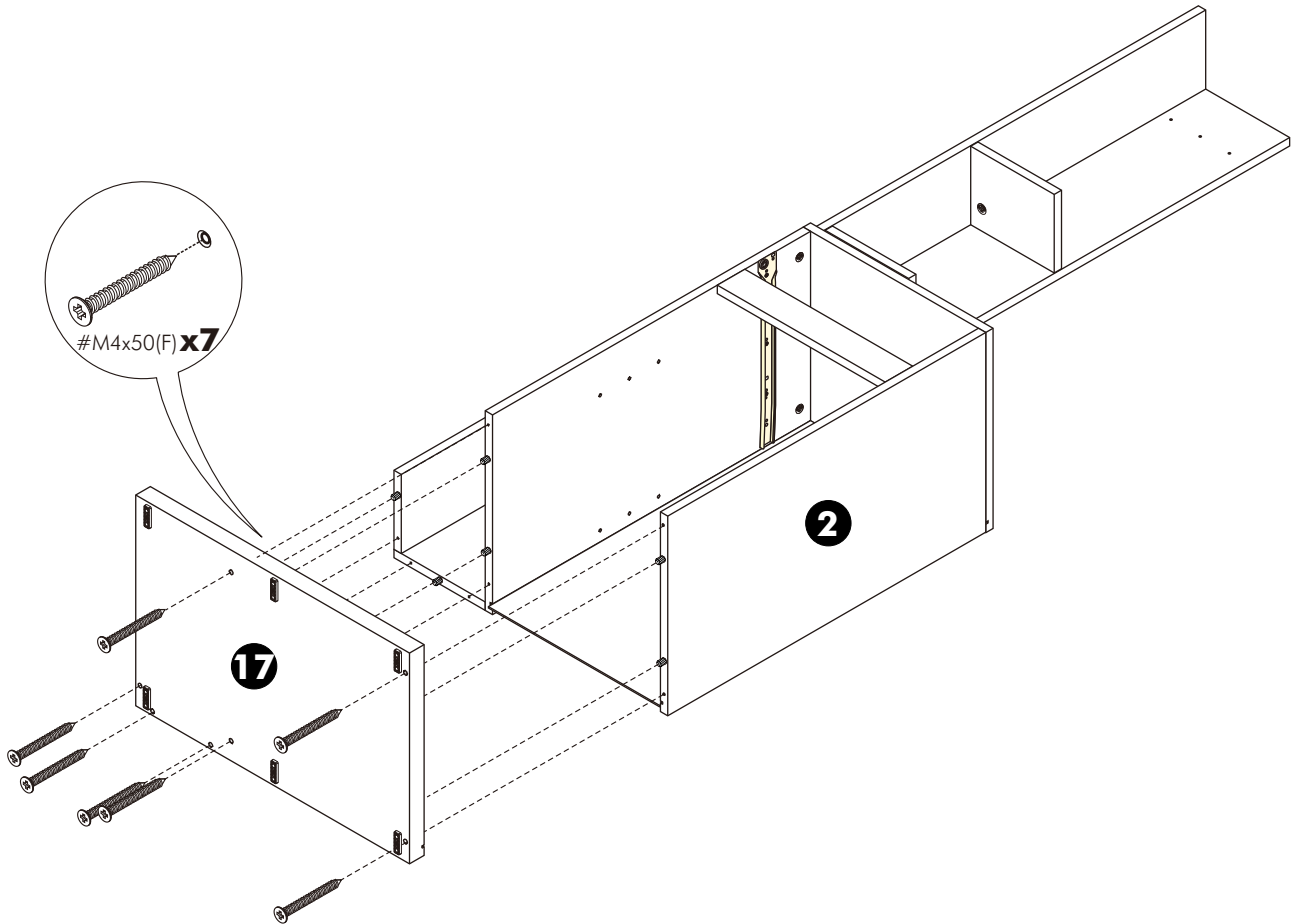

9.

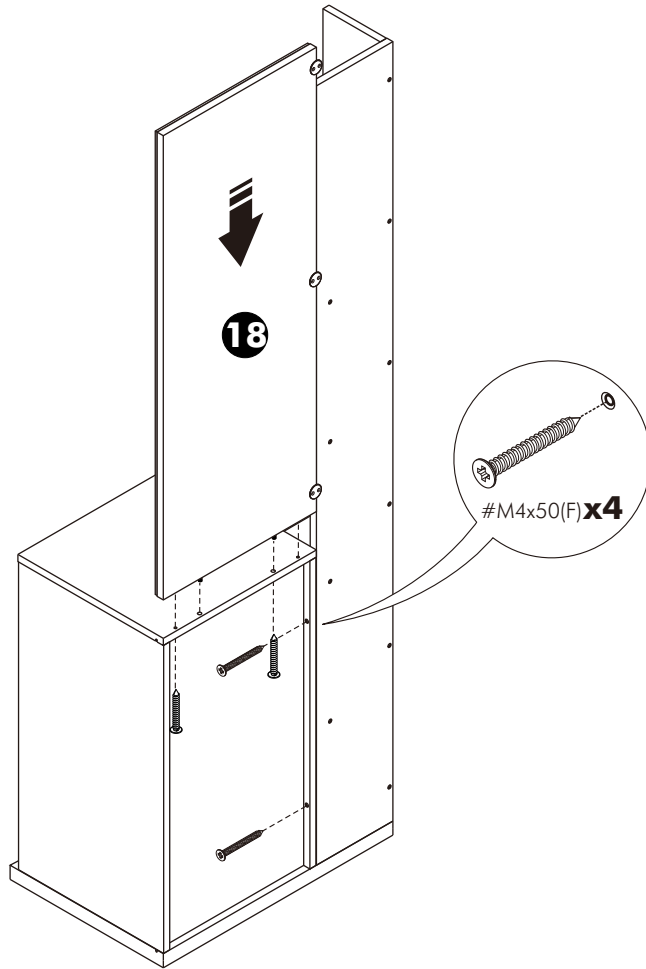

10.

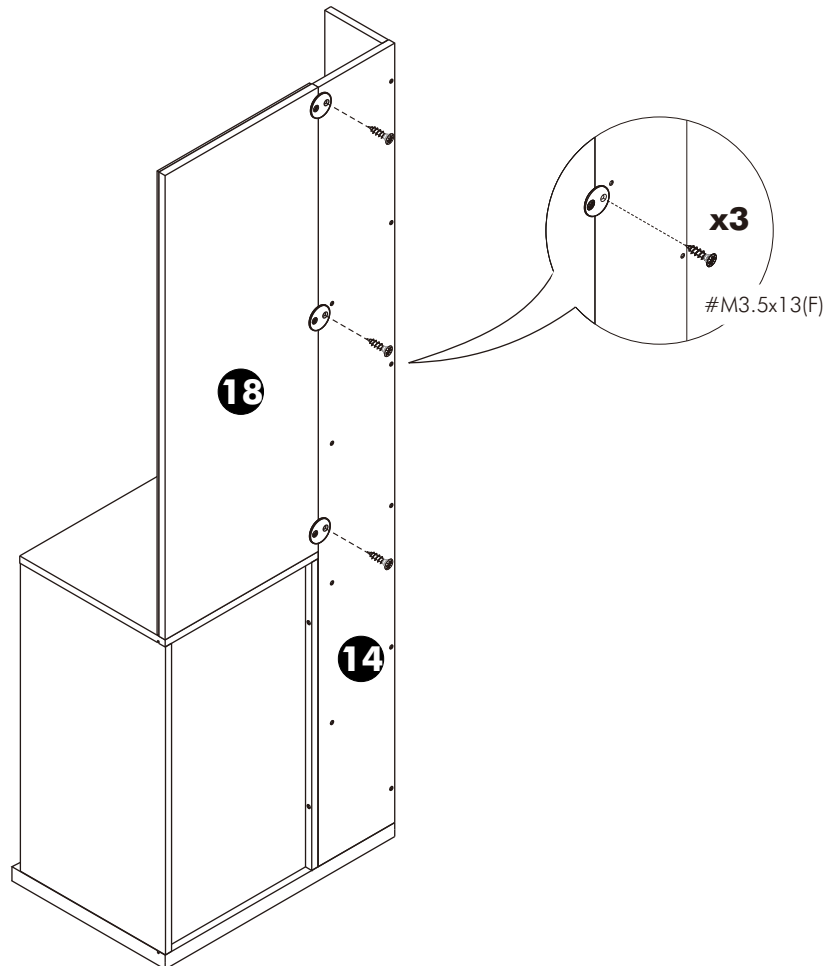

# 11.

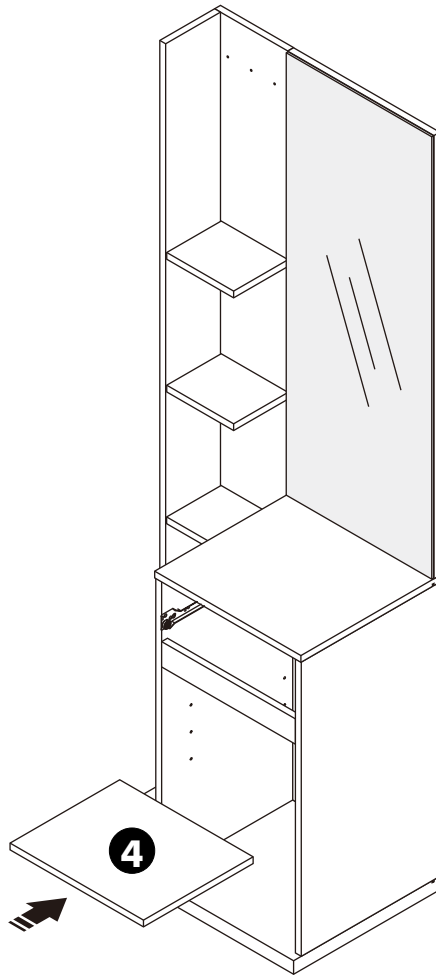

## ASSEMBLY

-DRAWER SET

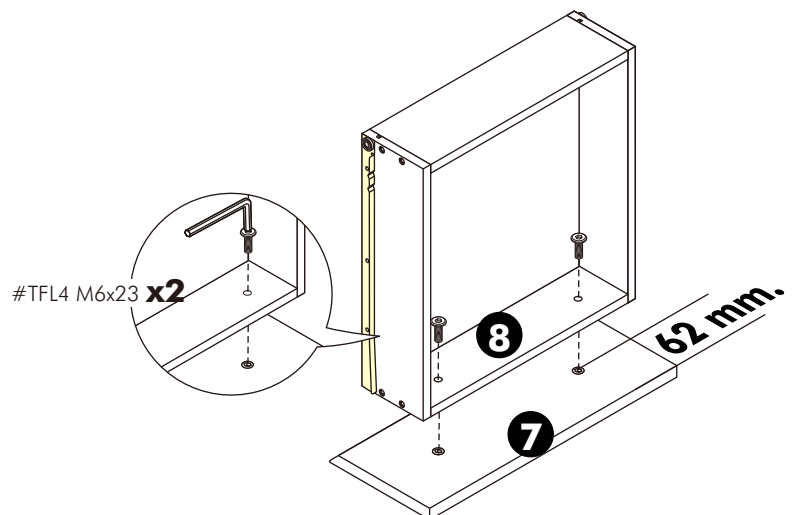
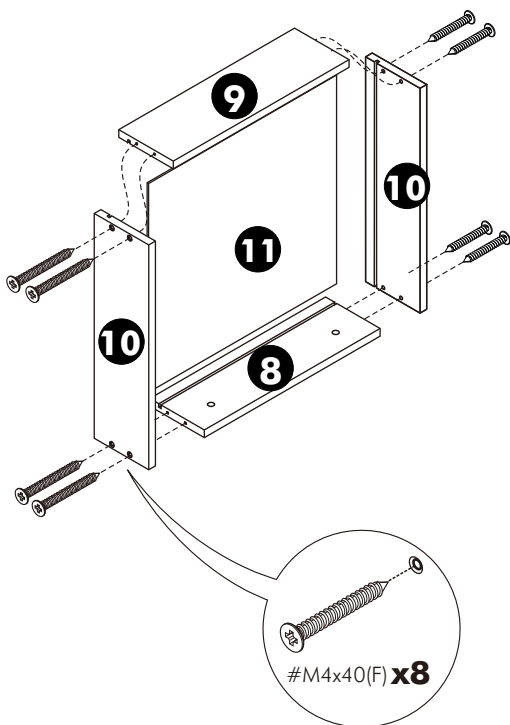

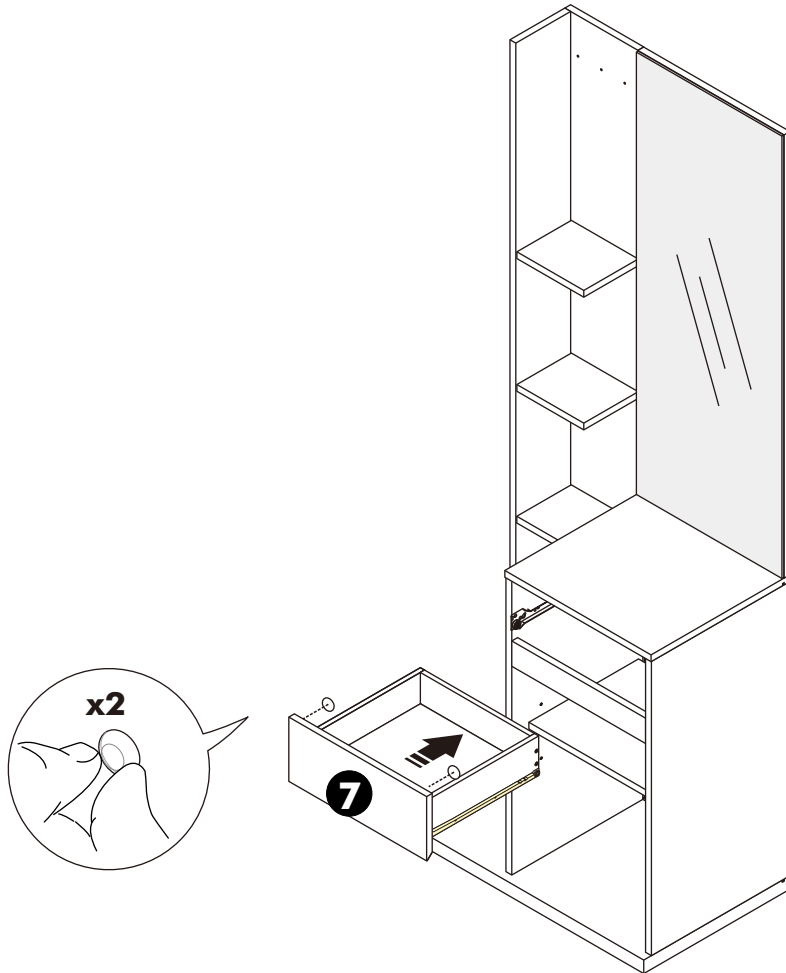

**ASSEMBLY**

-DOOR SET

