

# CO-SPENCER

TV Cabinet 150 cm.

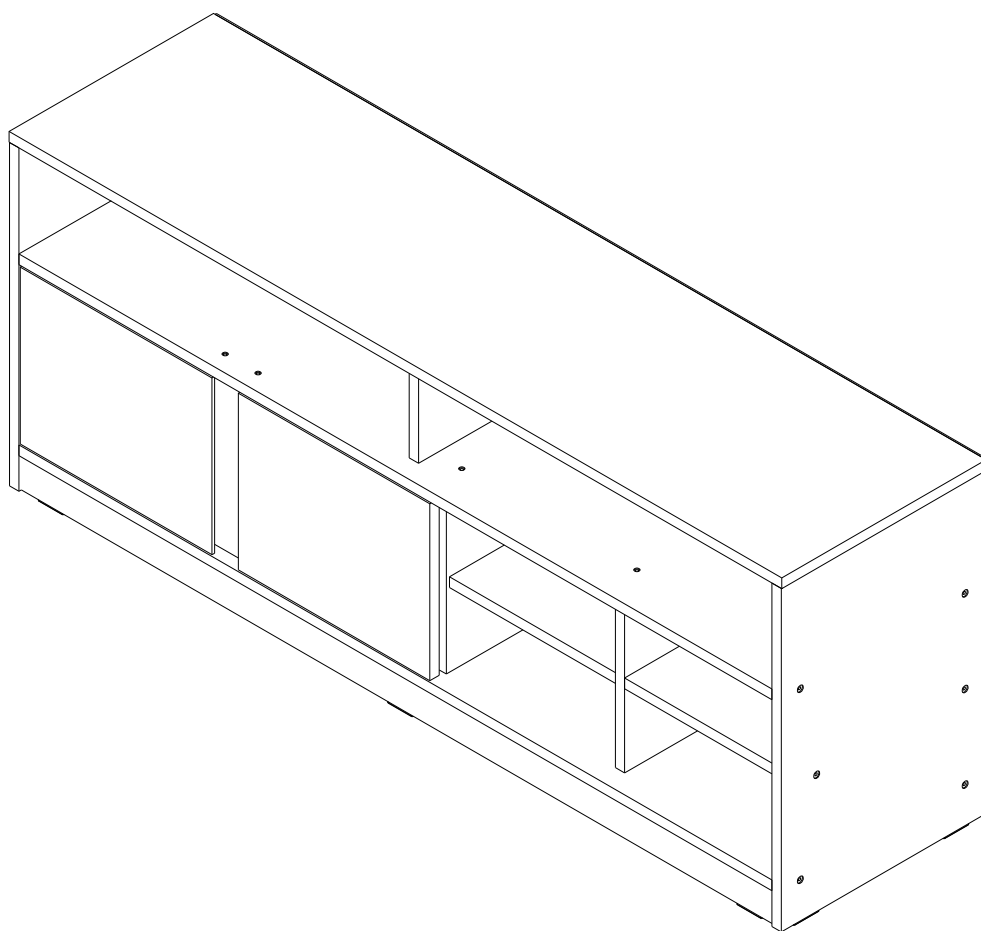

# CONNECT SYSTEM

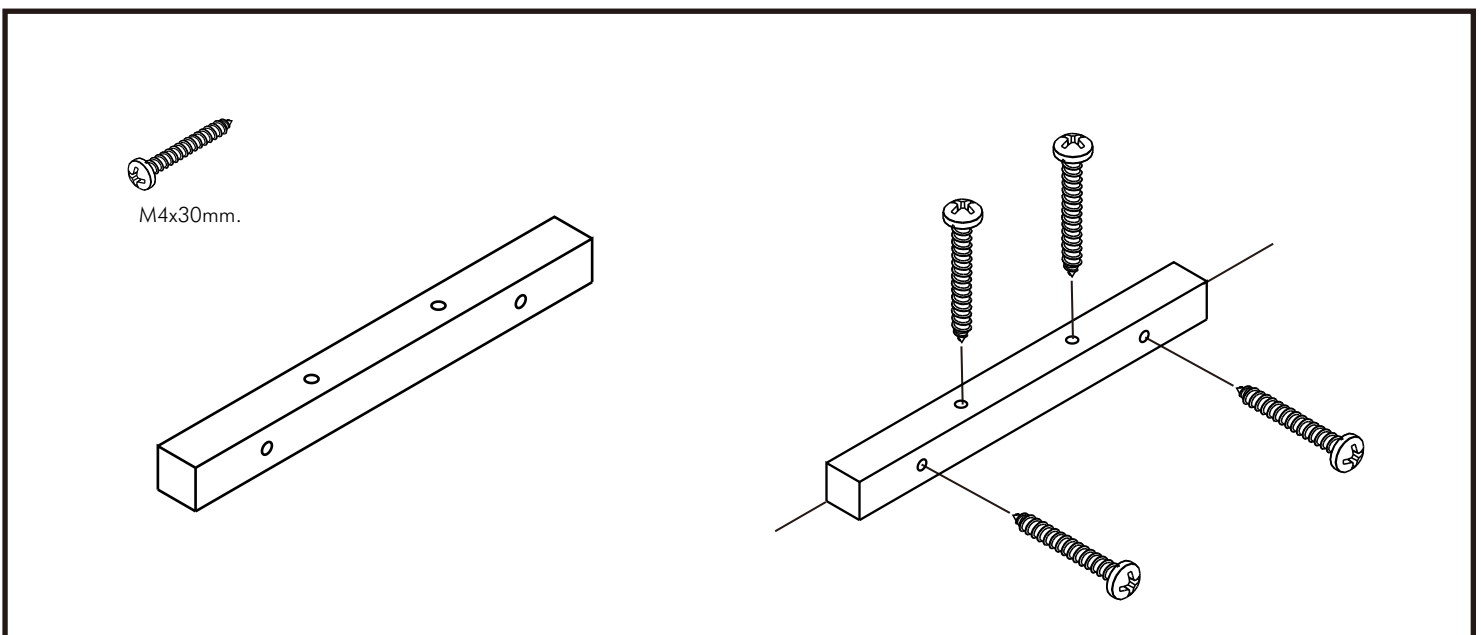
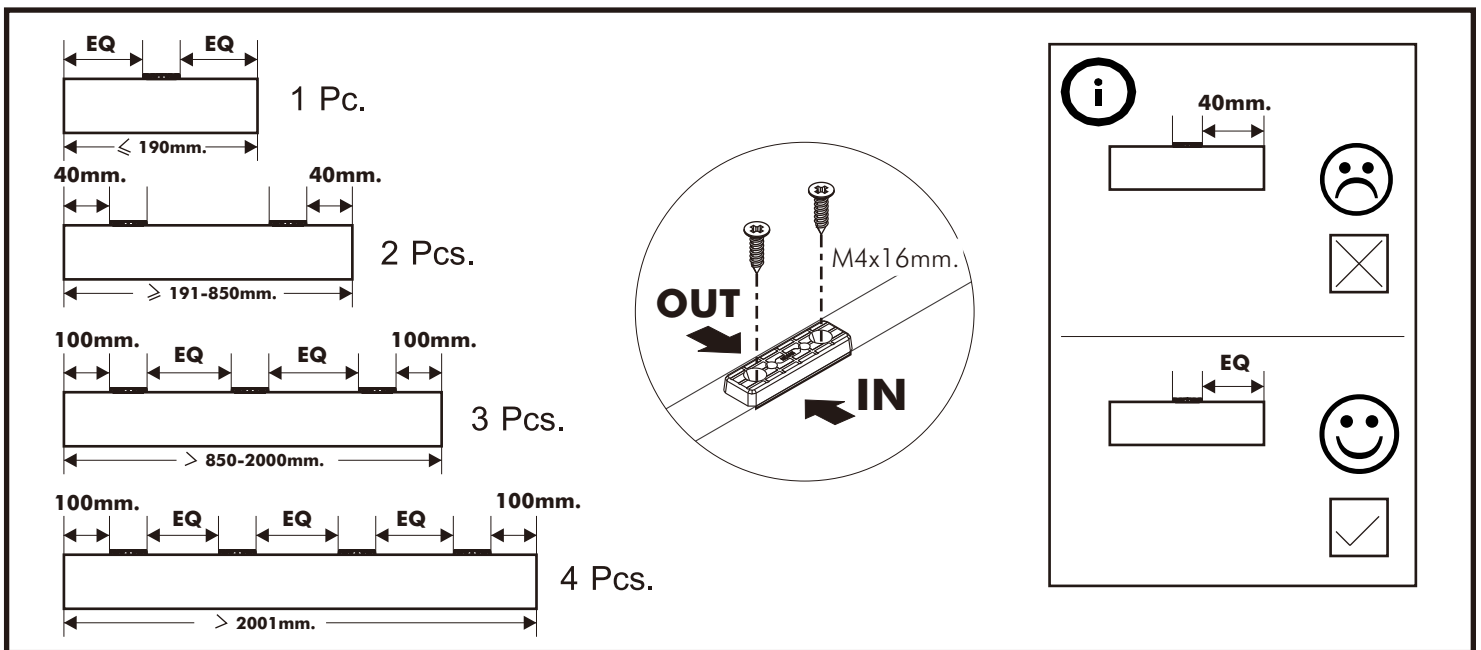
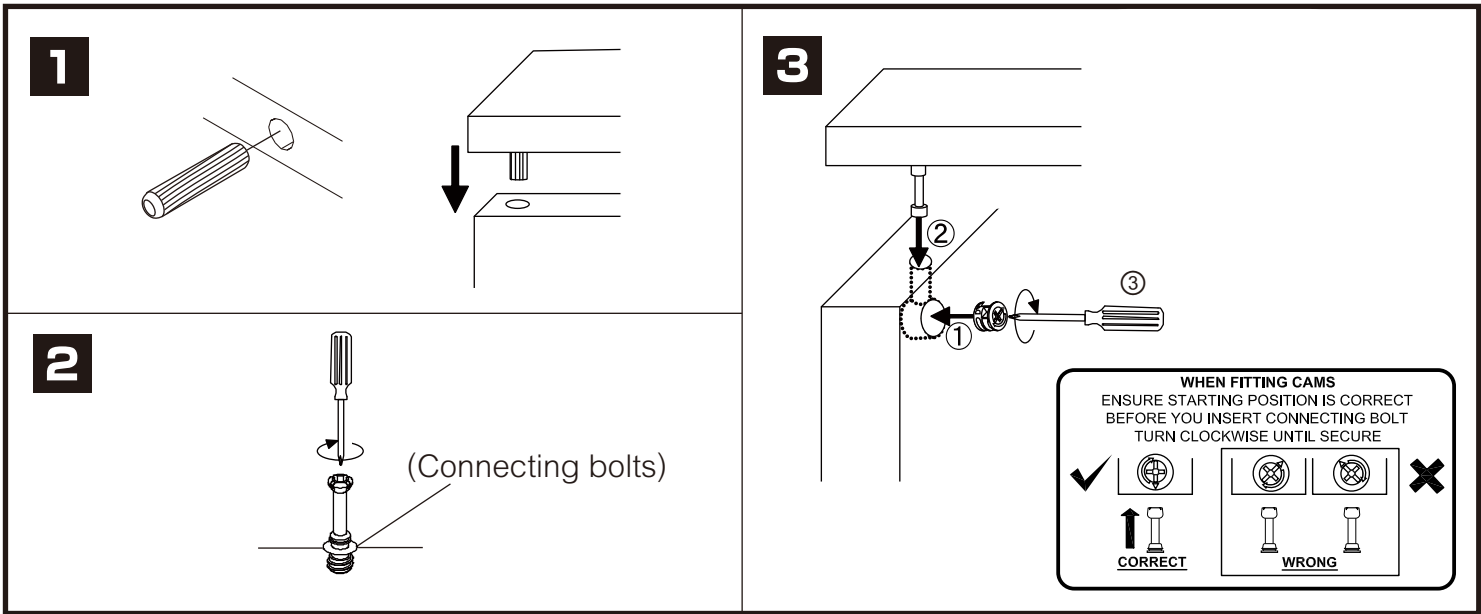

# HARDWARE

## -BODY SET

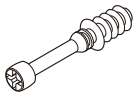

**x 6**



**x 6**



8x35mm.

**x 32**

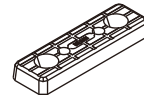

**x 10**

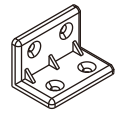

**x 6**

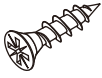

M4x16mm.

**x 44**



**x 2**

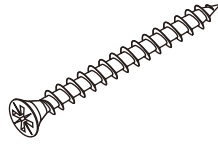

M4x50mm.

**x 26**



**x 6**

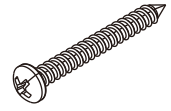

M4x30mm.

**x 20**



**x 20**



M4x20mm.

**x 4**



**x 18**



**x 4**

## -DOOR SET

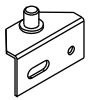

**x 4**

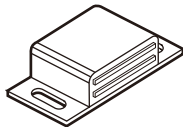

**x 2**

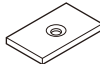

**x 2**

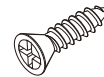

F+5x1/2"

**x 2**



M3.5x13mm.

**x 12**

# ASSEMBLY

-BODY SET

**1.**

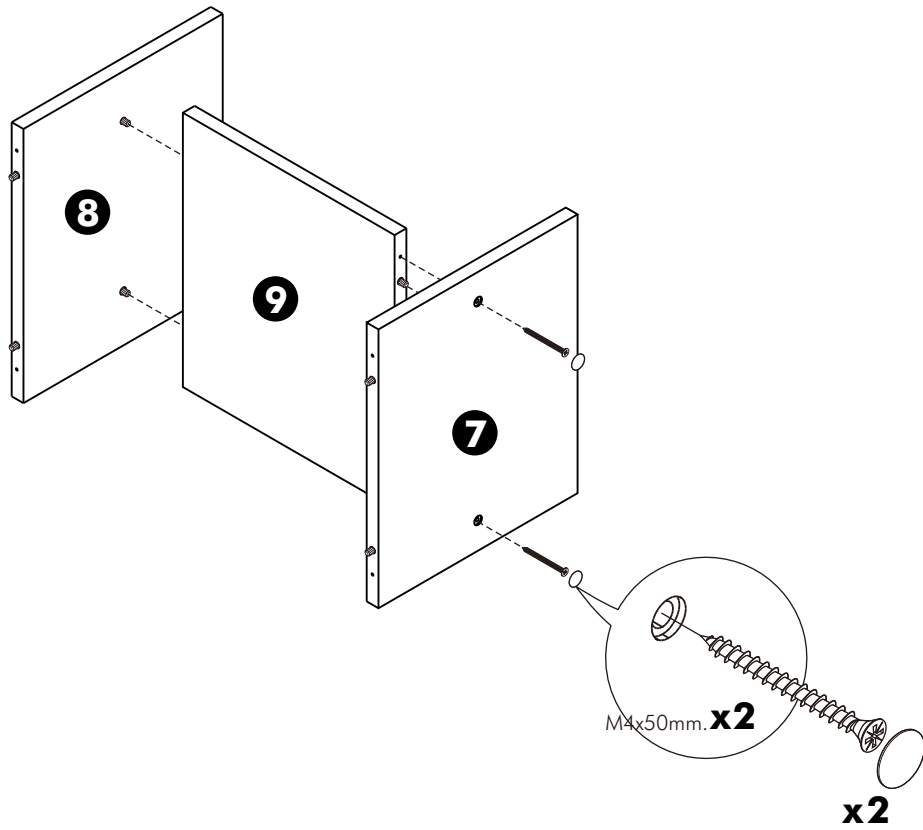

**2.**

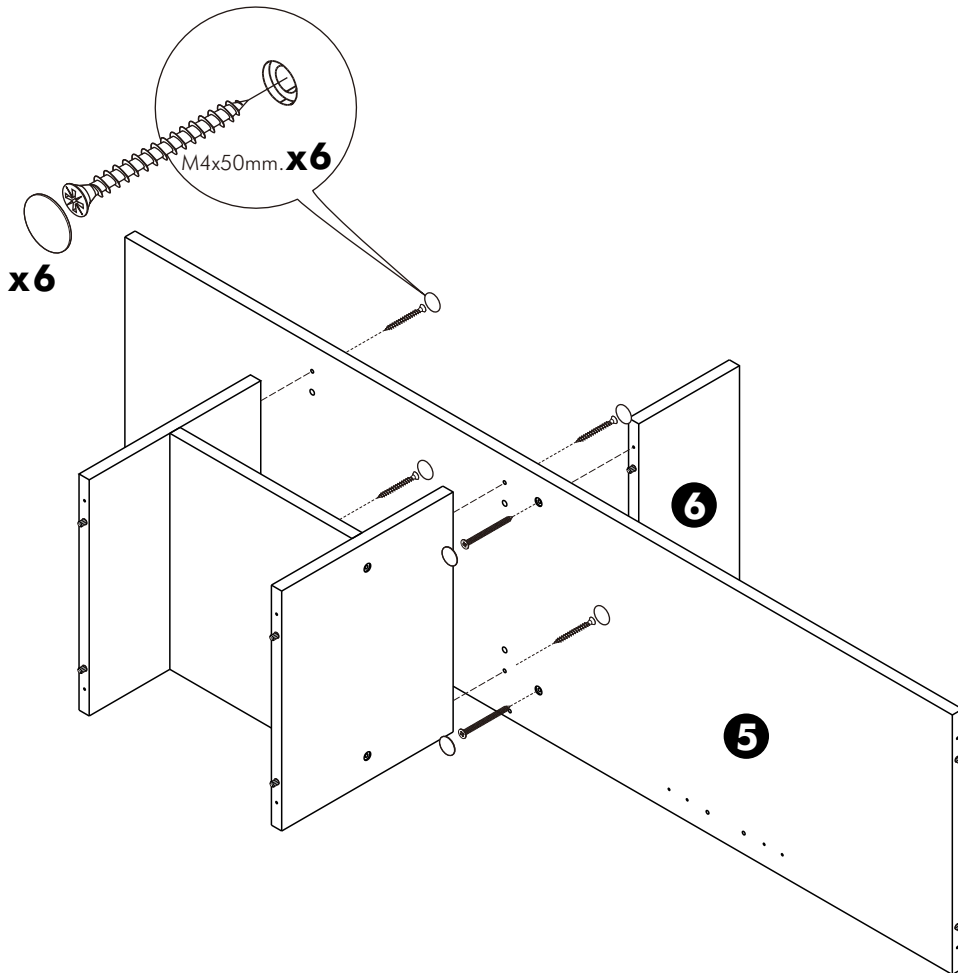

**3.**

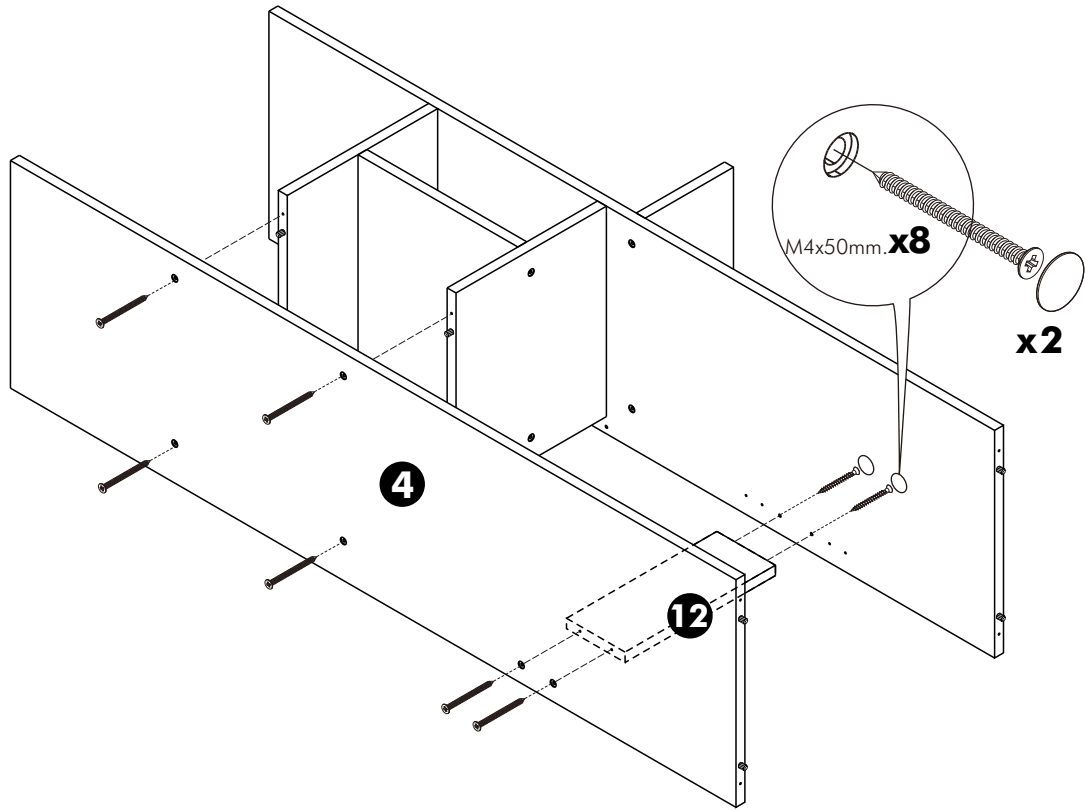

**4.**

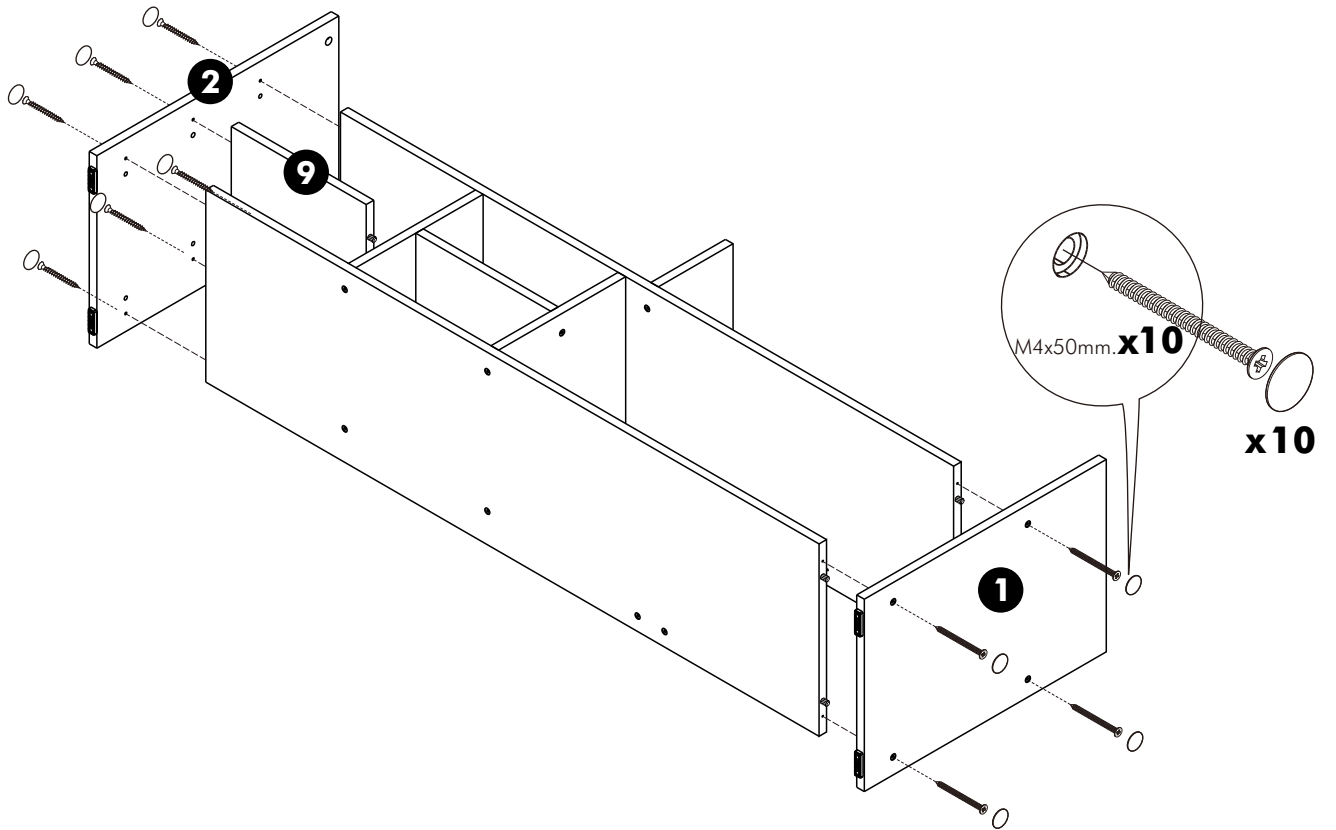

**5.**

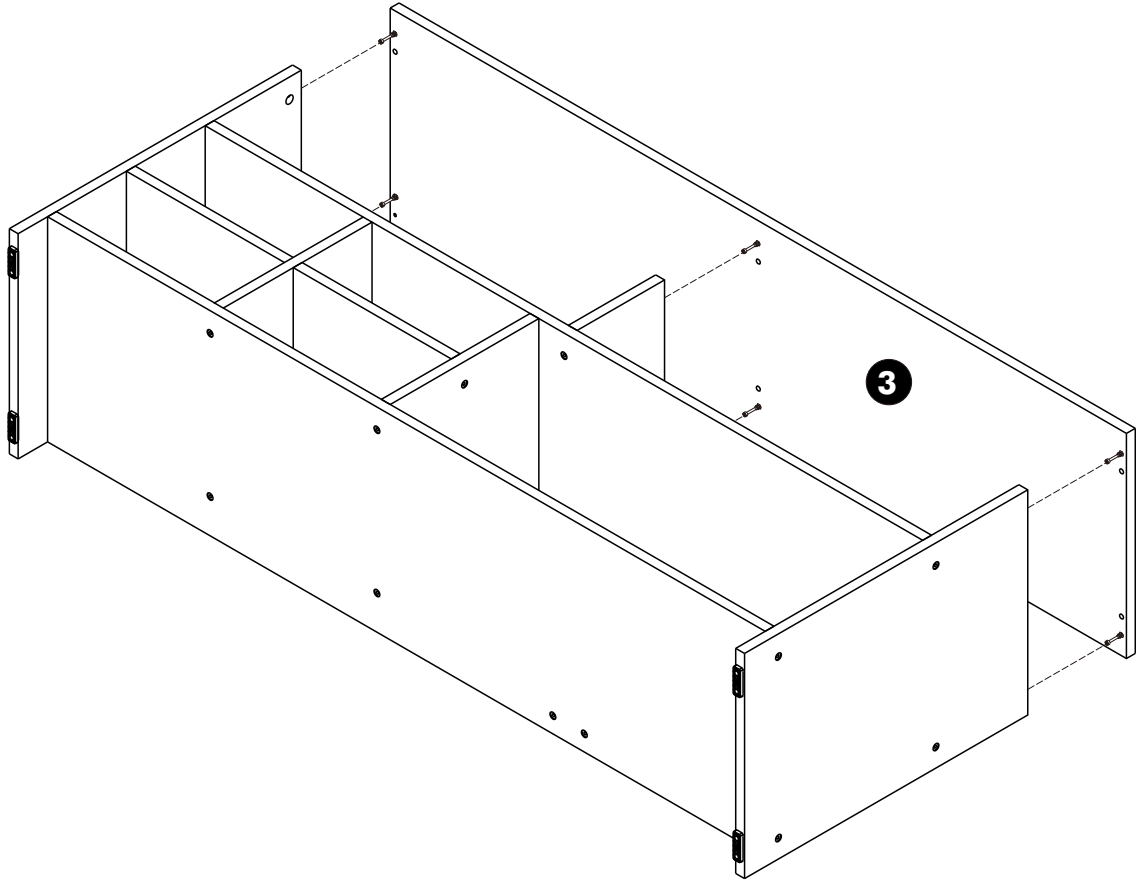

**6.**

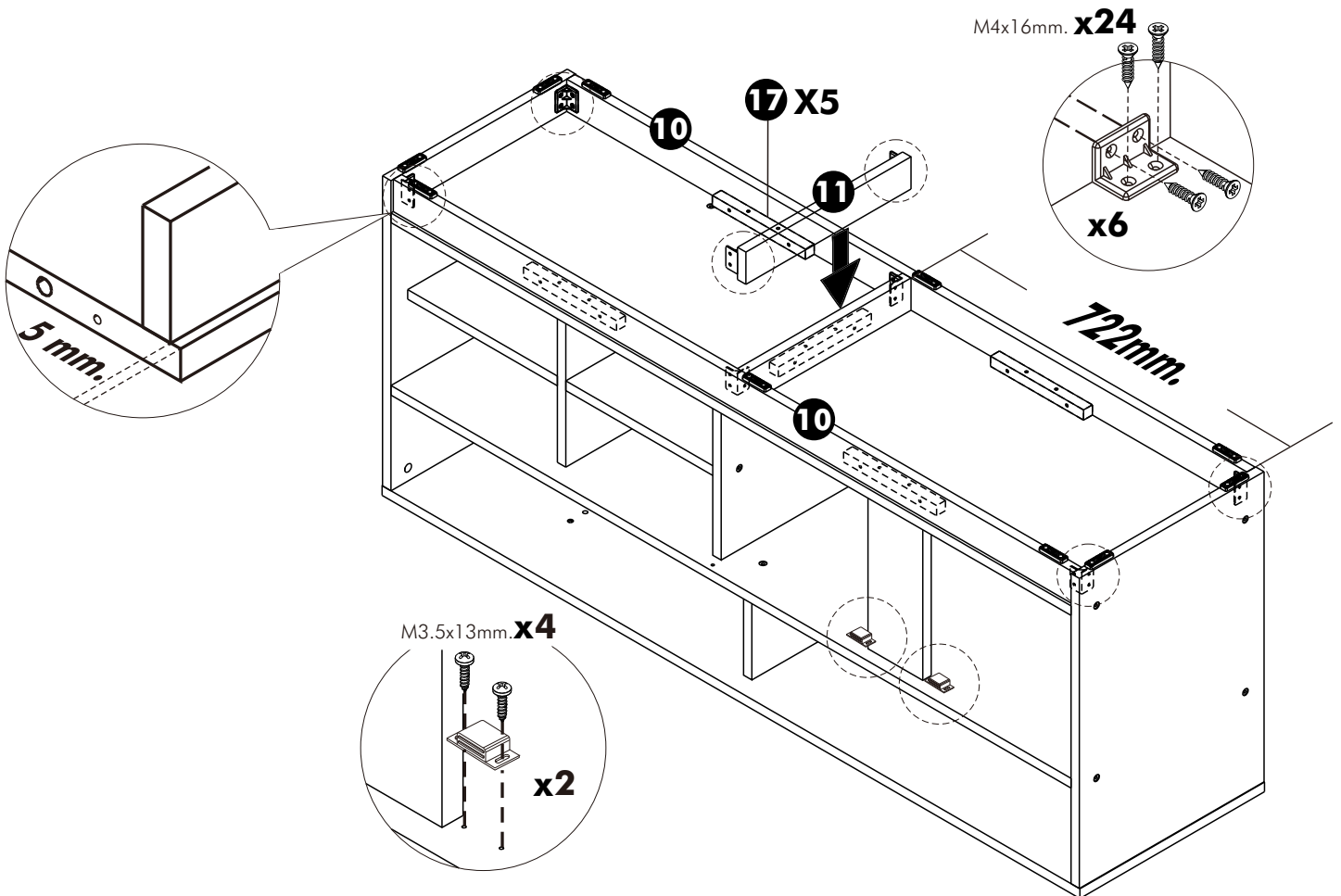

**7.**

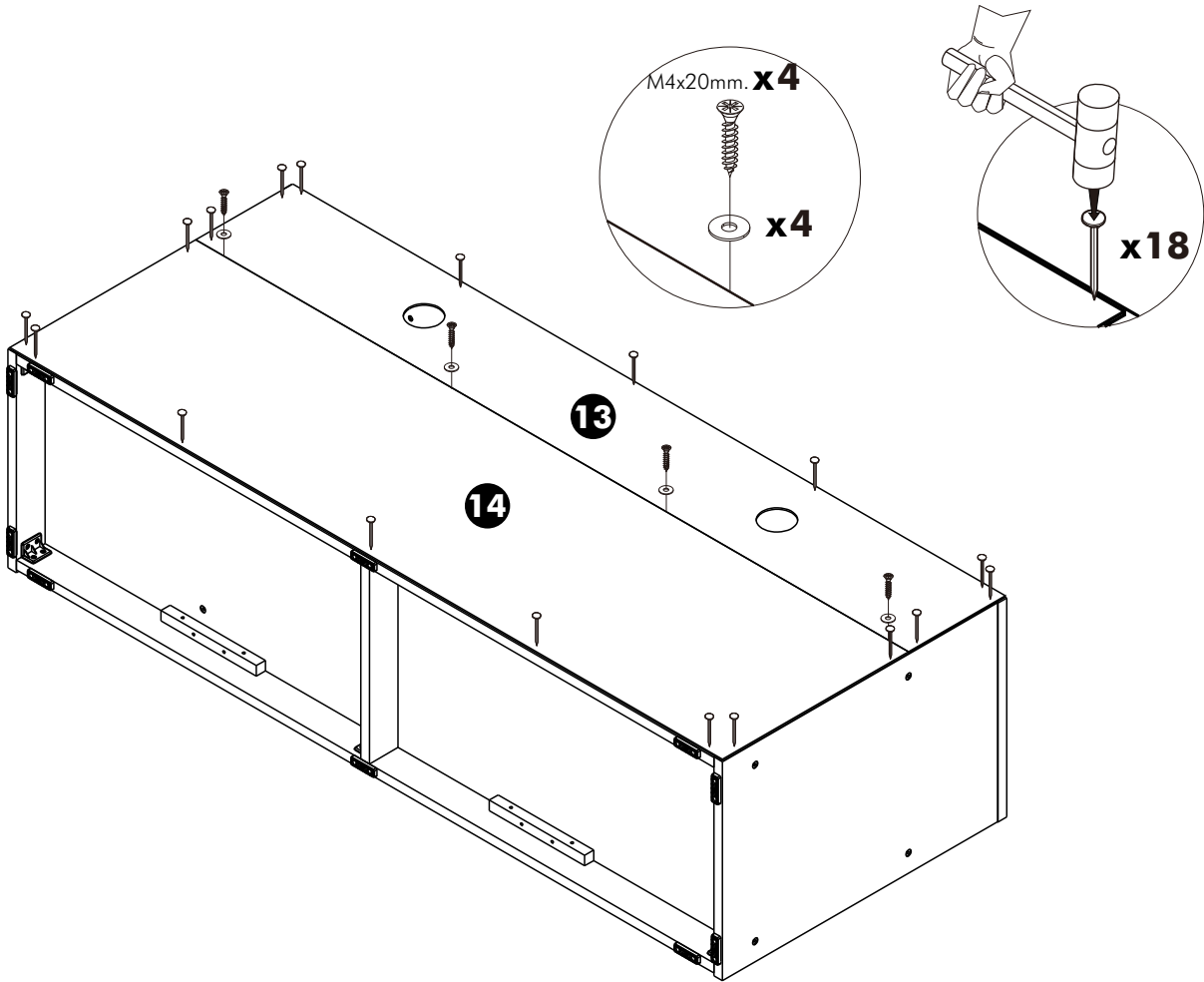

**8.**

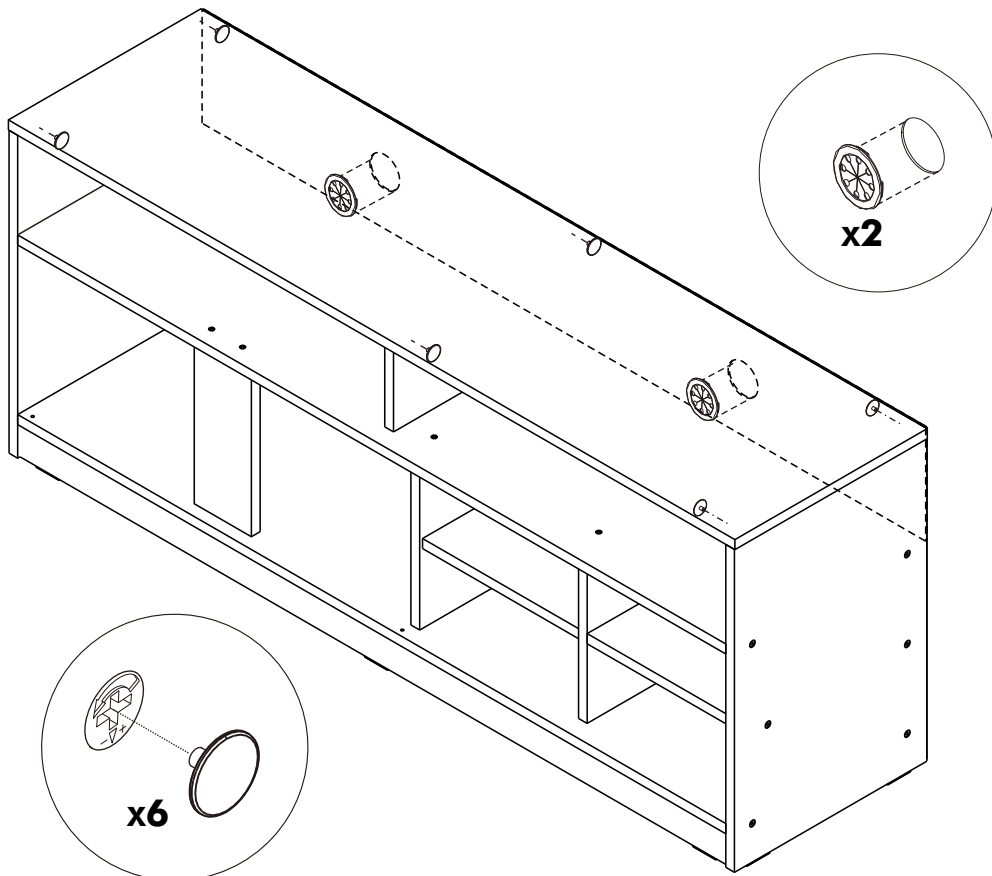

9.

