

# GRUFF

**Glass coffee table 120cm.**

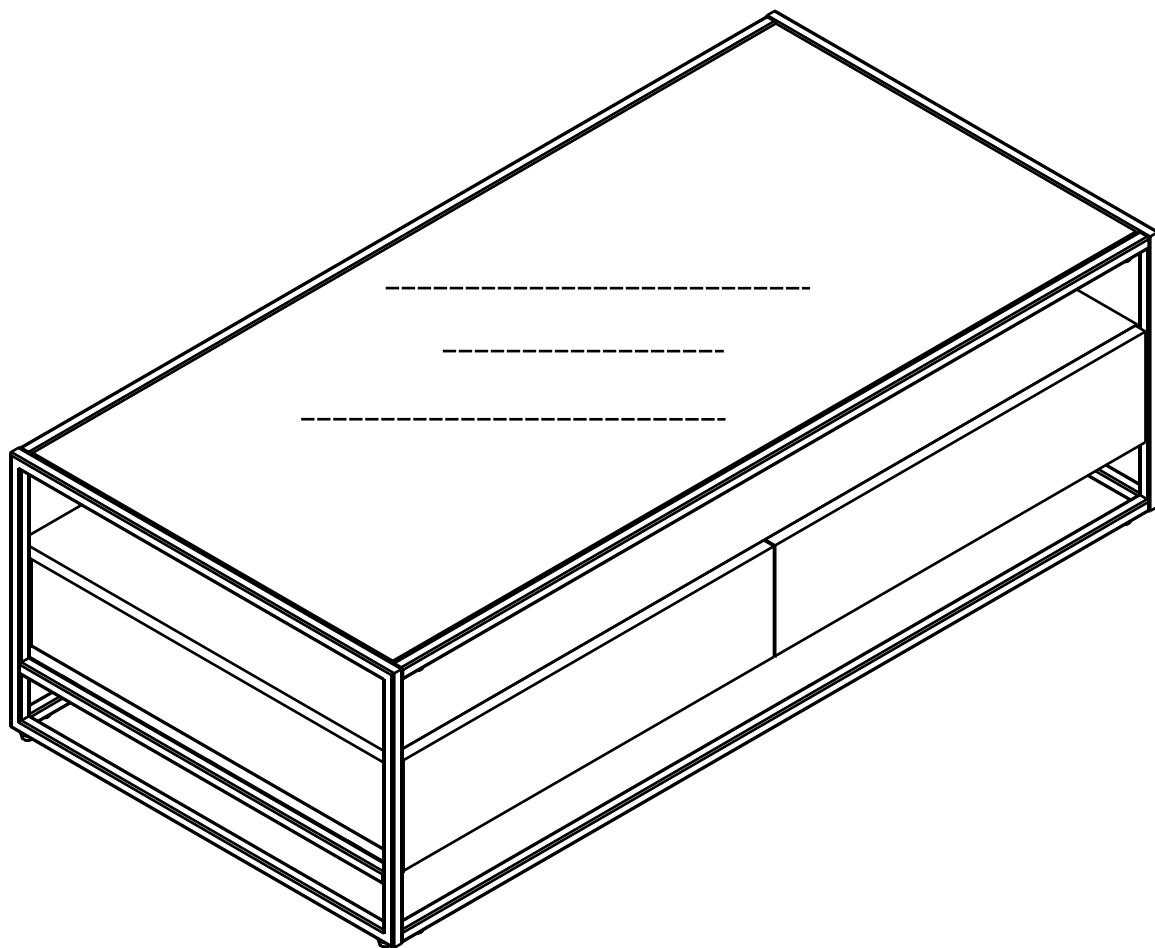

# CONNECT SYSTEM

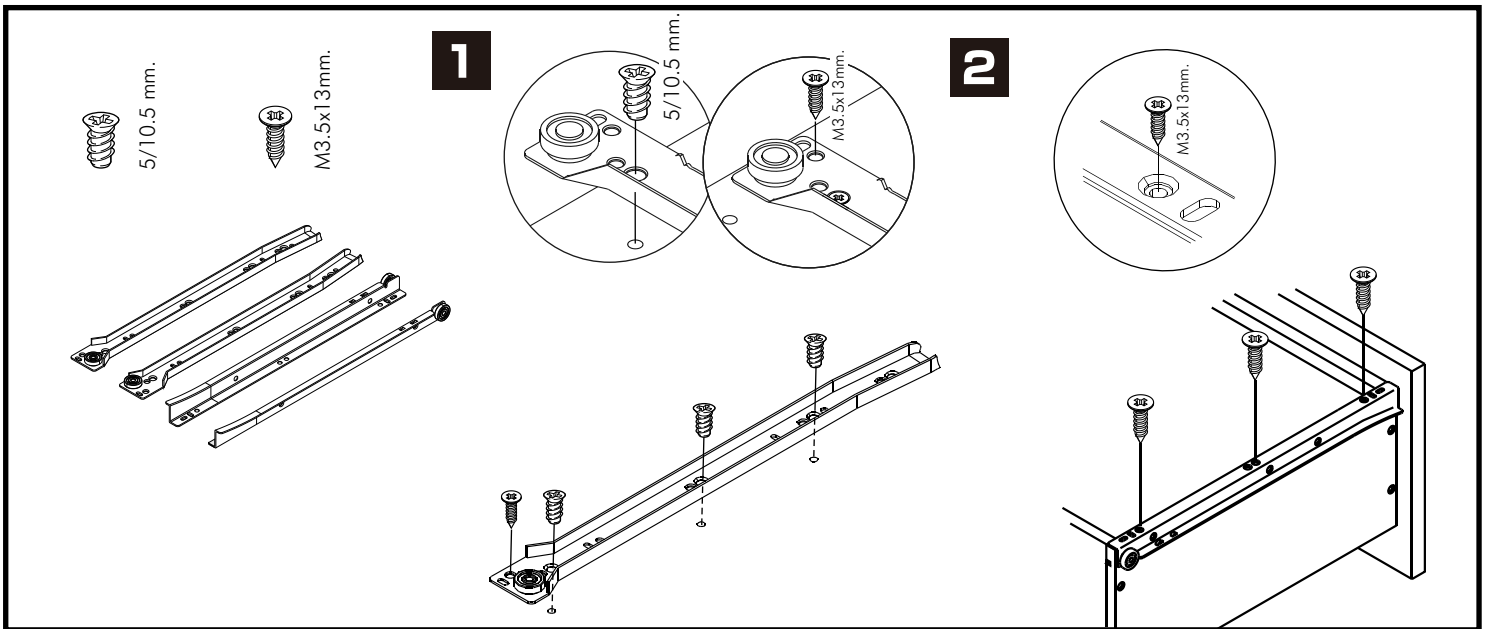

# HARDWARE

## -BODY SET

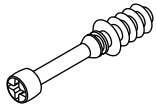

**X8**

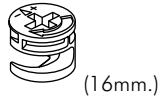

**X6**

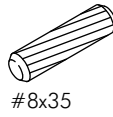

**X18**

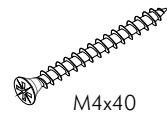

**X8**



**X7**



**X4**



**X10**



**X10**



**X8**



**X2**

## -DRAWER SET

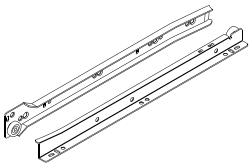

**X2**

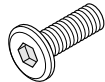

#TFL4 M6x23

**X10**

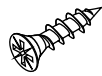

#F+M3.5x13

**X16**

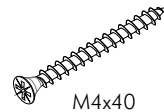

**X20**



**X1**



M5x10.5

**X12**

**1.**

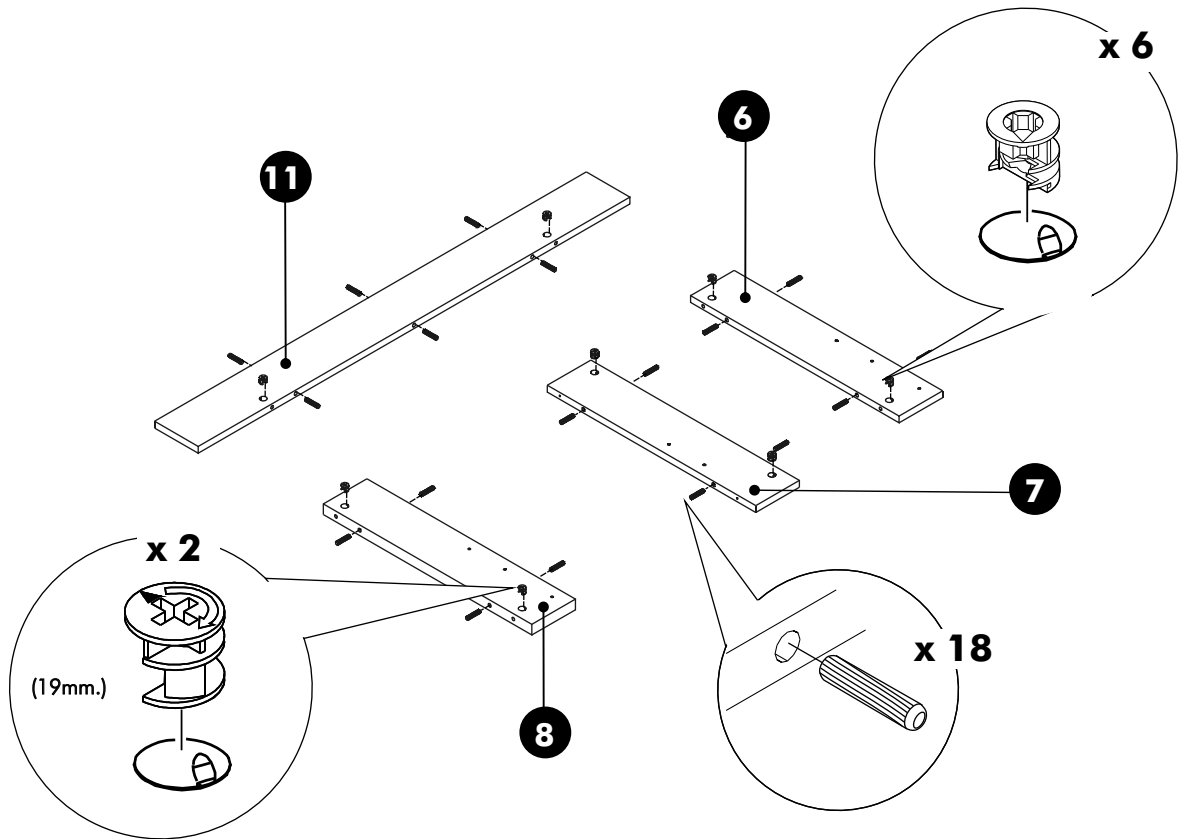

**2.**

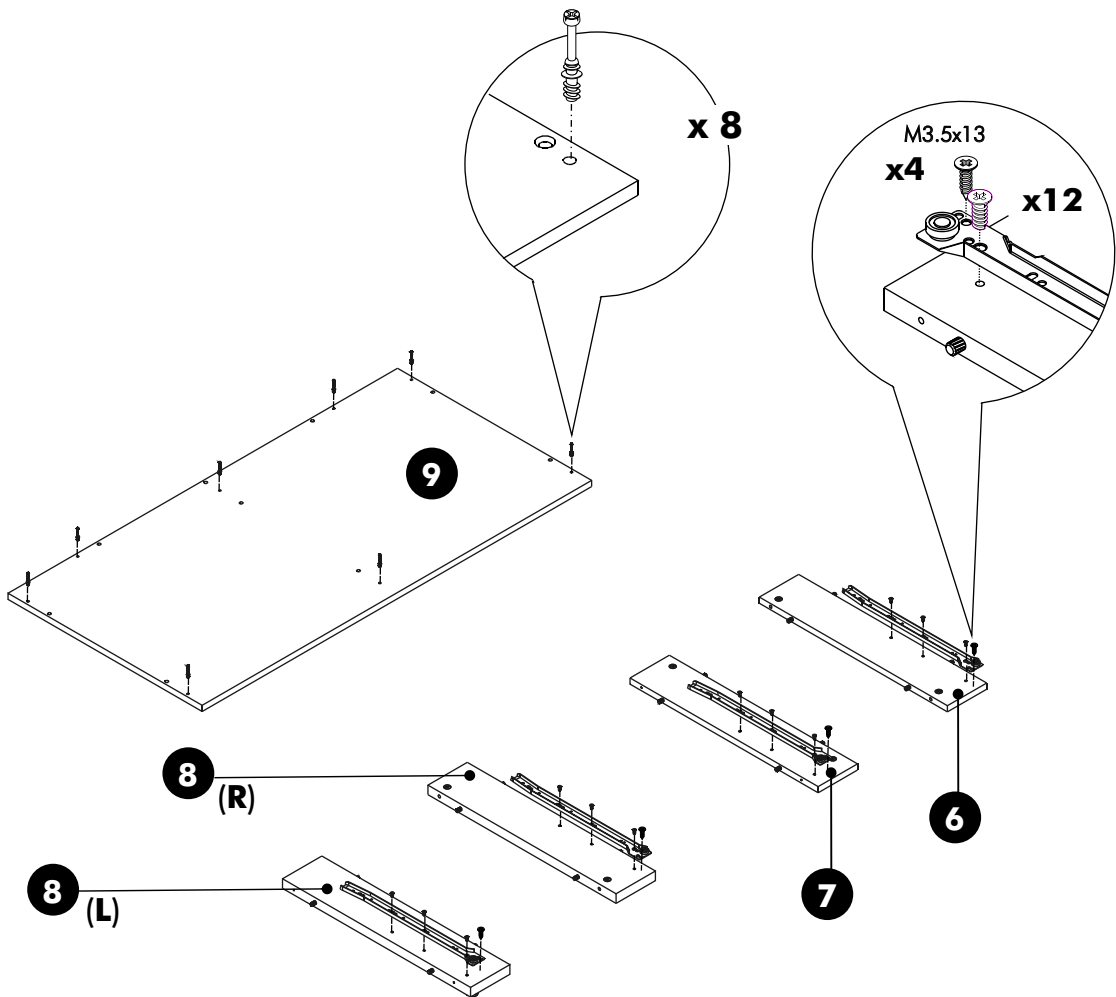

**3.**

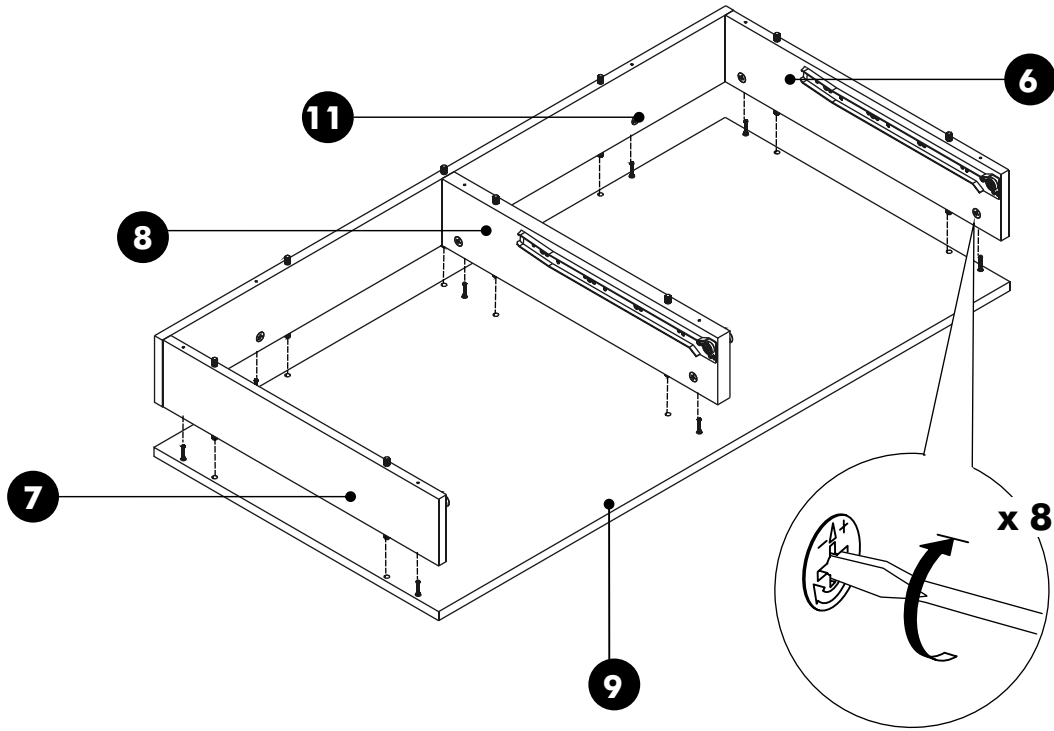

**4.**

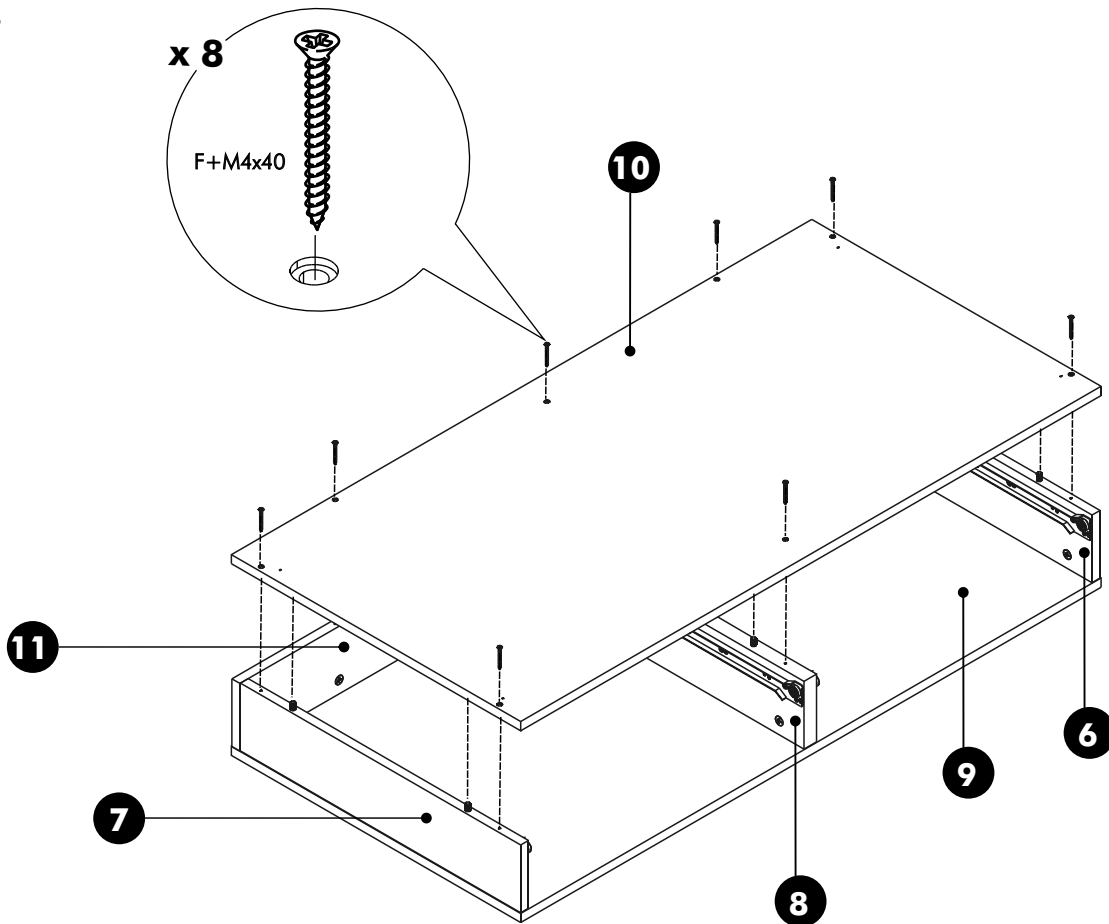

**5.**

NOTE: Do not over tighten cam screws.

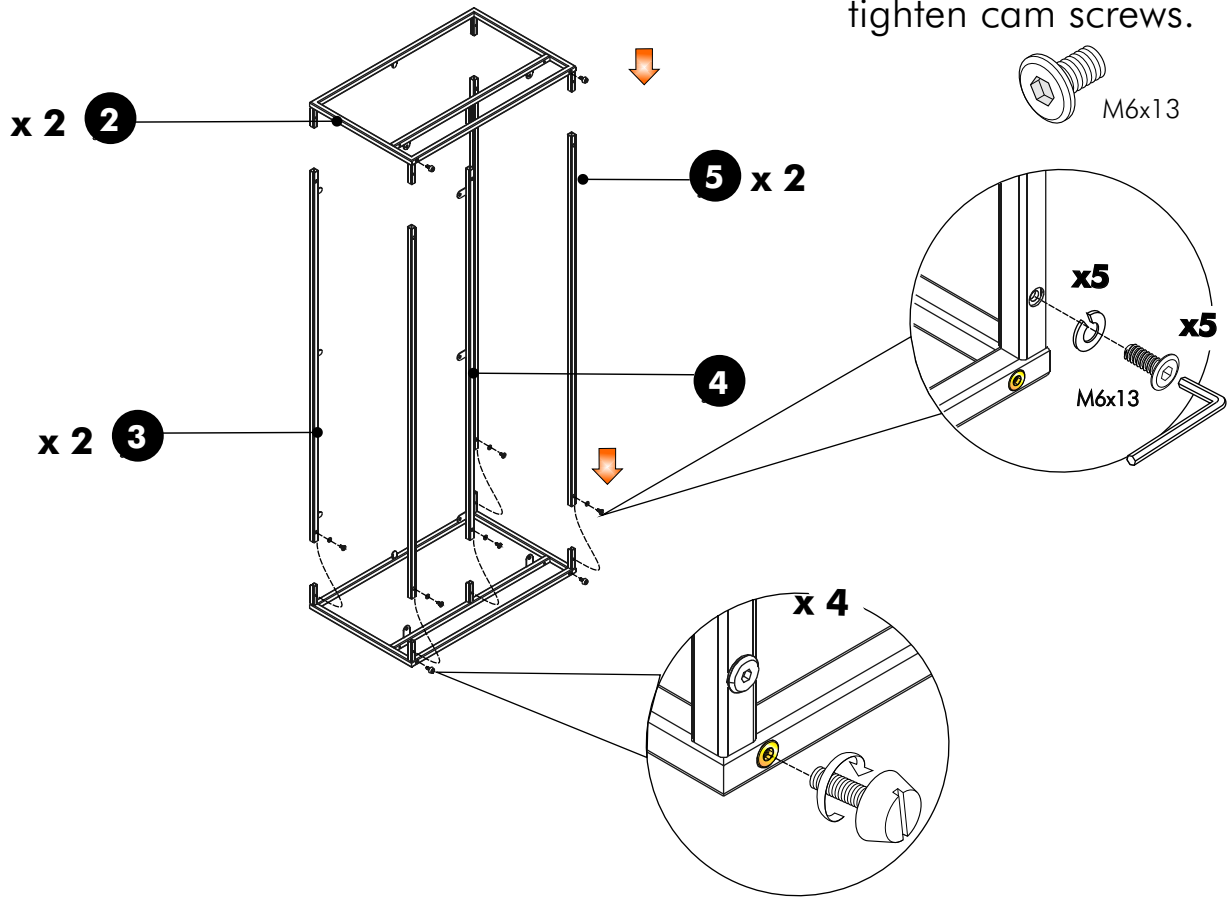

**6.**

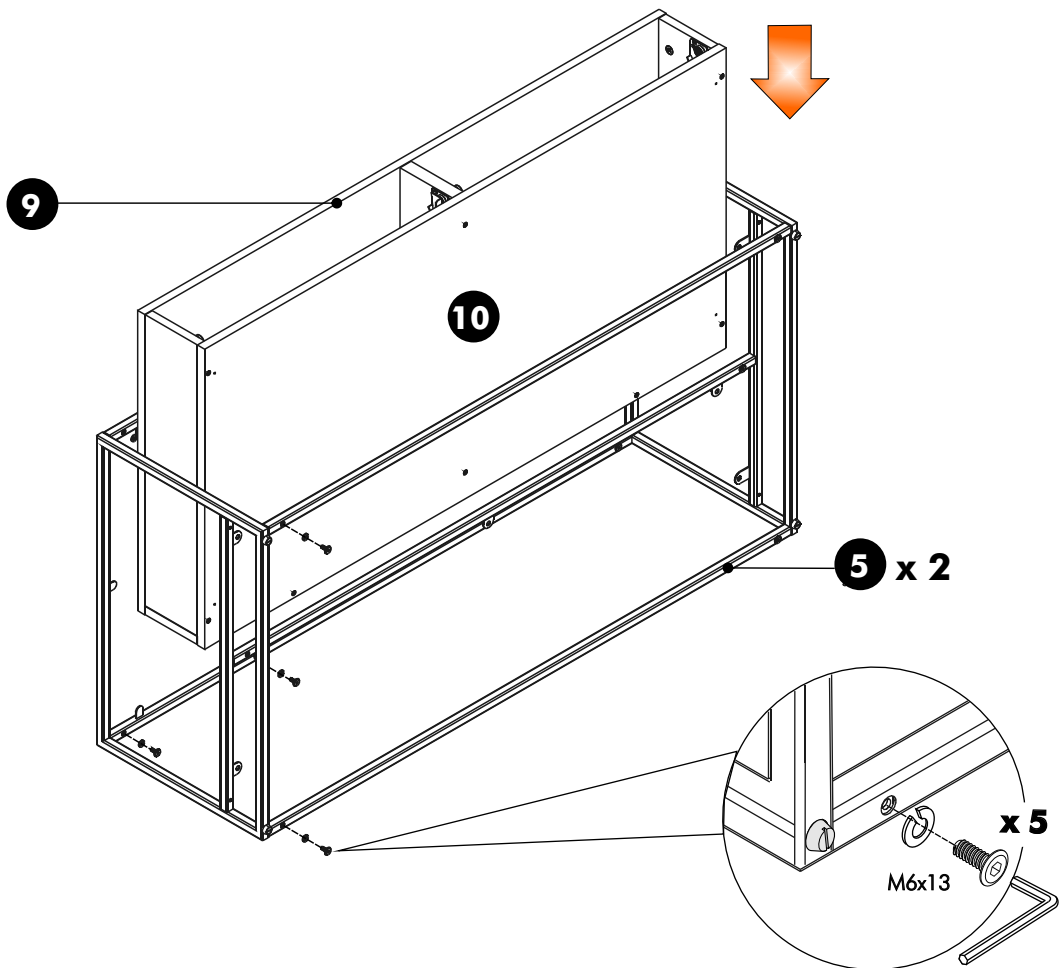

**7.**

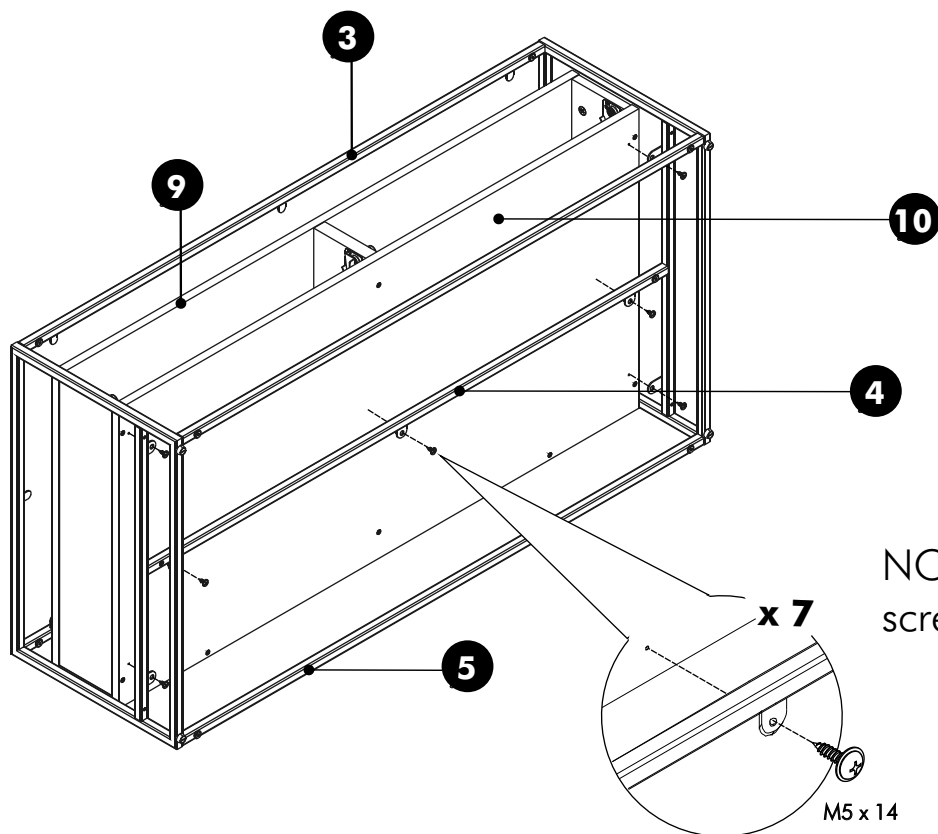

NOTE: retighten screw

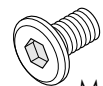

M6x13

**8.**

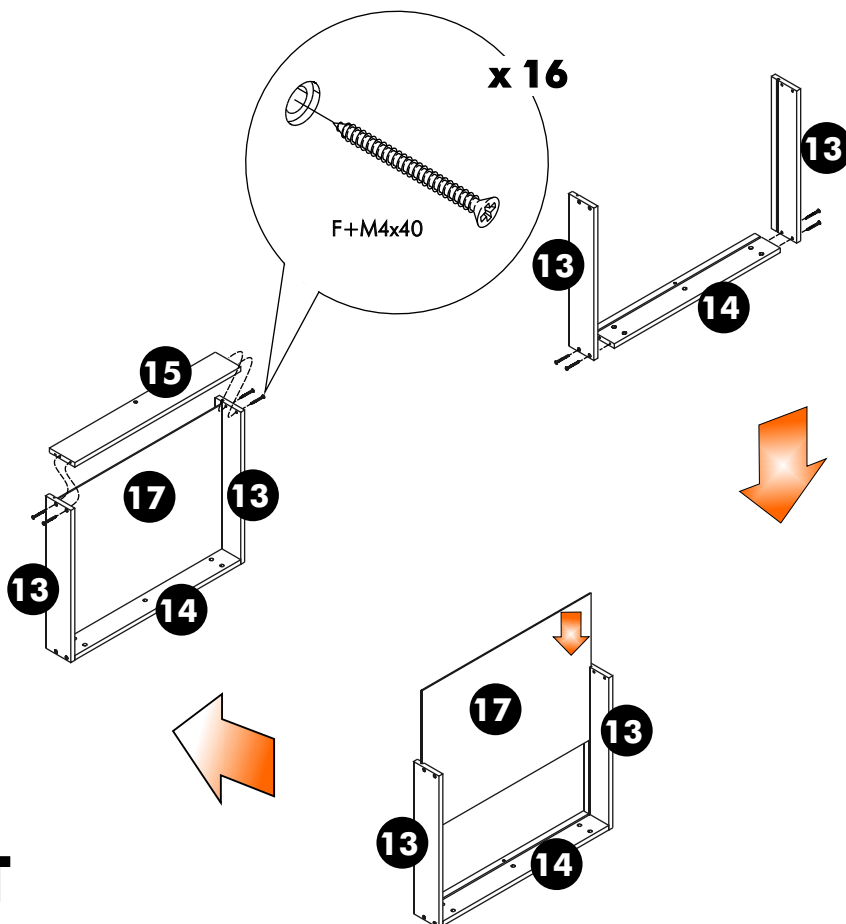

**2 SET**

9.

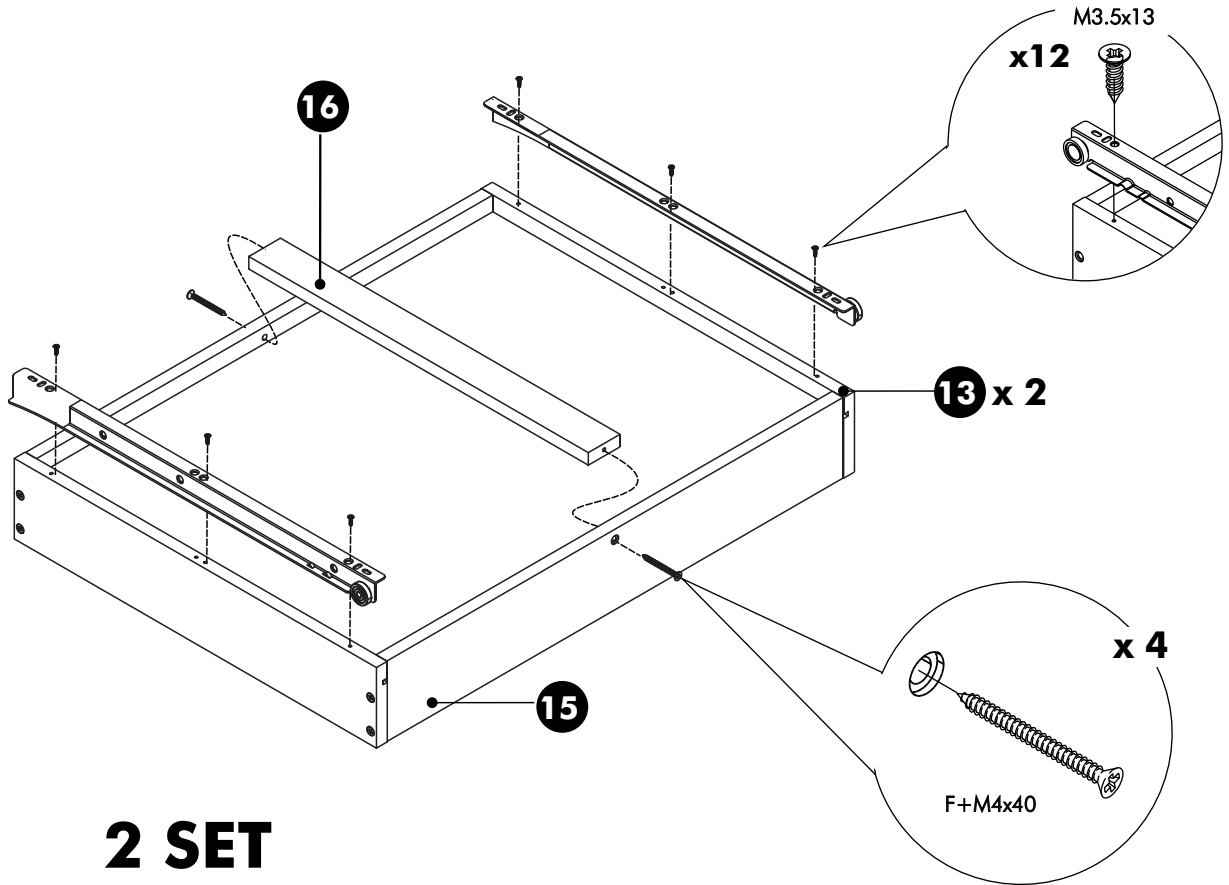

10.

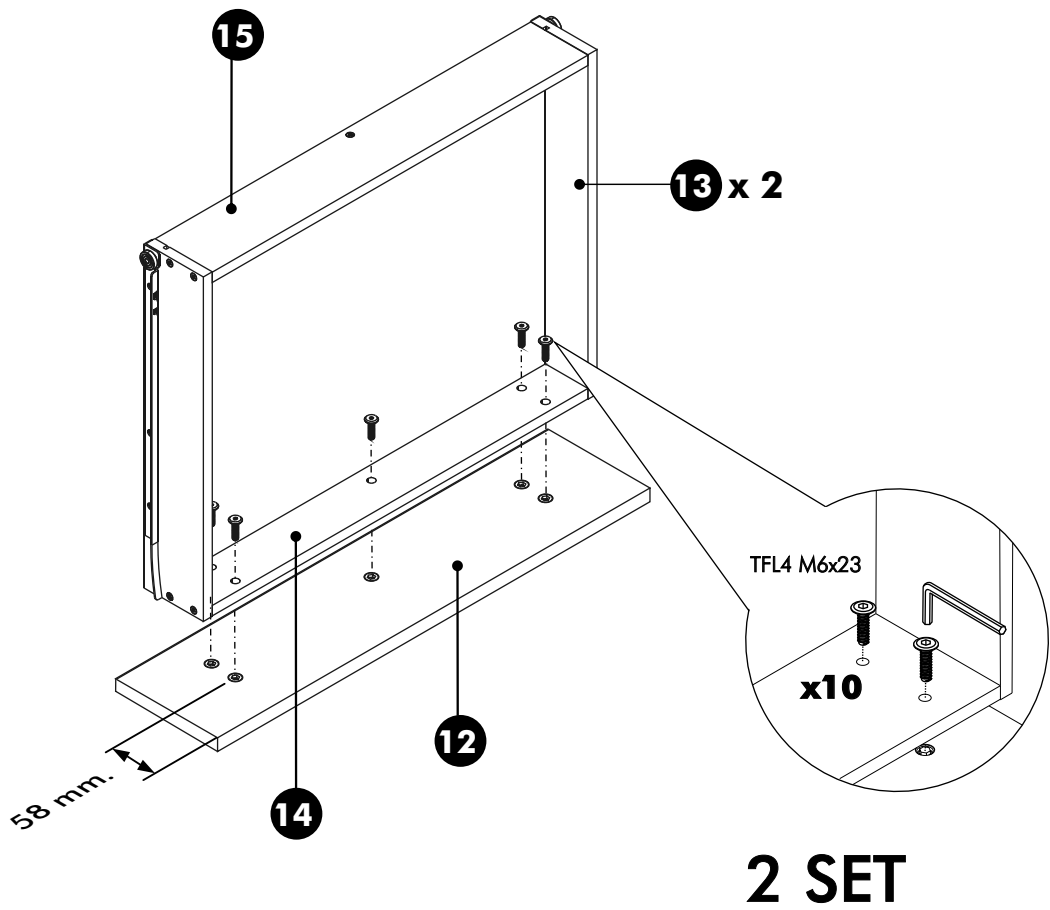

11.

