

VECTRA

Desk 100 cm.

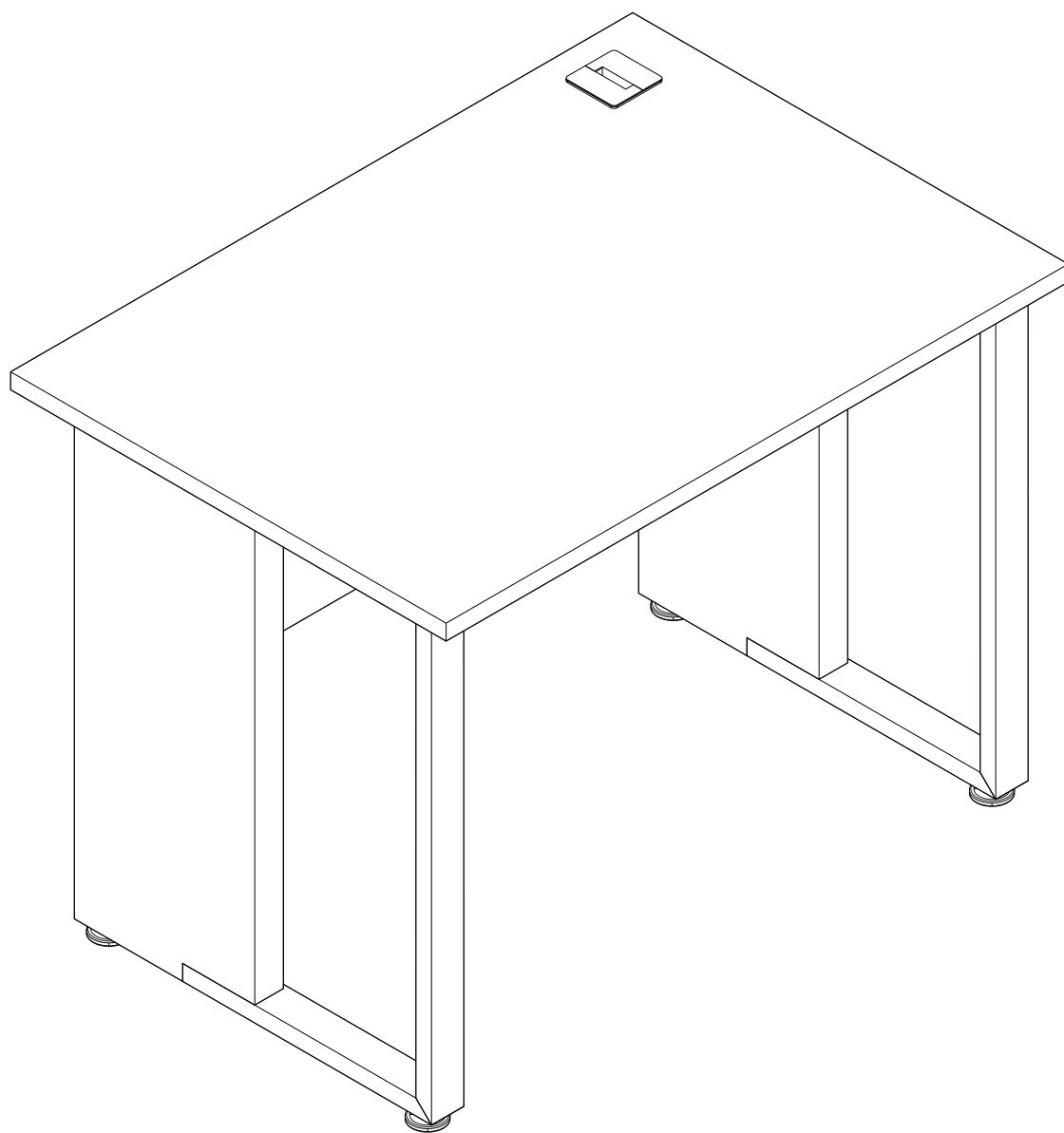

CONNECT SYSTEM

1

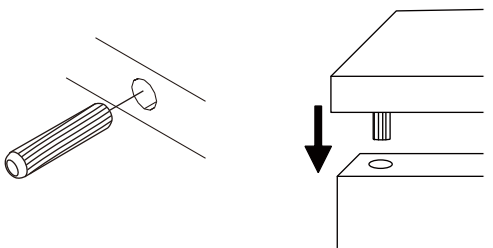

2

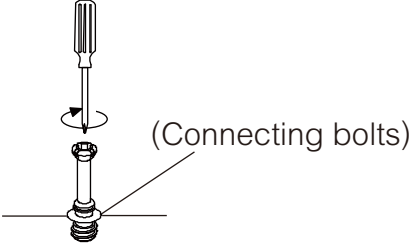





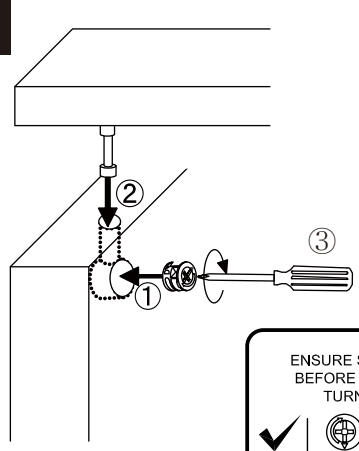

(Connecting bolts)

3



WHEN FITTING CAMS
ENSURE STARTING POSITION IS CORRECT
BEFORE YOU INSERT CONNECTING BOLT
TURN CLOCKWISE UNTIL SECURE

✓				✗
				
	CORRECT	WRONG		

HARDWARE

-BODY SET

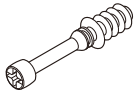

x 9



19mm.

x 9

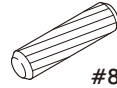

#8x35

x 10



x 9

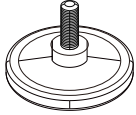

x 4



M4x16mm.

x 8



F+DWS M5.5x50mm.

x 4

-PART

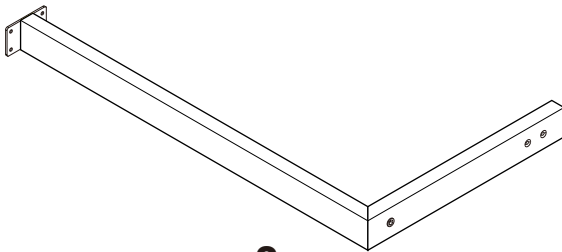

x 2

ASSEMBLY

-BODY SET

1.

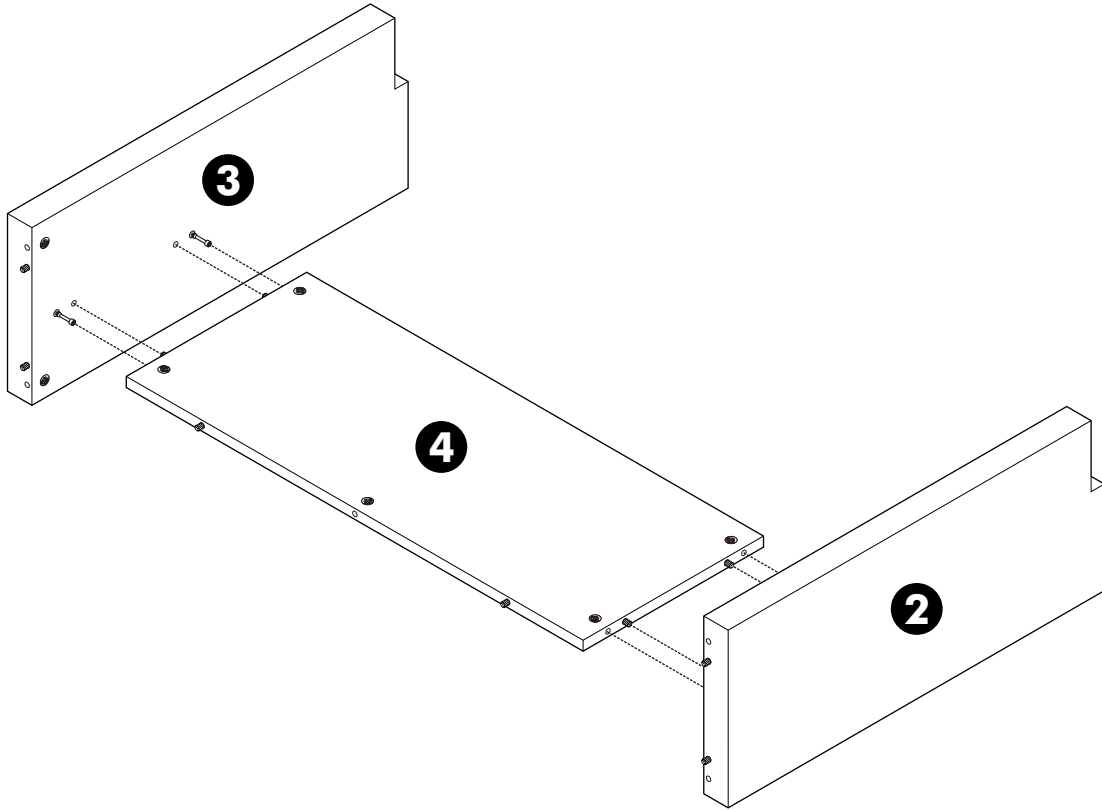

2.

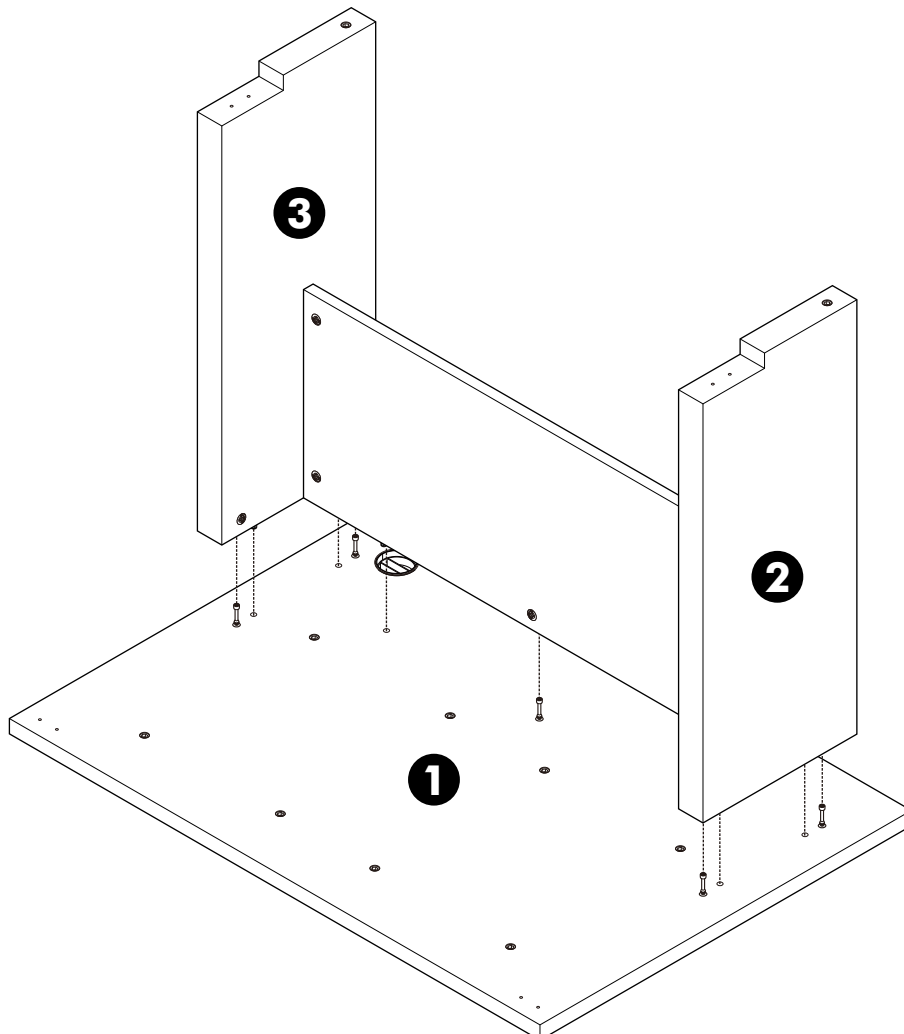

3.

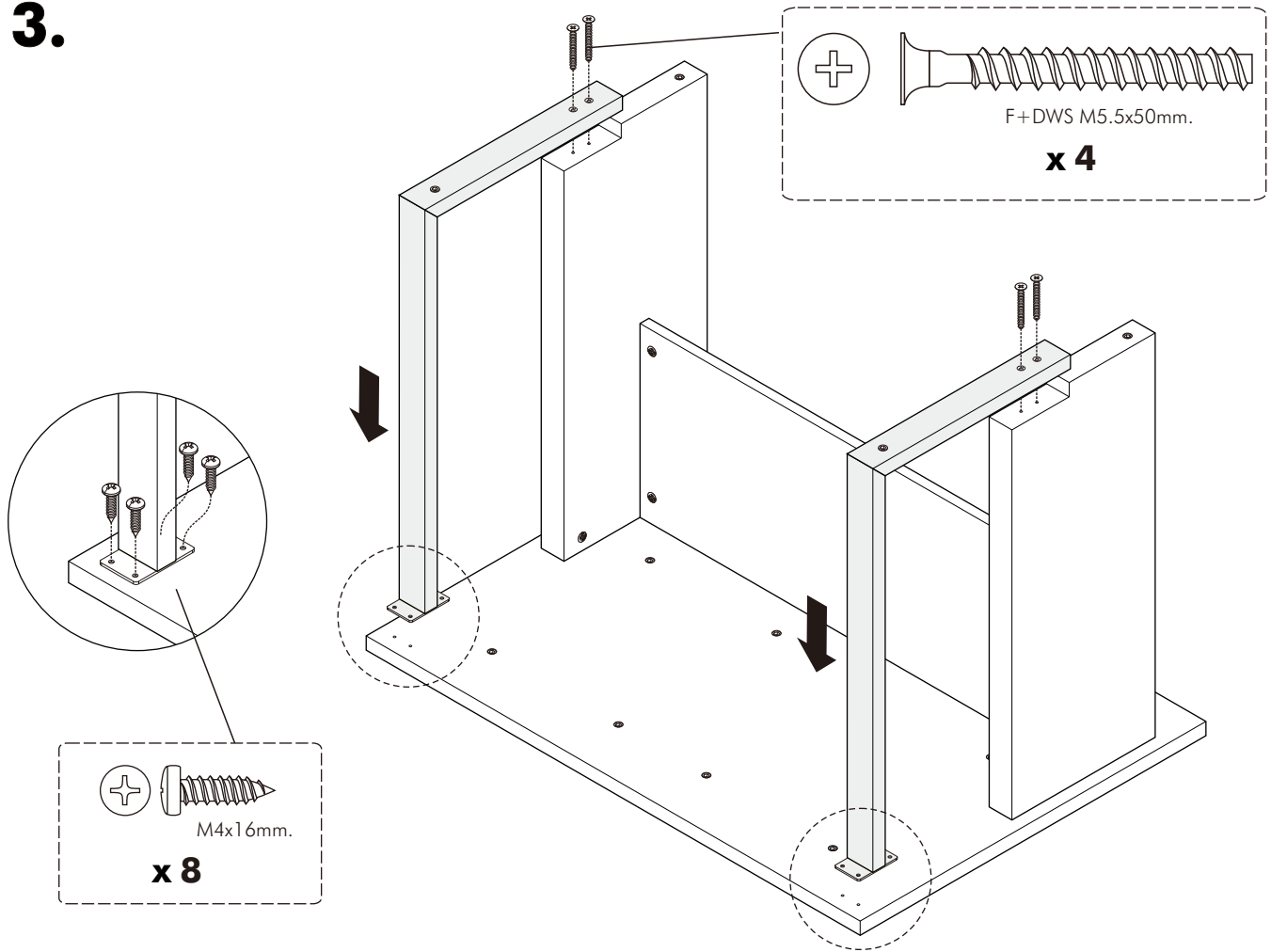

4.

