

BUONA-P

Night Table 40 cm.

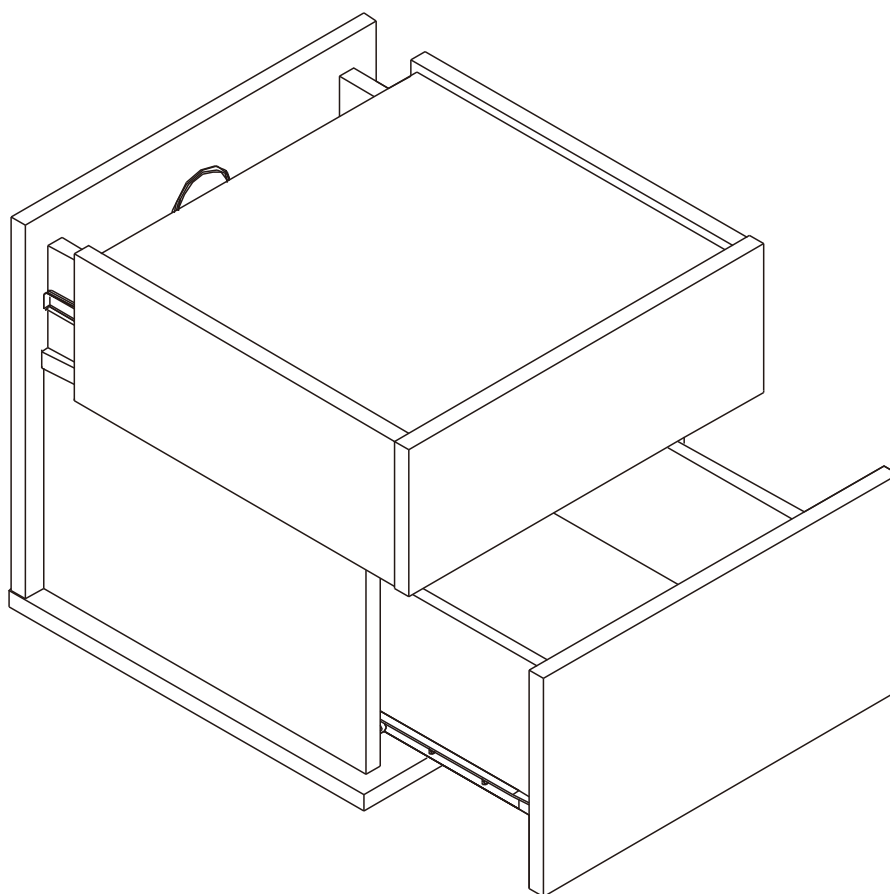

CONNECT SYSTEM

1

3

2

(Connecting bolts)

WHEN FITTING CAMS
ENSURE STARTING POSITION IS CORRECT
BEFORE YOU INSERT CONNECTING BOLT
TURN CLOCKWISE UNTIL SECURE

✓

↑
CORRECT

✗

↓ ↑
WRONG

1 Pc.

EQ EQ

≤ 190mm.

40mm. 40mm.

2 Pcs.

≥ 191-850mm.

100mm. EQ EQ 100mm.

3 Pcs.

850-2000mm.

100mm. EQ EQ EQ 100mm.

4 Pcs.

> 2001mm.

M4x16mm.

OUT

IN

i

40mm.

EQ

M3.5x13mm.

1

2

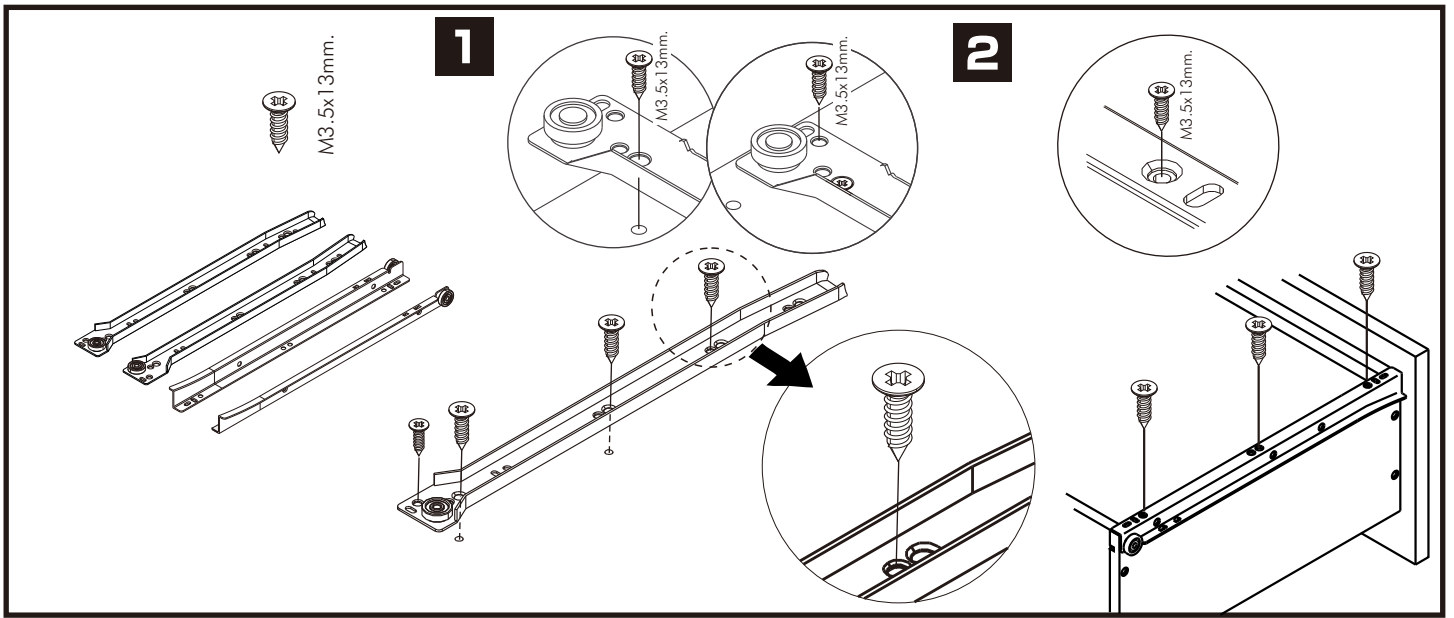

HARDWARE

-BODY SET

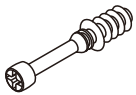

x 14



x 14

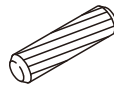

x 30



M4x40mm.

x 20



x 1

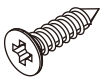

M4x16mm.

x 8

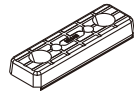

x 4

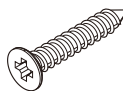

M4x30mm.

x 8

-DRAWER SET

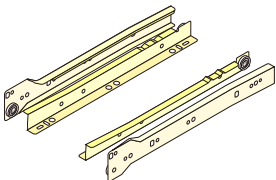

x 1

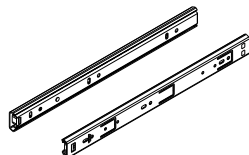

x 1



M3.5x13mm.

x 26

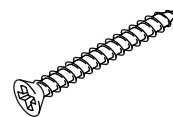

M4x40mm.

x 8



M6x23mm.

x 4



x 1

ASSEMBLY

-BODY SET

1.

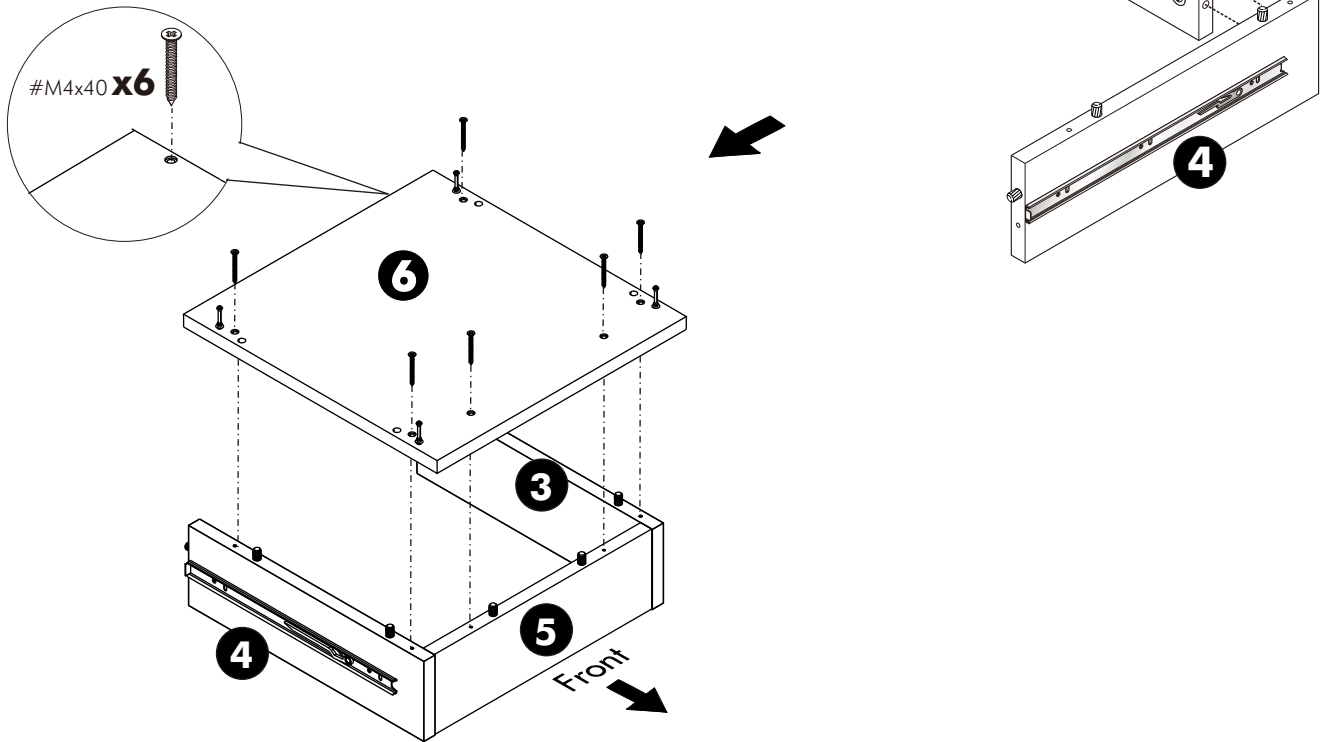

2.

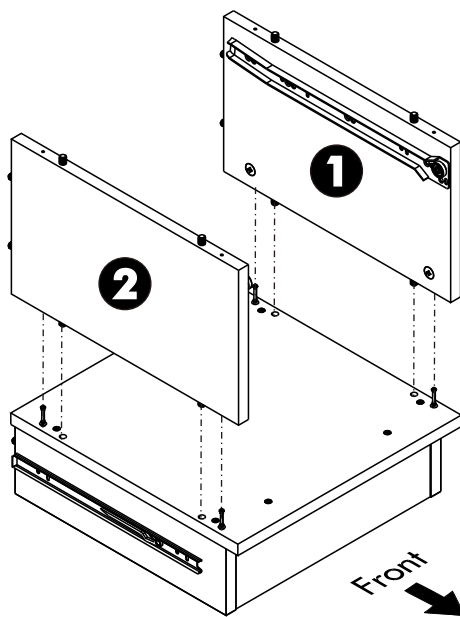

3.

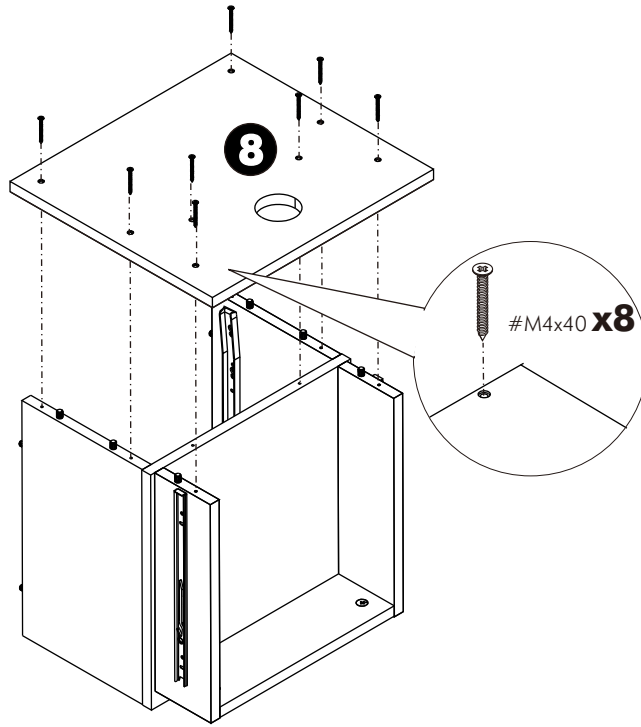

4.

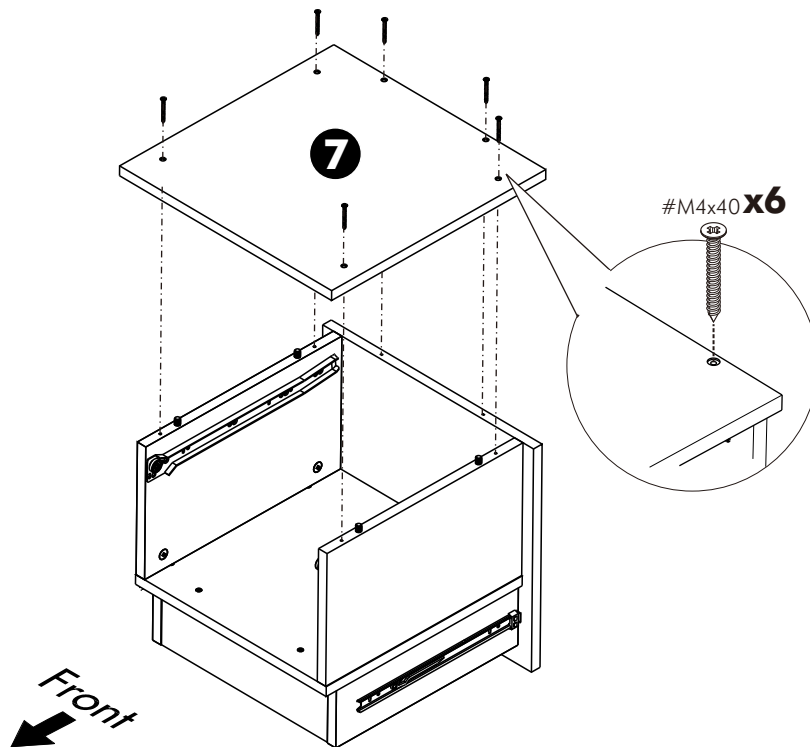

5.

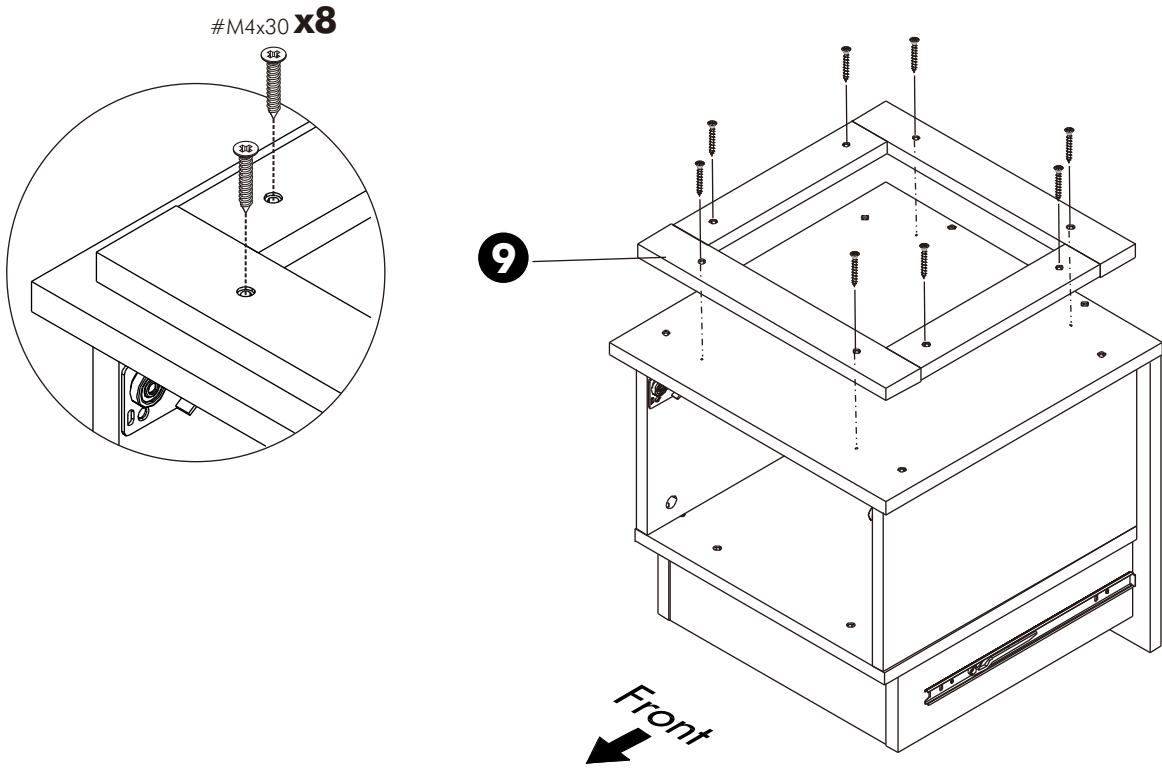

ASSEMBLY

-DRAWER SET

6.

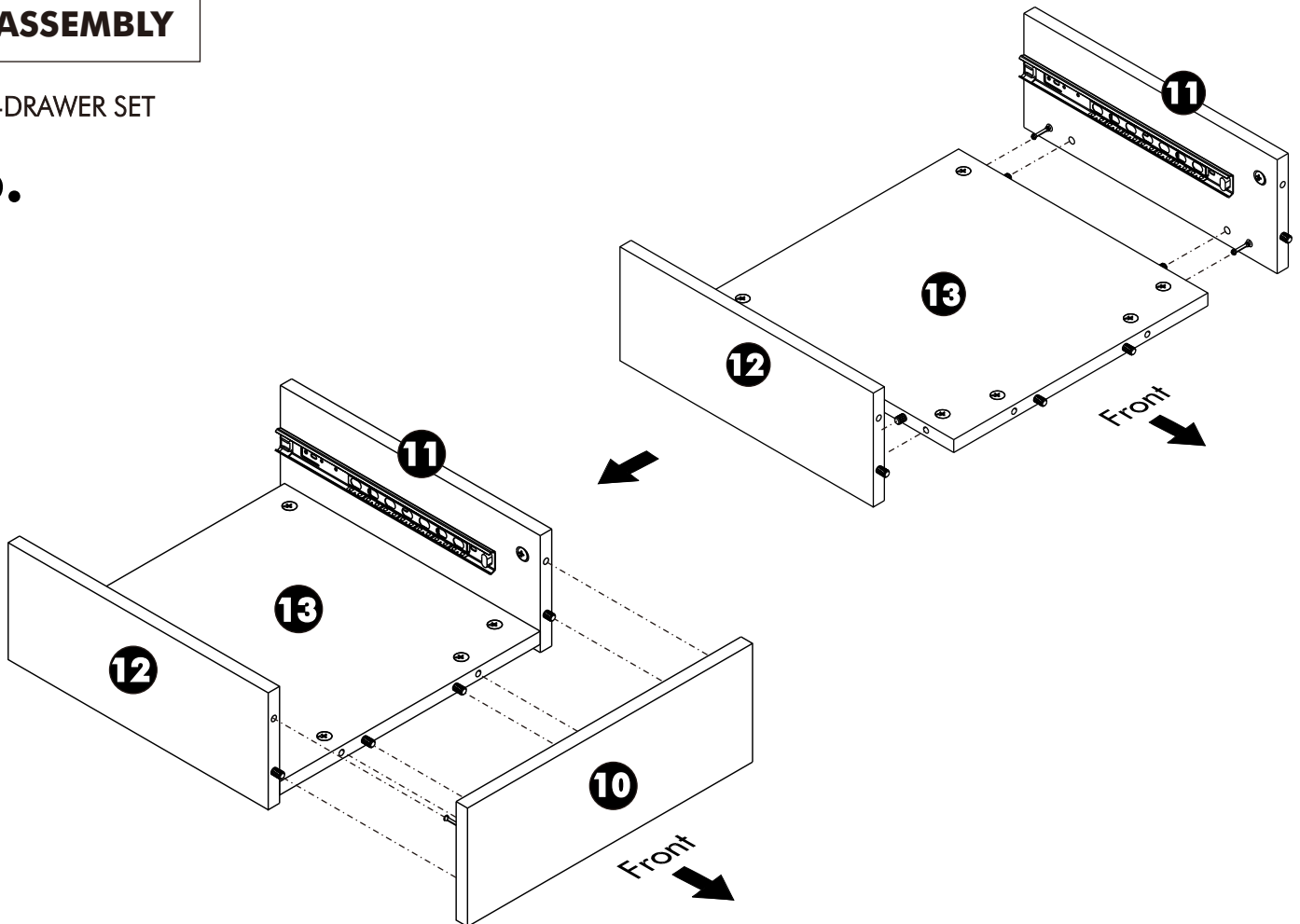

7.

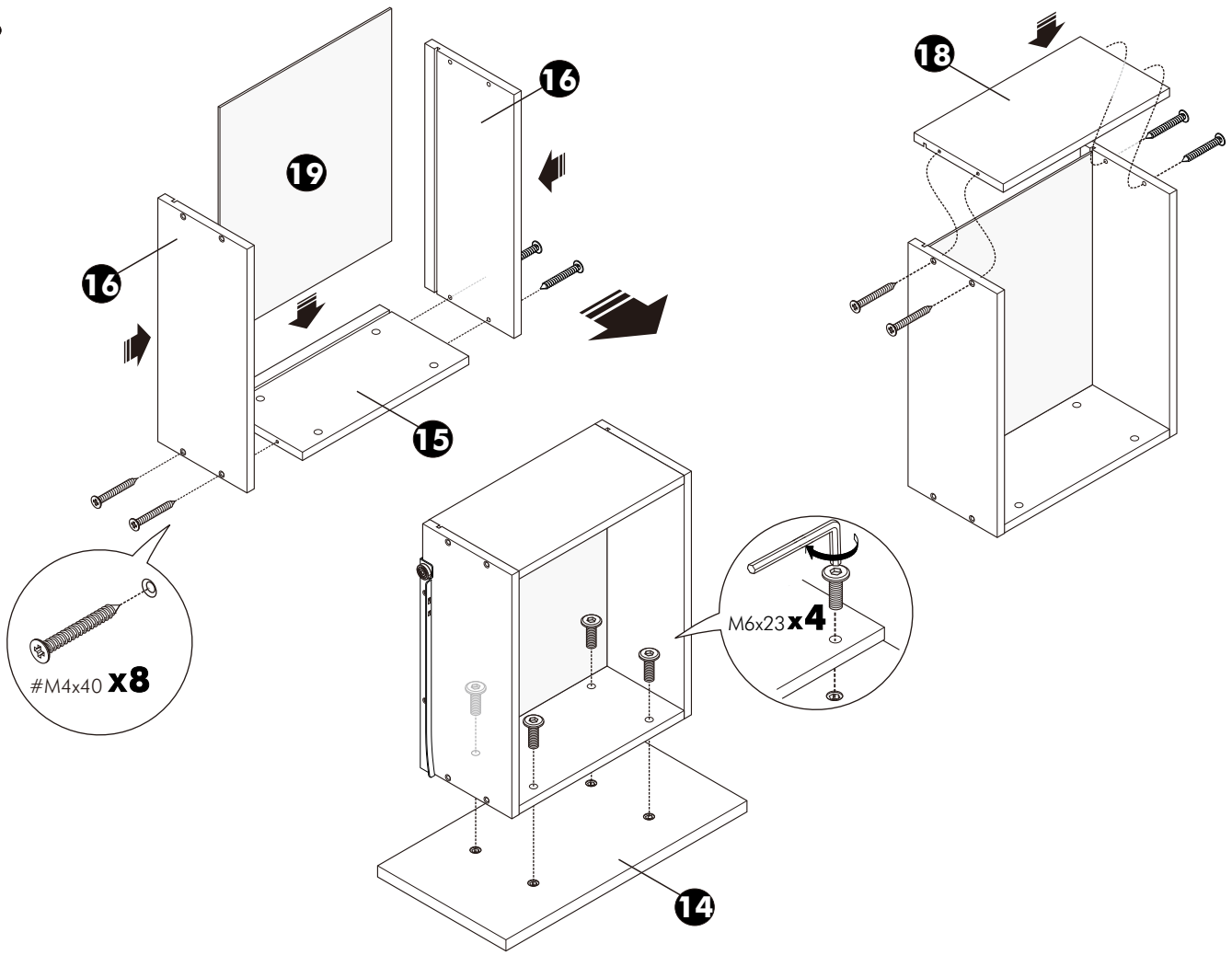

8.

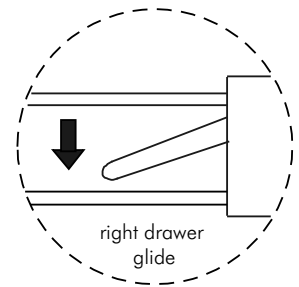
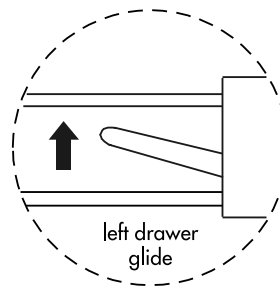
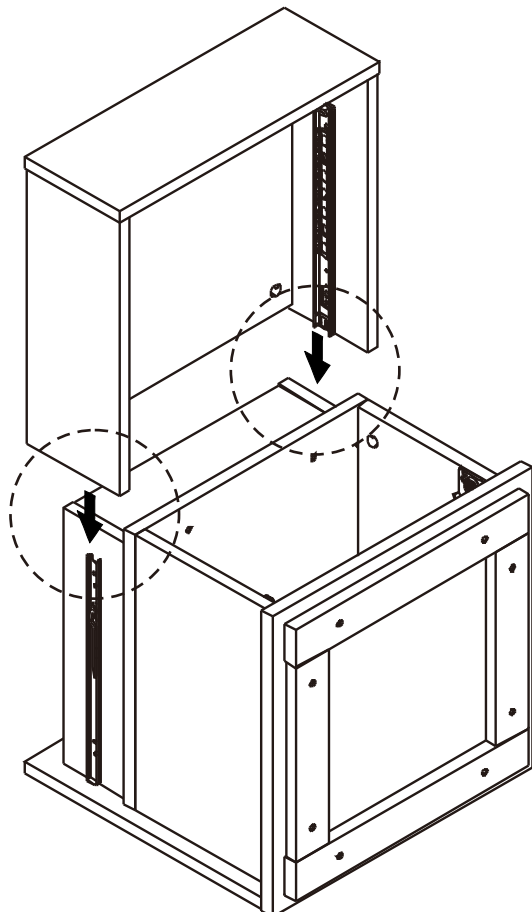

A) Attach drawer assembly to assembled unit:

Fit drawer glides of drawer assembly into corresponding drawer glides of unit. Push drawer all the way into the assembled unit. Test the drawer by opening and closing a couple of times to ensure it is attached. Assembly is now complete.

B) To remove drawer assembly from assembled unit:

Fully extend drawer assembly from unit. Locate plastic tabs on left and right drawer glides. With even pressure, simultaneously lift the left tab and push down the right tab and pull the drawer from the assembled unit.

9.

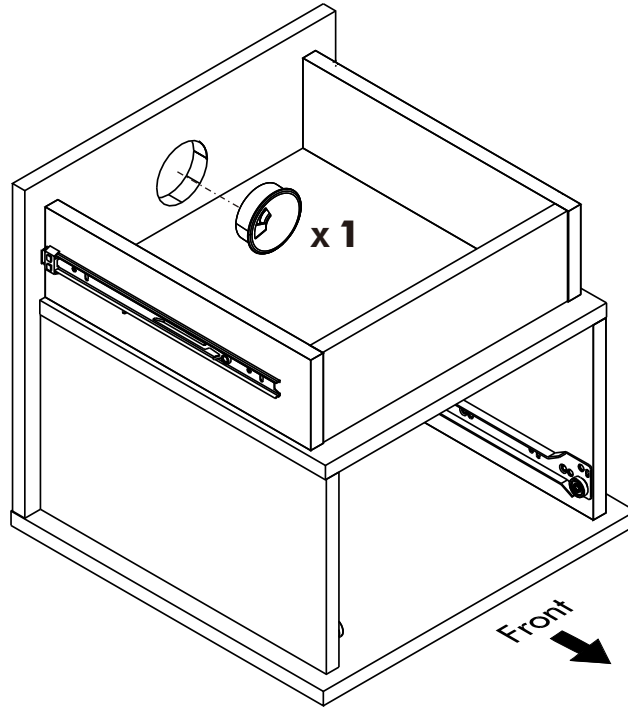

10.

