

SAGGIO-P

Corner desk + hutch

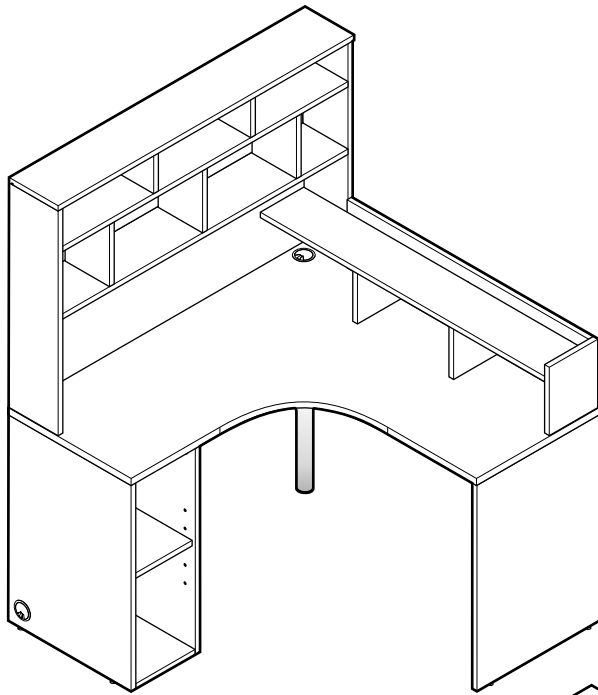

LEFT

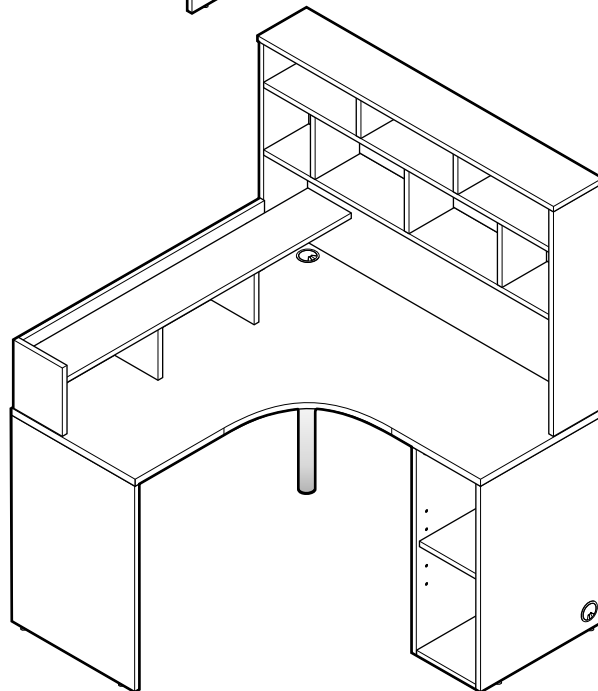

RIGHT

CONNECT SYSTEM

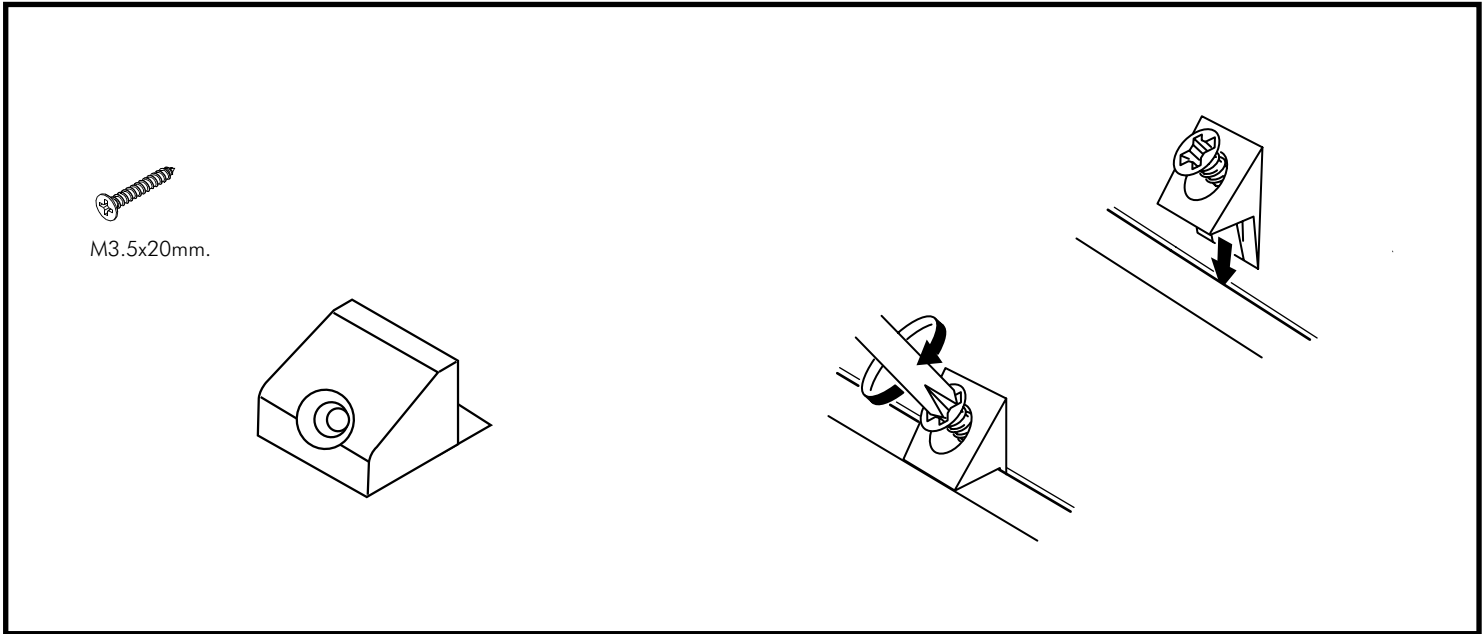
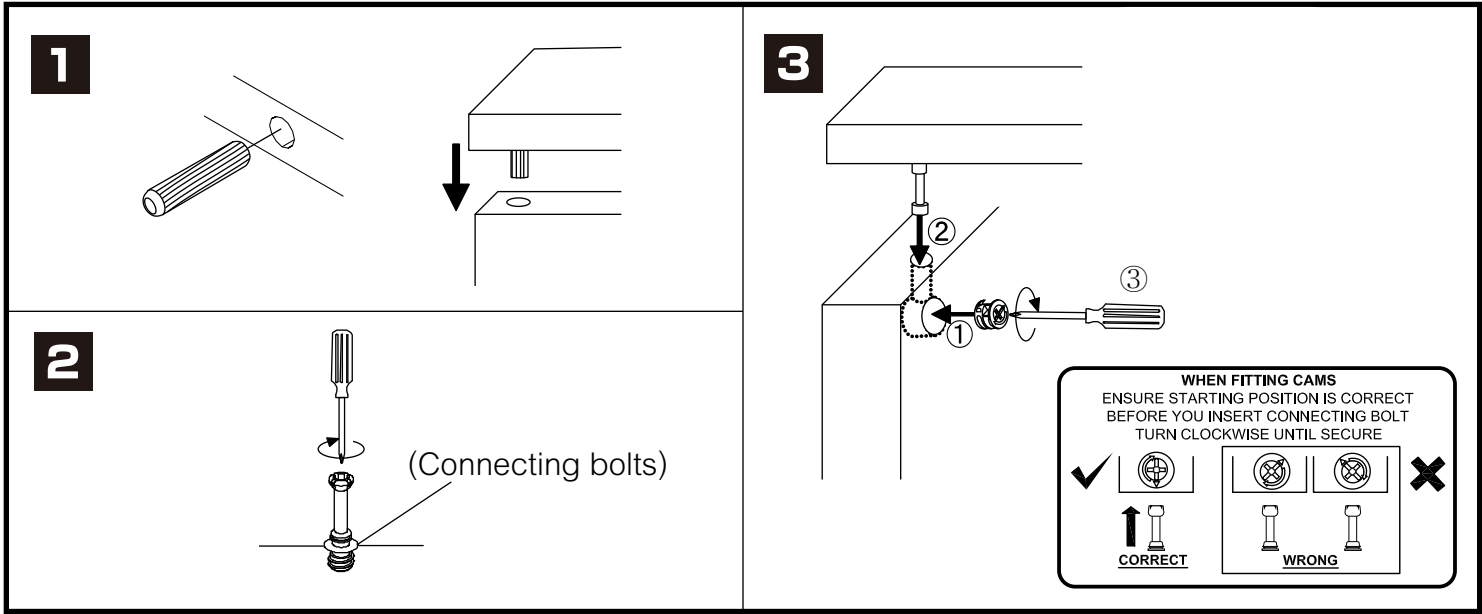

HARDWARE



19 mm.
X 31



12 mm.
X 9

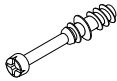

X 40

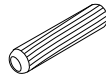

8x35mm.
X 63



6x35mm.
X 12



X 27

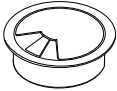

X 3



X 8



F+M4x40
X 14



X 4



X 2

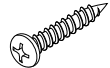

P+4x5/8"
X 2

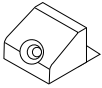

X 6

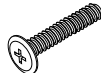

TF+M6x20
X 4

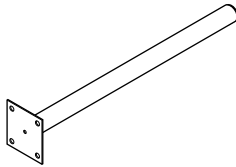

X 1

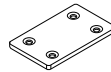

X 2



F+M3.5x13
X 16



X 4



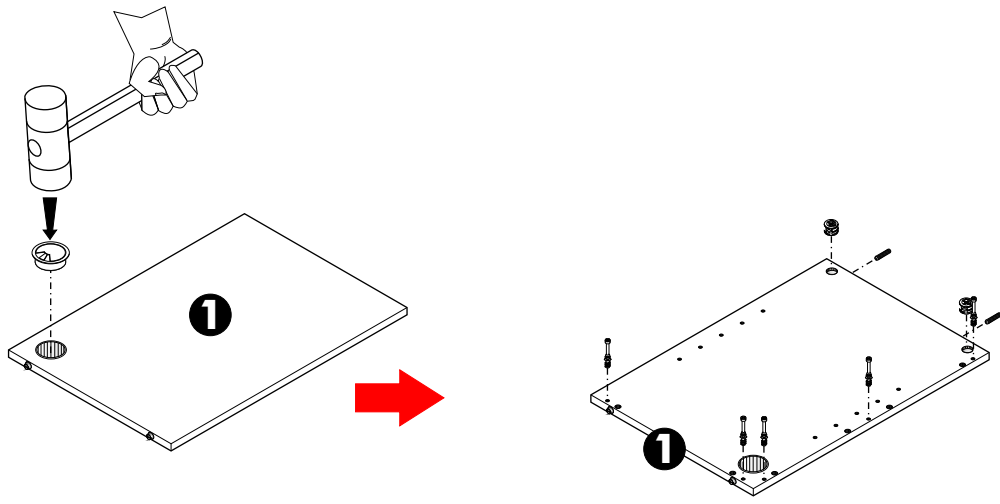

F+M3.5x20
X 6

1.

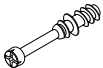

19 mm.		x4
--------	---	-----------

		x10
--	---	------------

8x35mm.		x4
---------	---	-----------

		x2
--	---	-----------

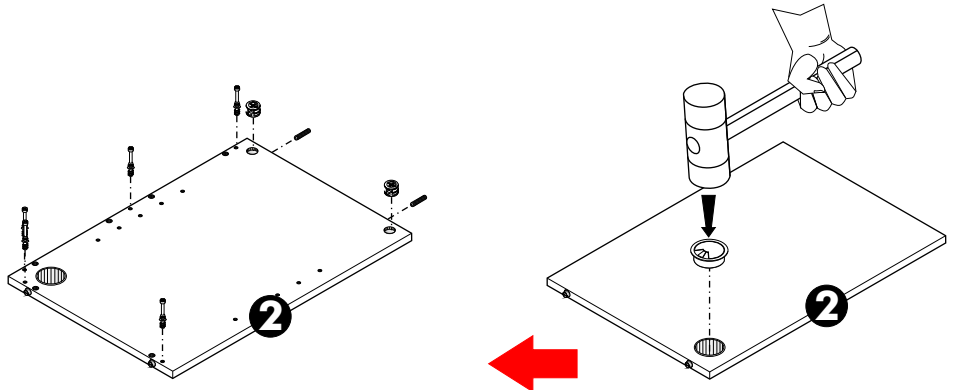

2.

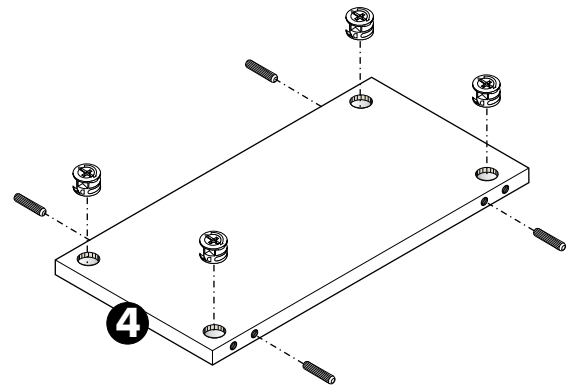
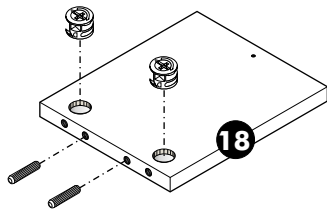
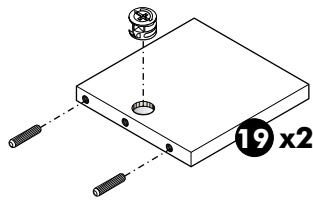

19 mm.		x8
--------	---	-----------

8x35mm.		x10
---------	---	------------

3.

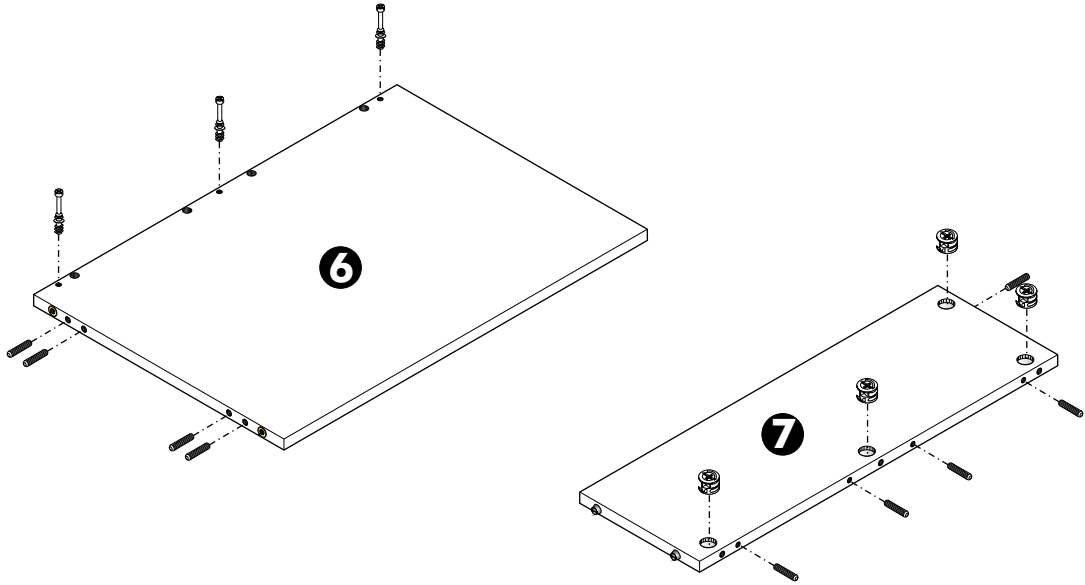

19 mm.		x4
--------	---	-----------

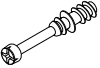
		x3
--	--	-----------

8x35mm.		x9
---------	---	-----------

4.

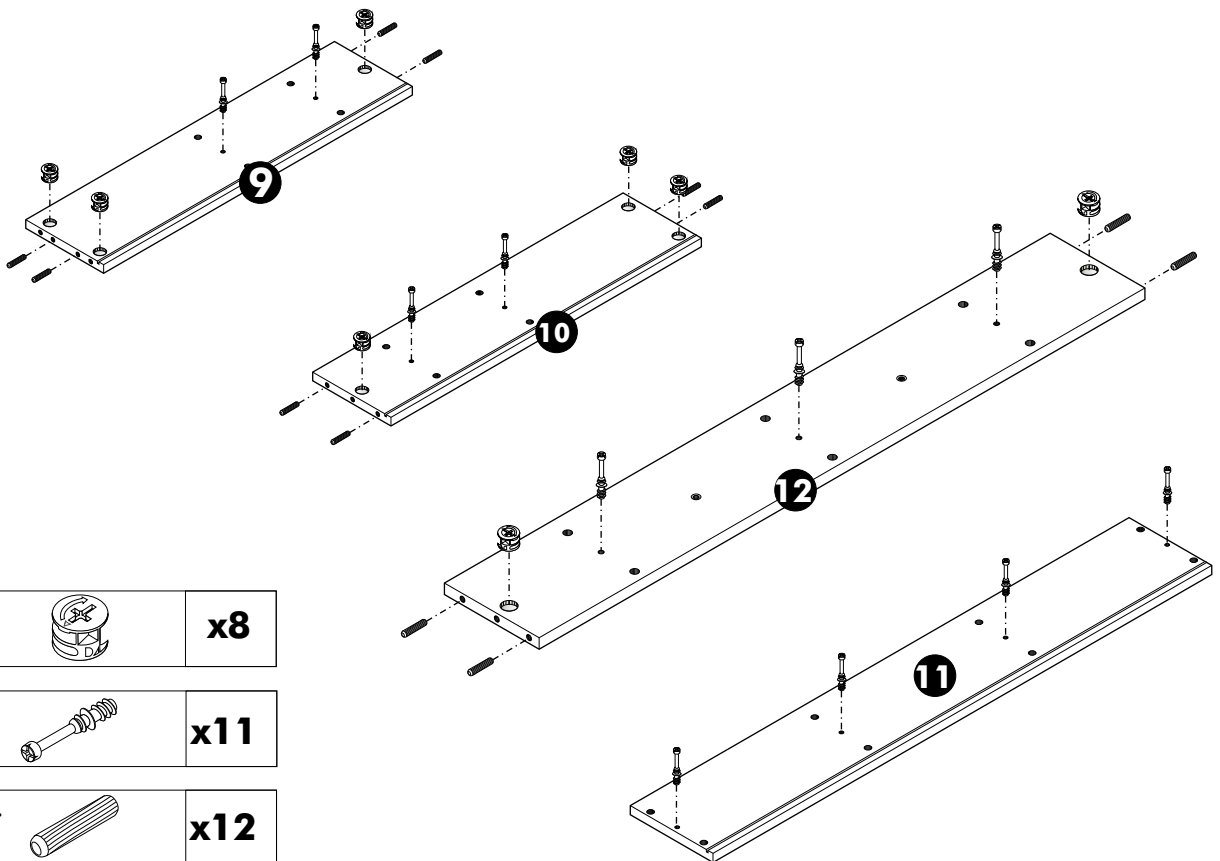

19 mm.		x8
--------	---	-----------

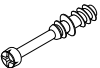
		x11
--	---	------------

8x35mm.		x12
---------	---	------------

5.

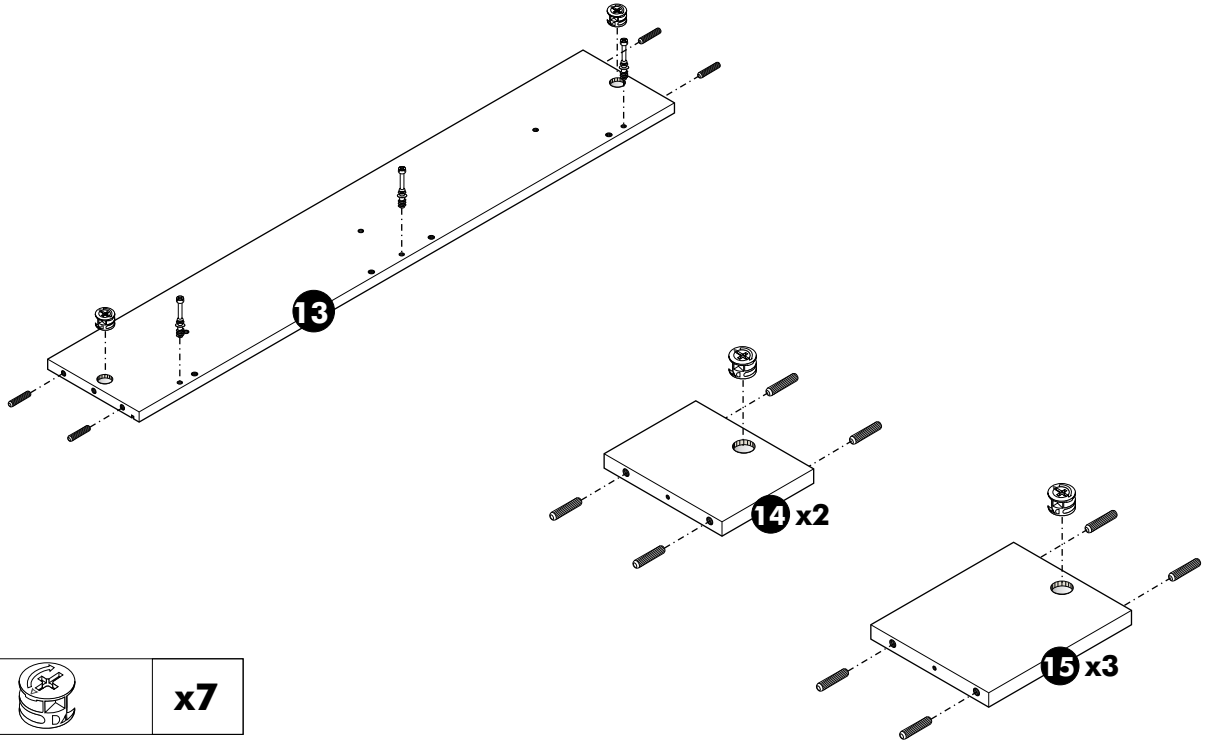

19 mm.		x7
--------	---	-----------

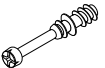
		x3
--	--	-----------

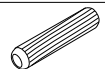
8x35mm.		x24
---------	---	------------

6.

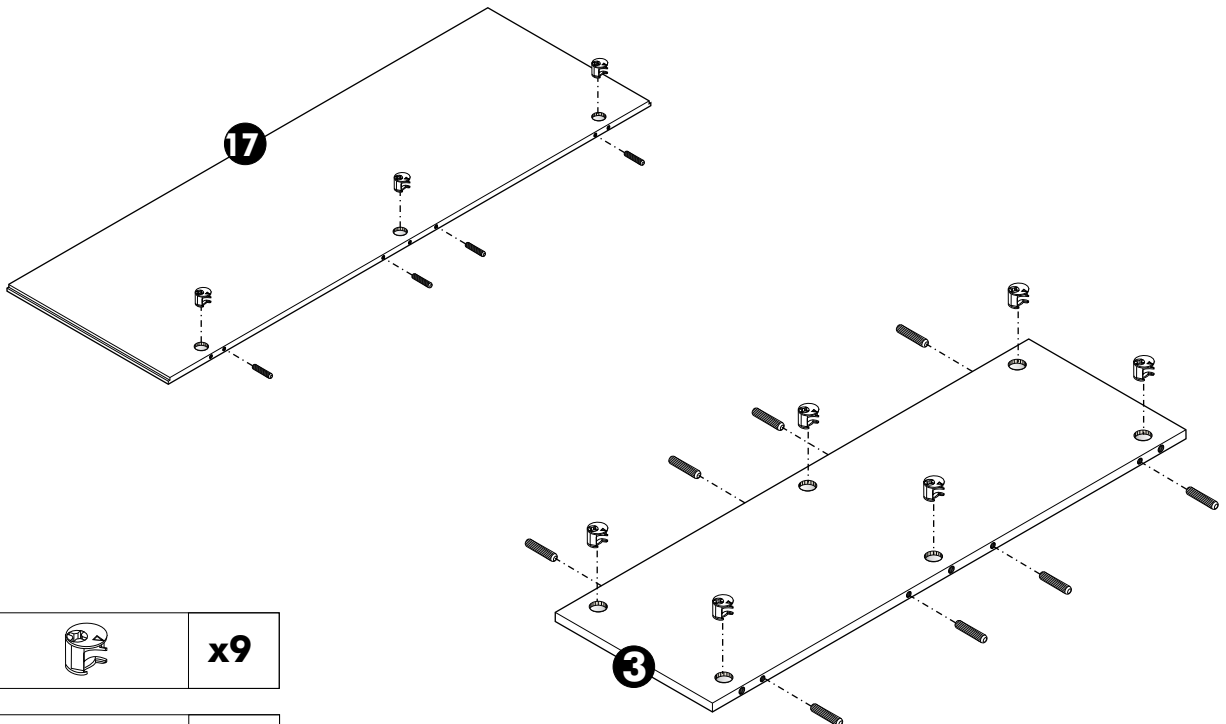

12 mm.		x9
--------	---	-----------

6x35mm.		x12
---------	---	------------

7. LEFT + RIGHT

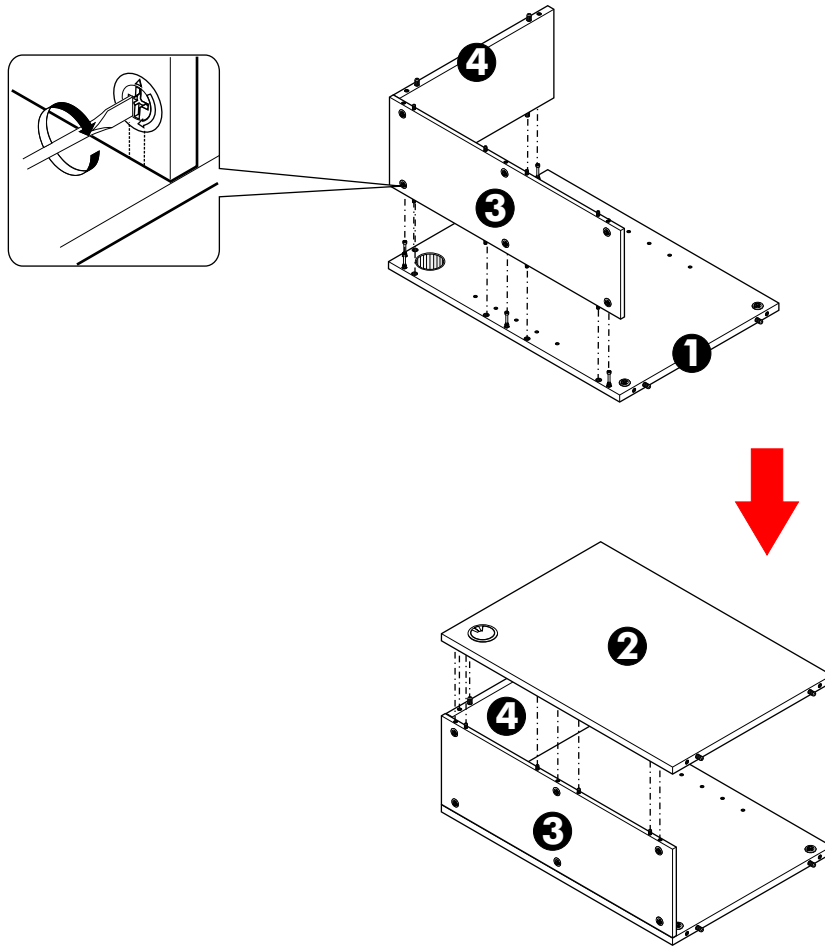

8. LEFT

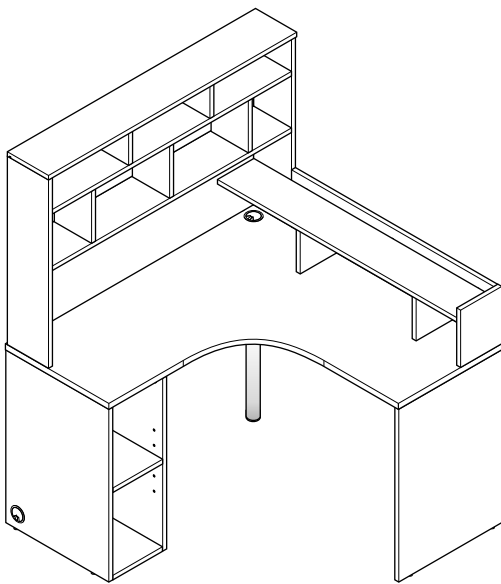

RIGHT

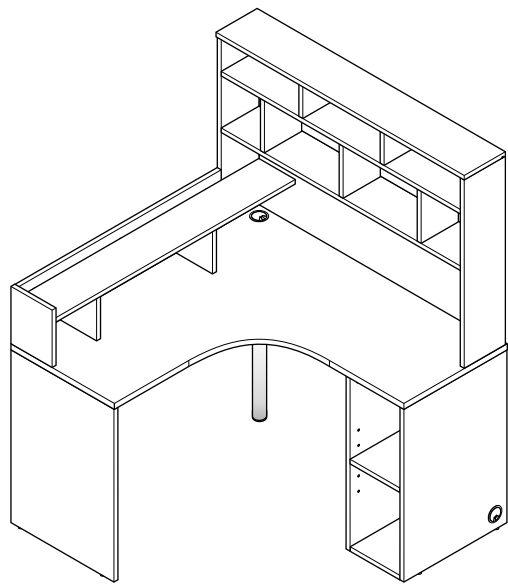

9. LEFT

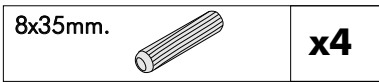
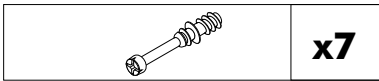
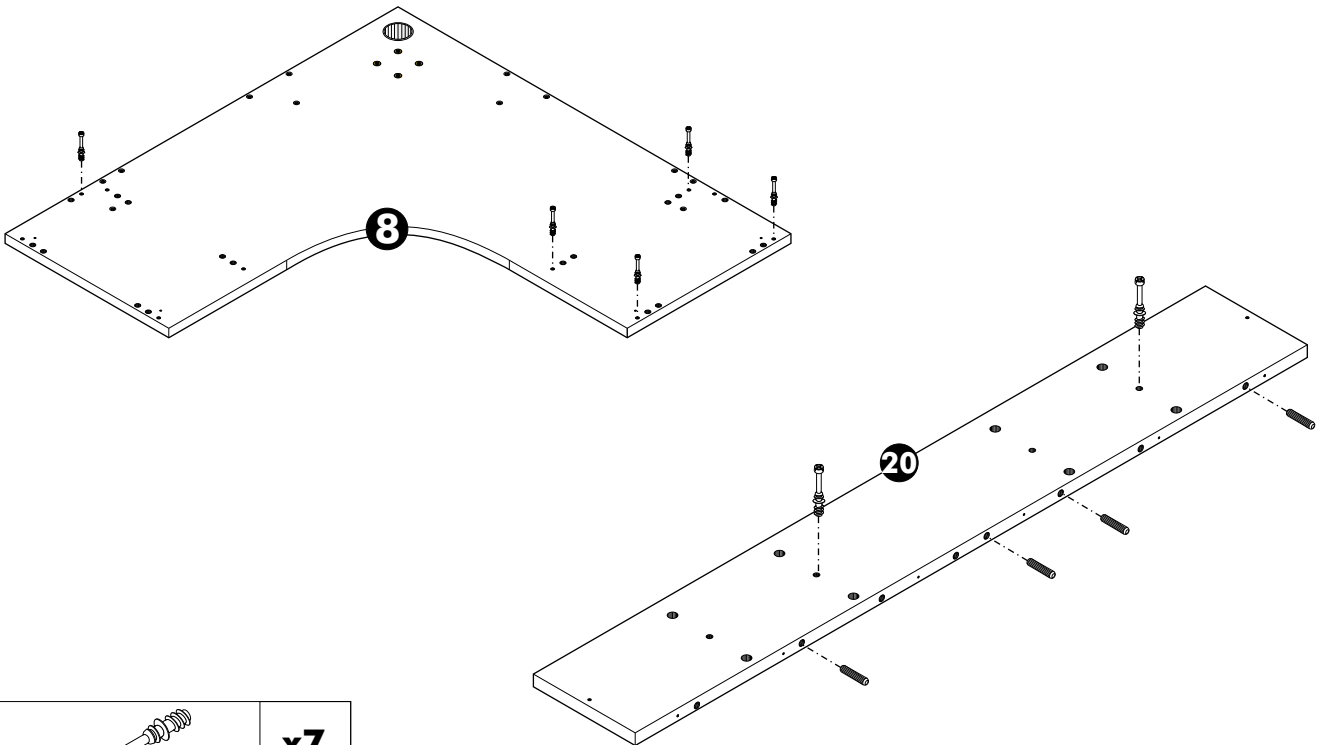

1. LEFT

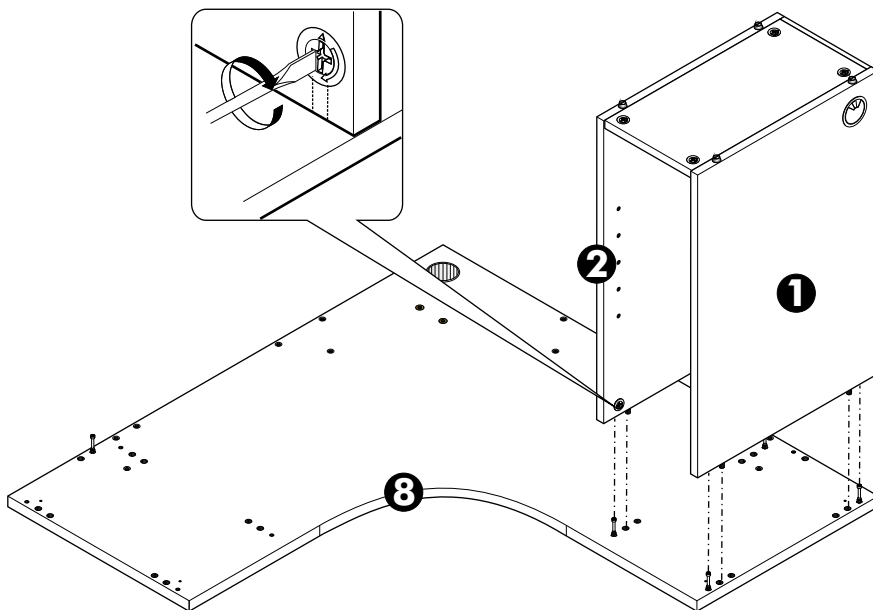

2. LEFT

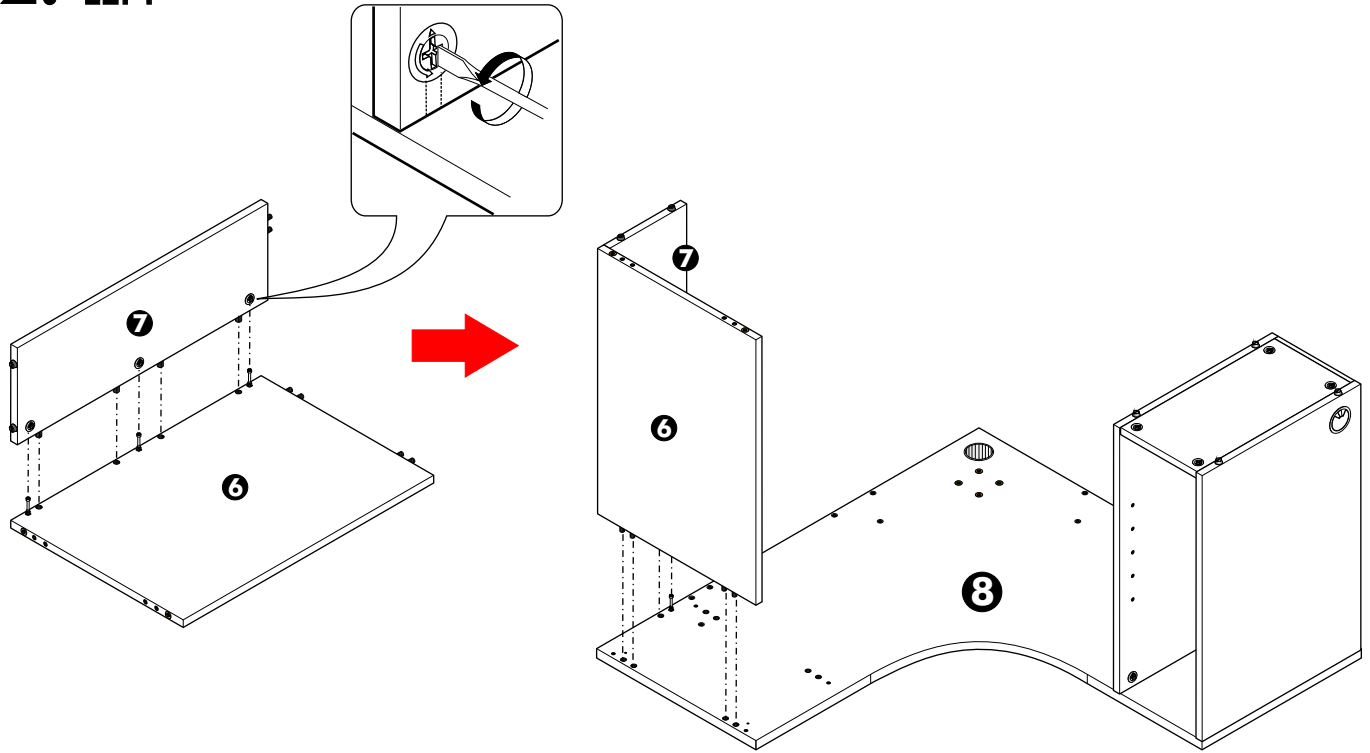

3. LEFT

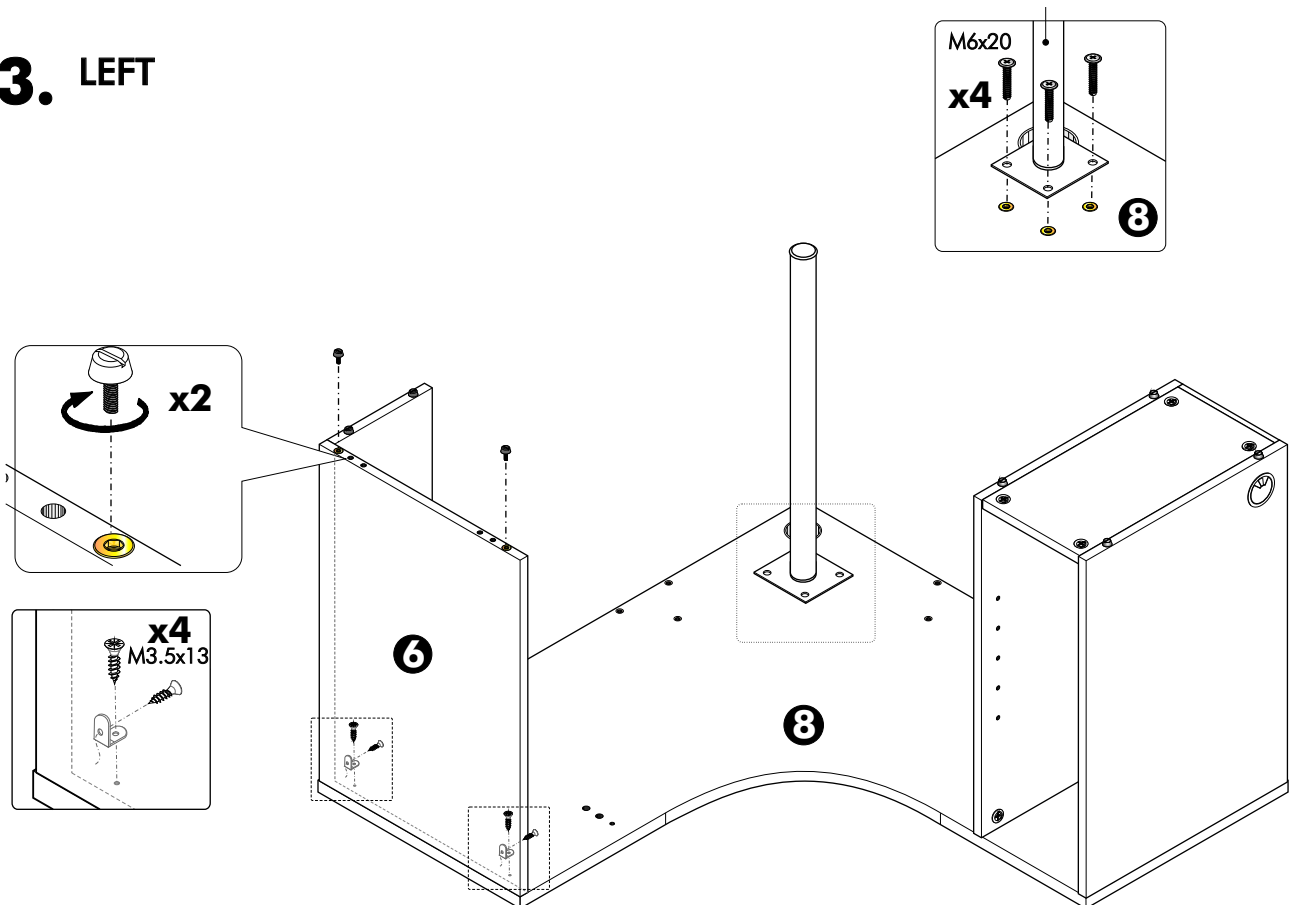

4. LEFT +RIGHT

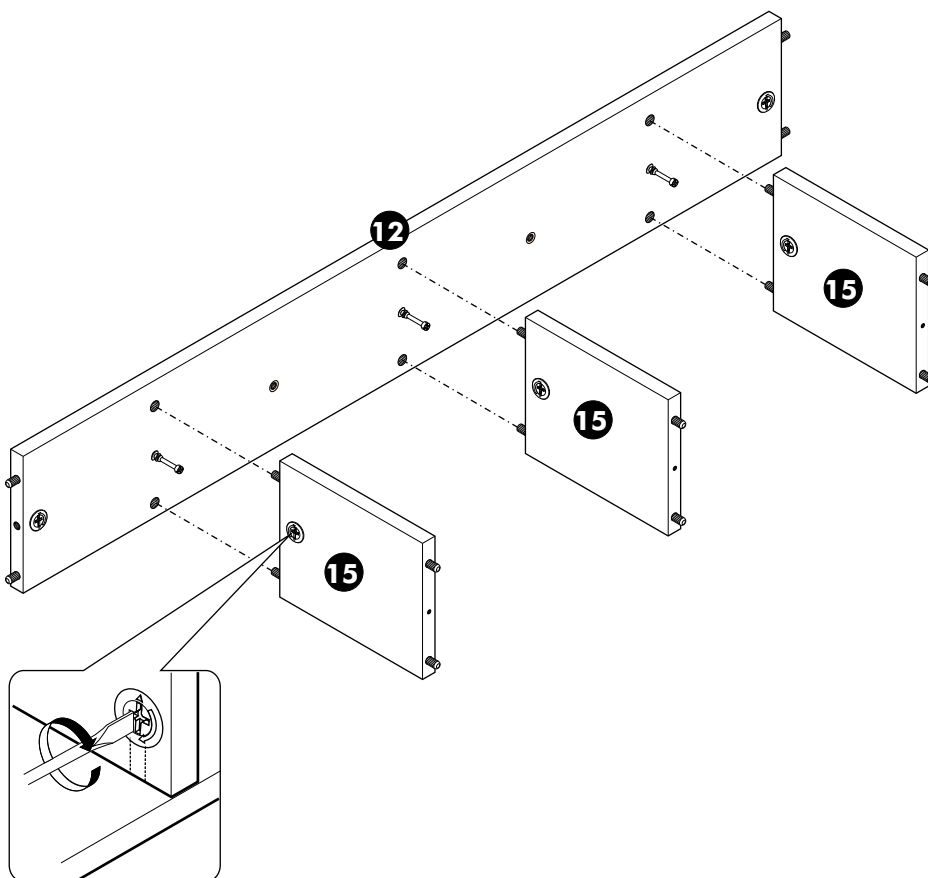

5. LEFT +RIGHT

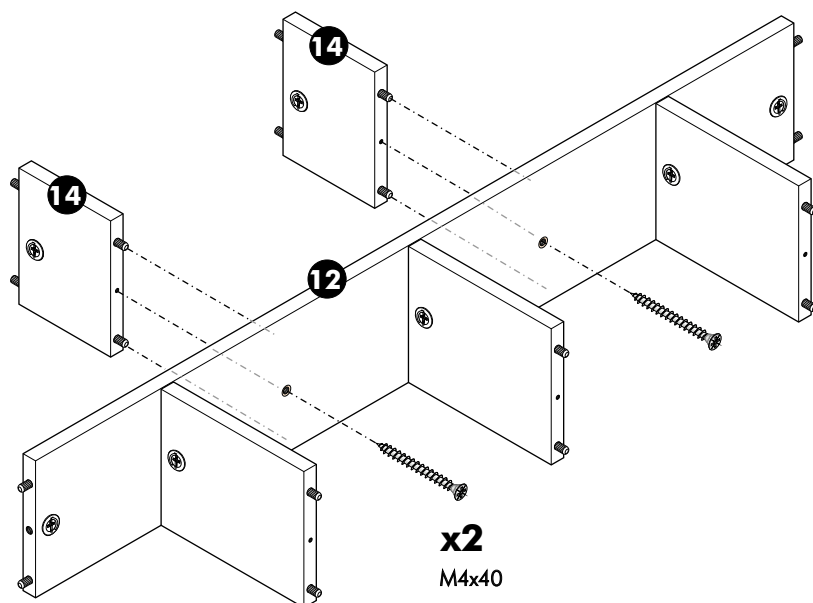

6. LEFT +RIGHT

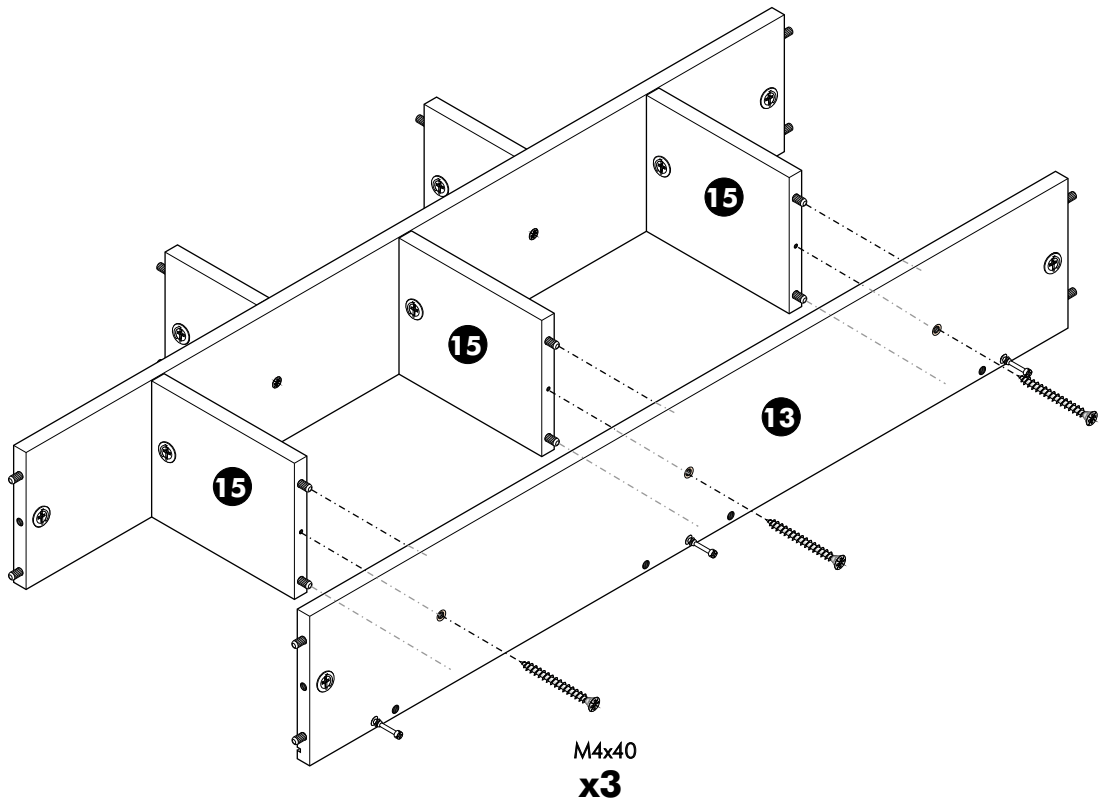

7. LEFT +RIGHT

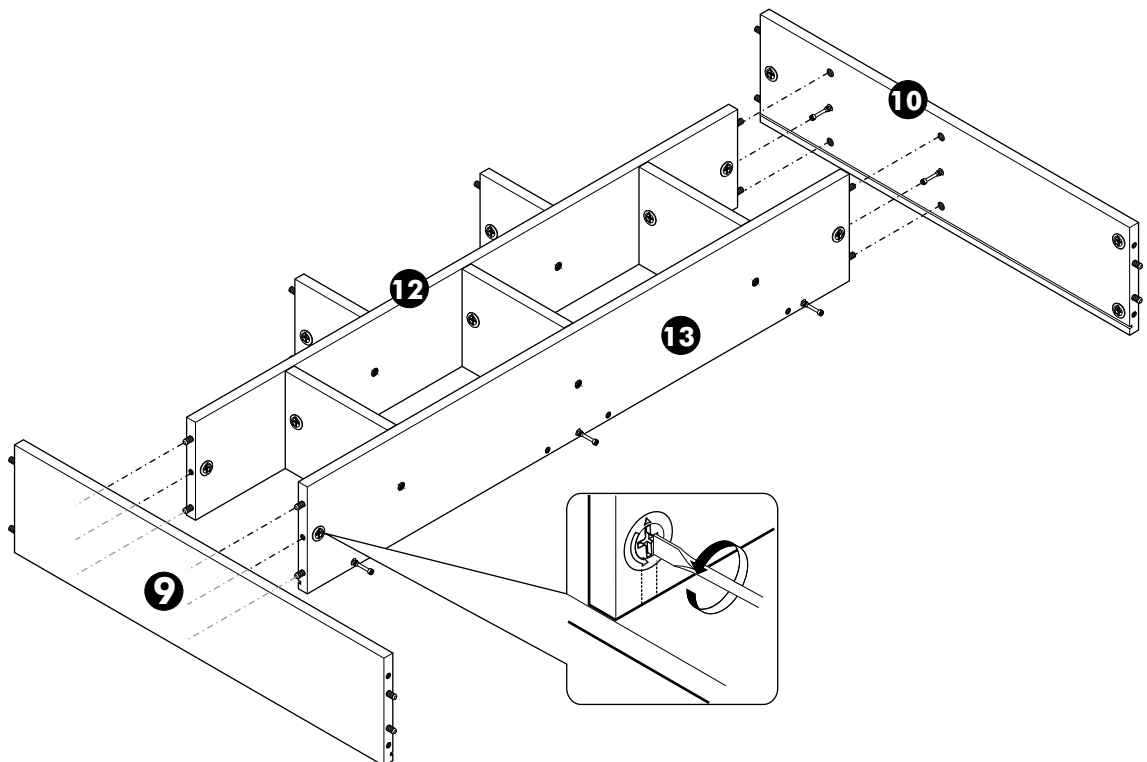

8. LEFT + RIGHT

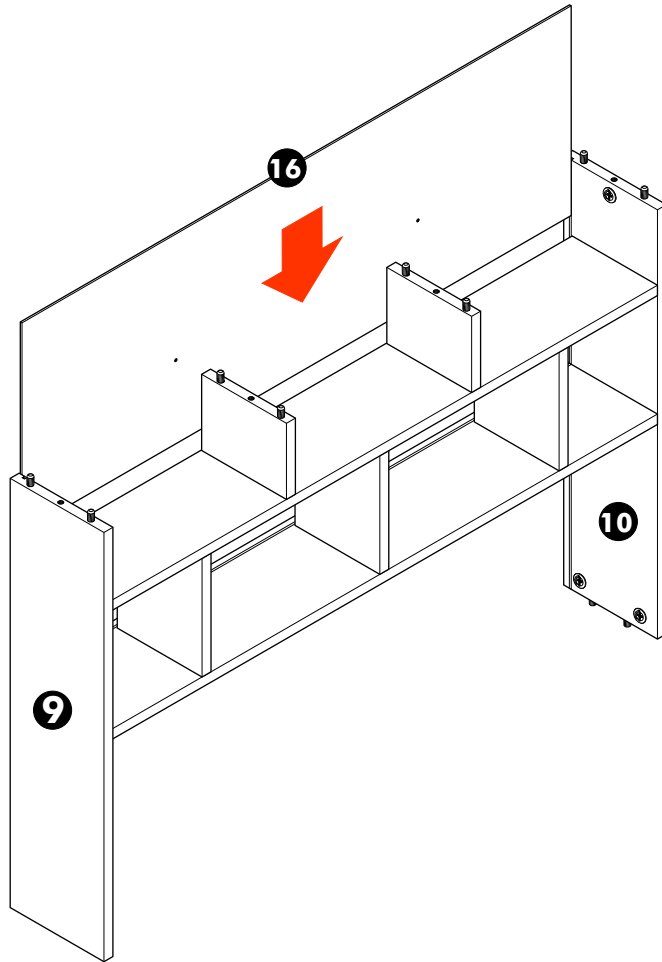

9. LEFT + RIGHT

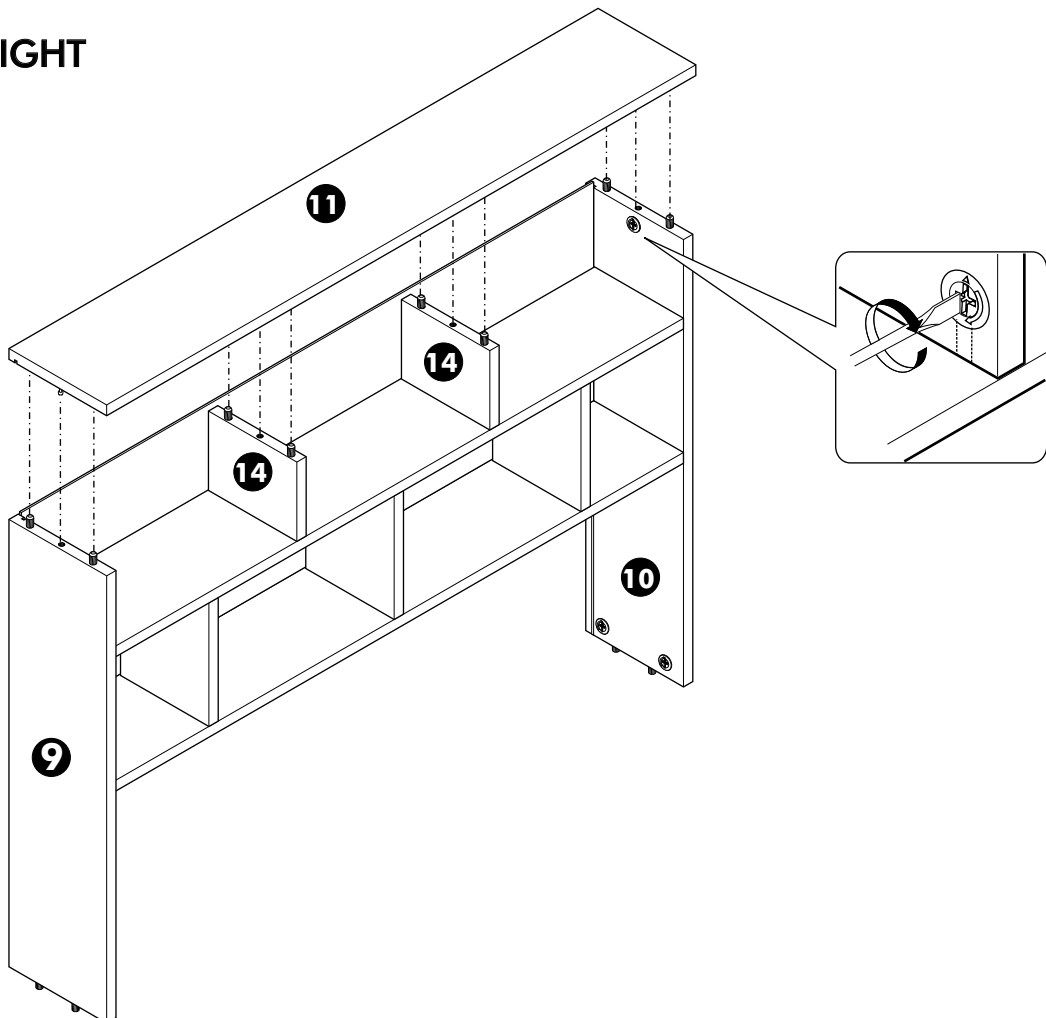

10. LEFT + RIGHT

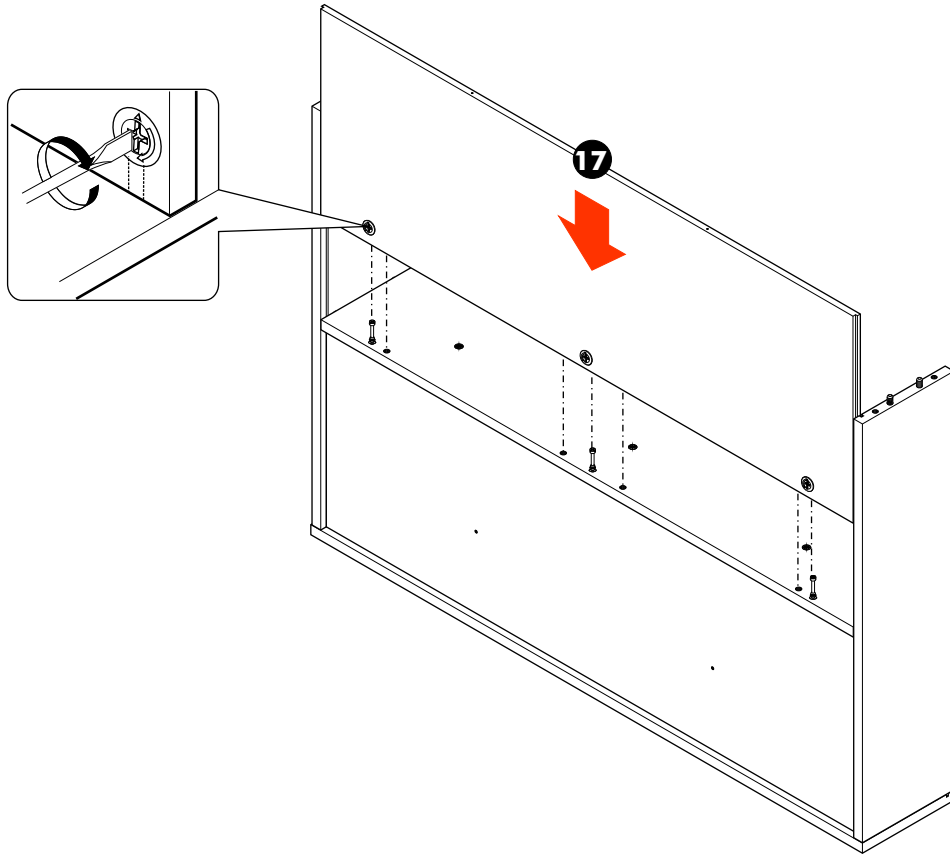

11. LEFT - RIGHT

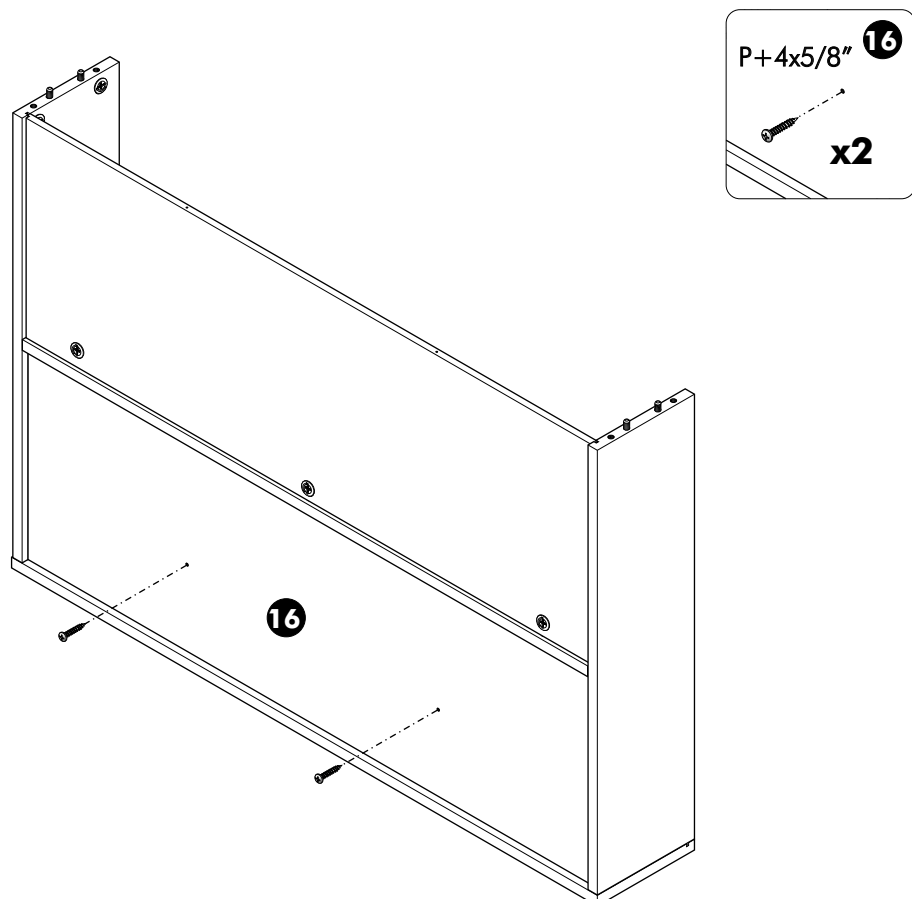

12. LEFT

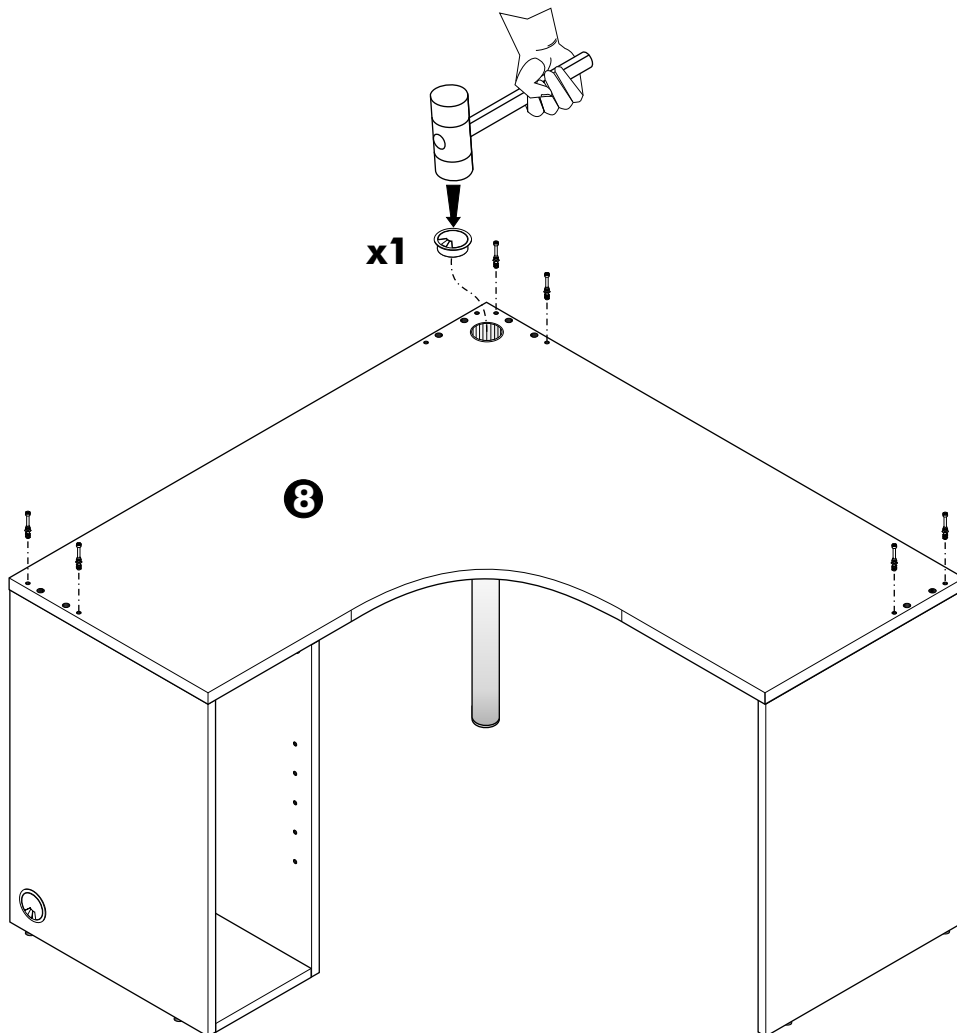

13. LEFT

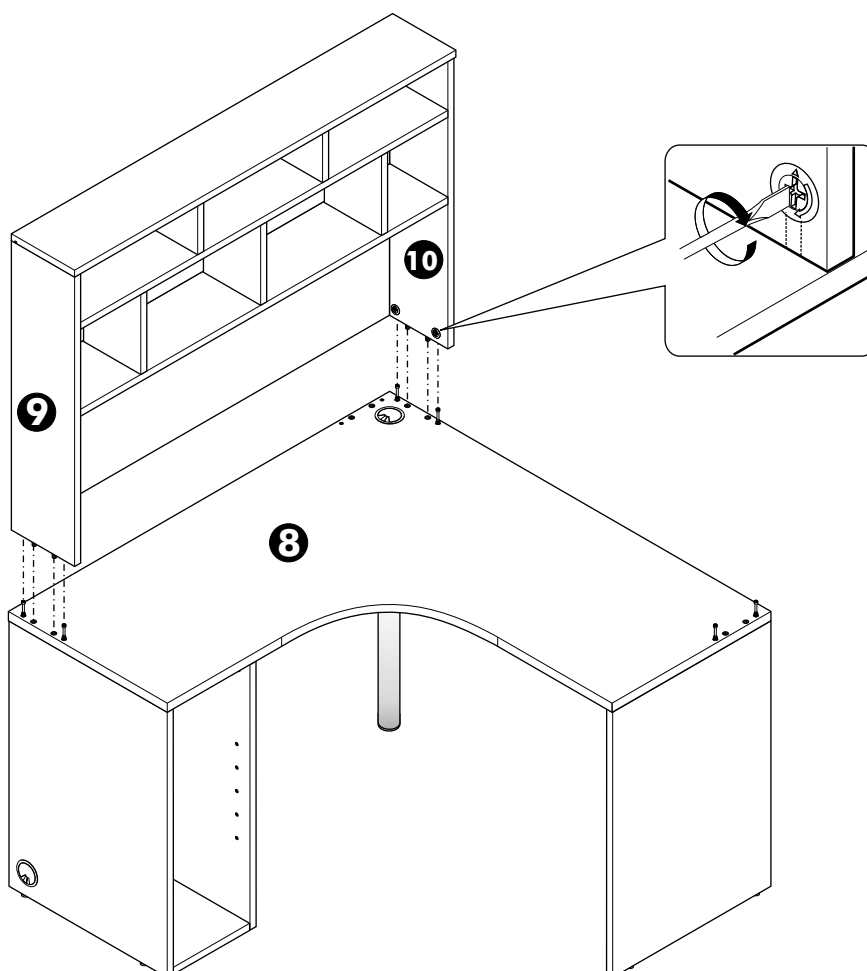

14. LEFT

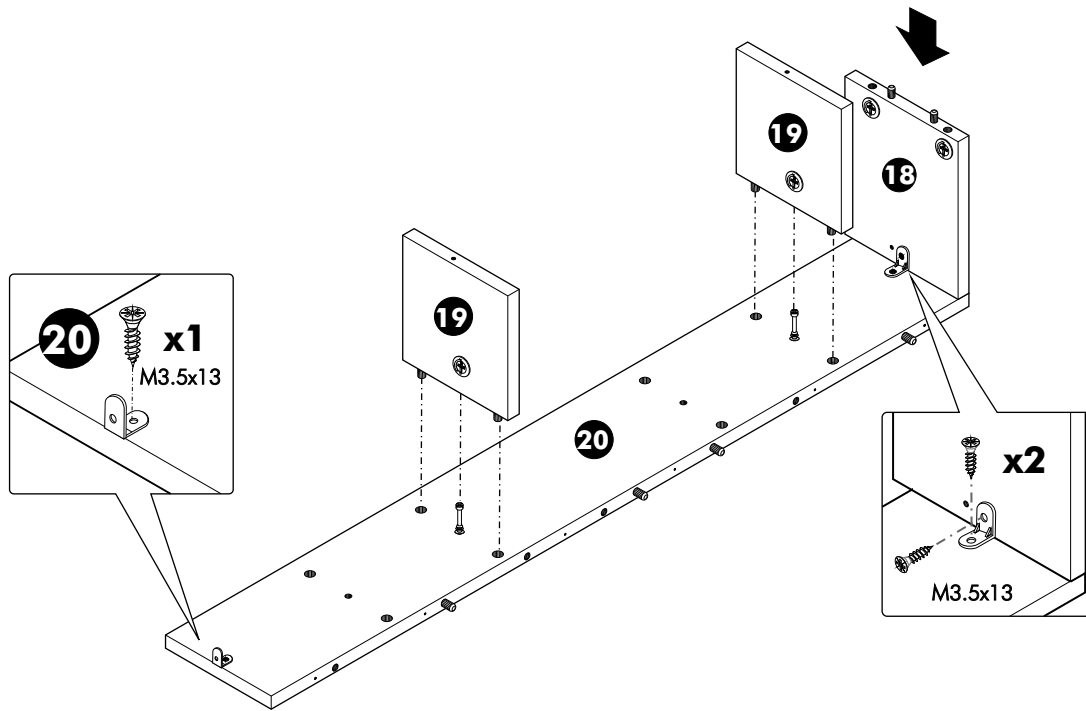

15. LEFT

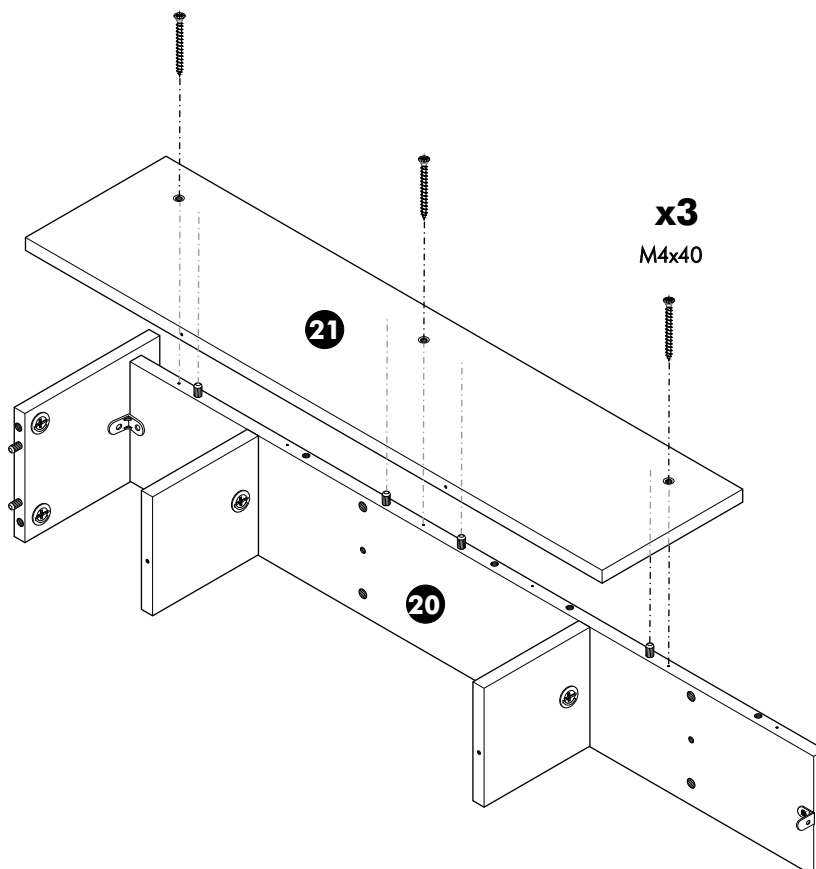

16. LEFT

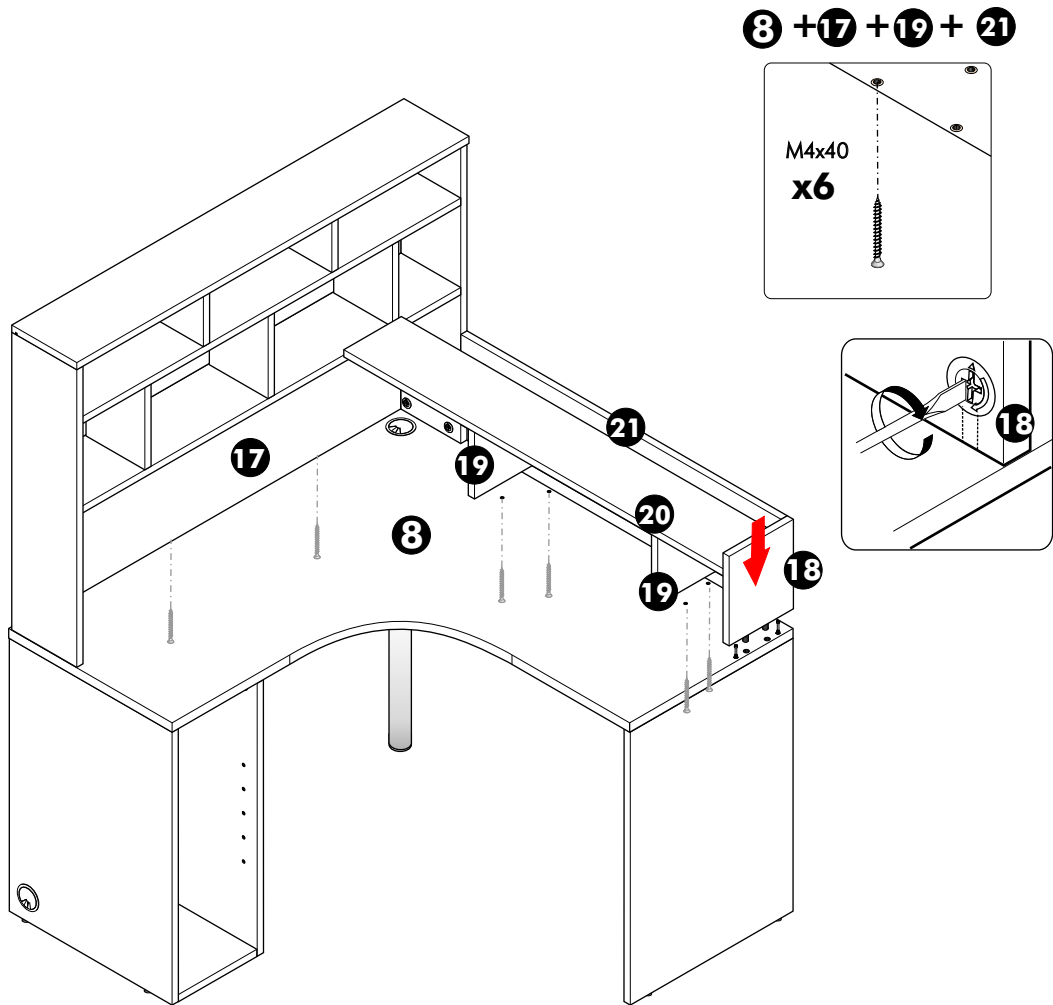

17. LEFT

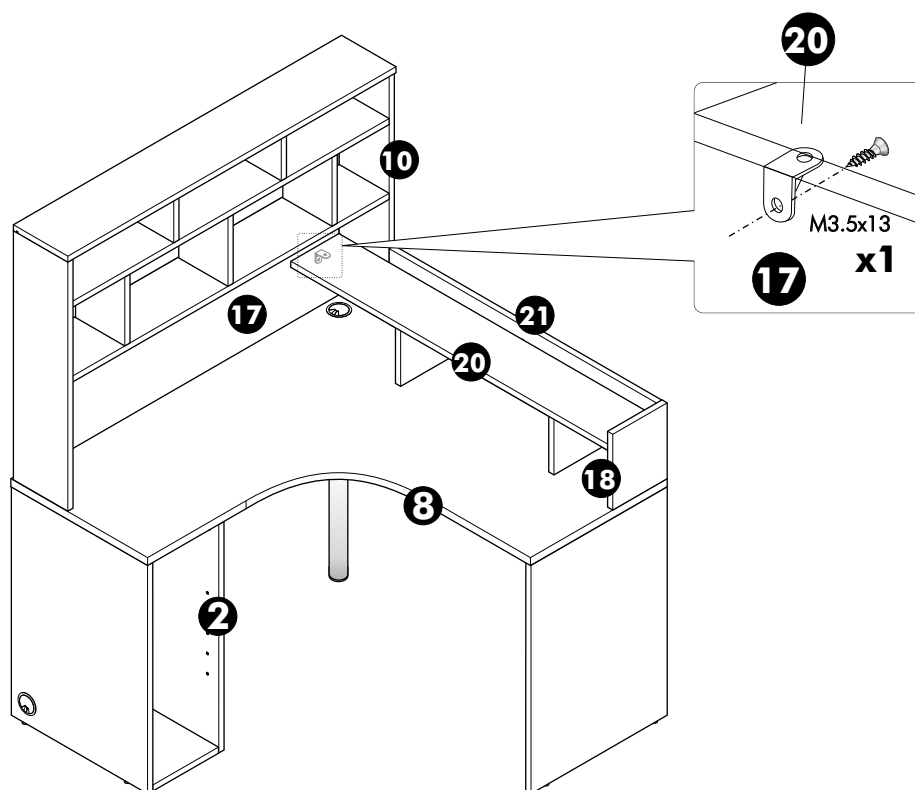

18. LEFT

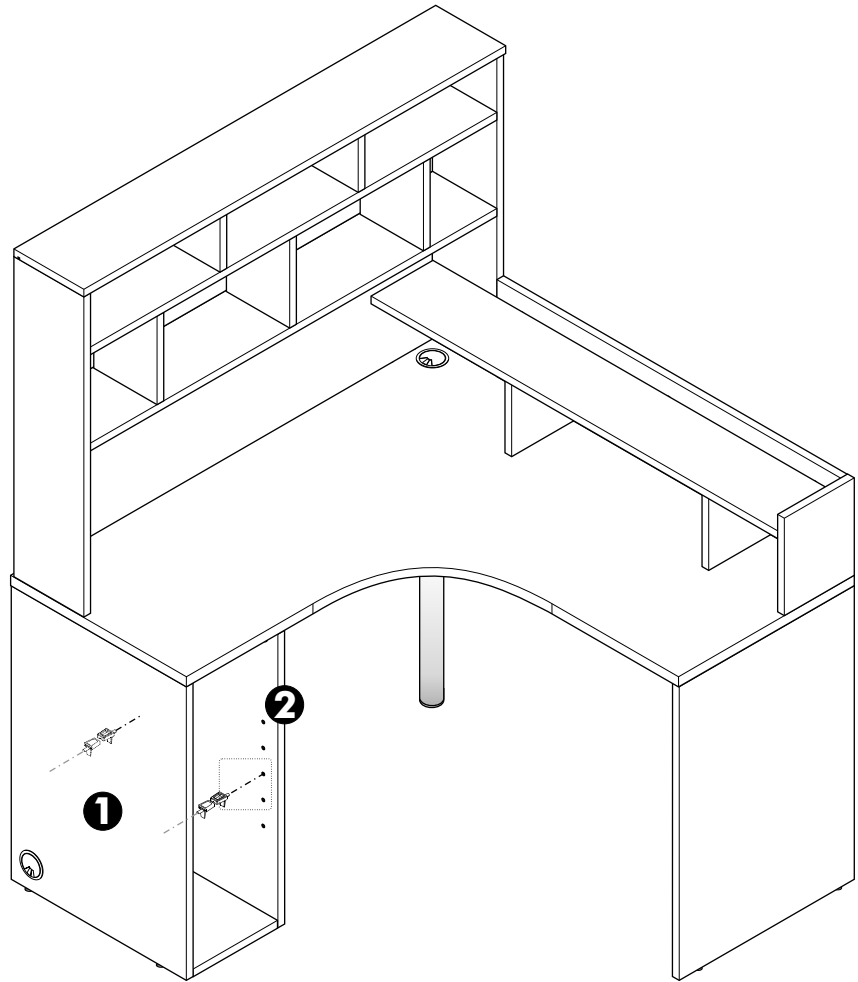
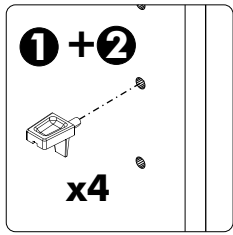

19. LEFT

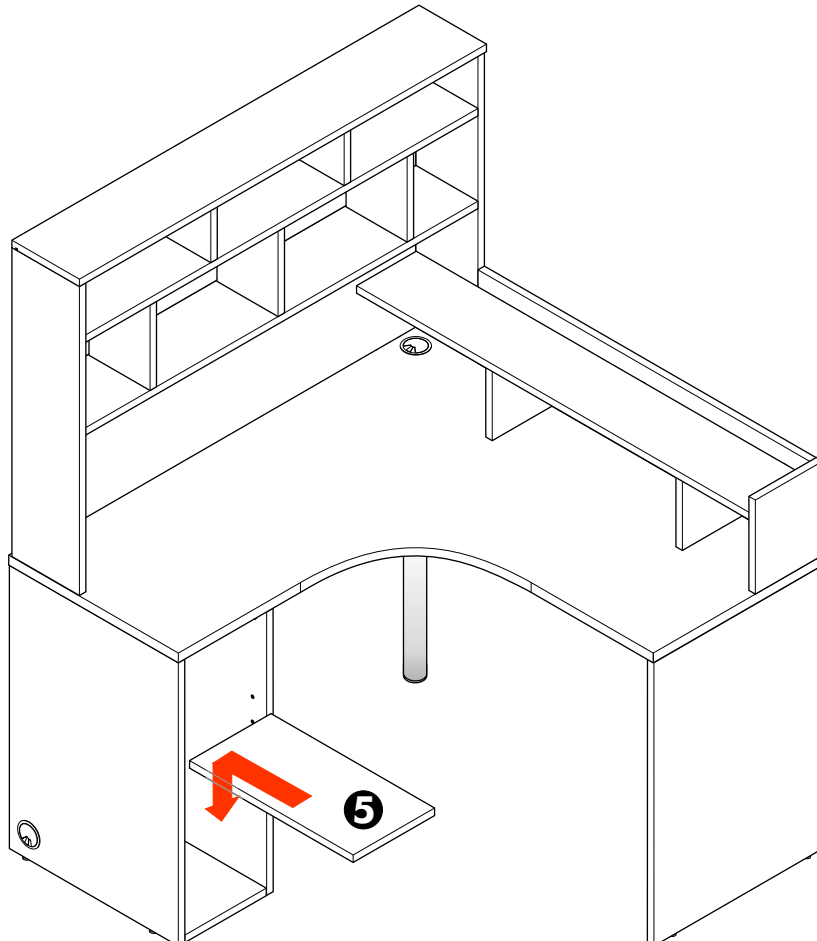

20. LEFT

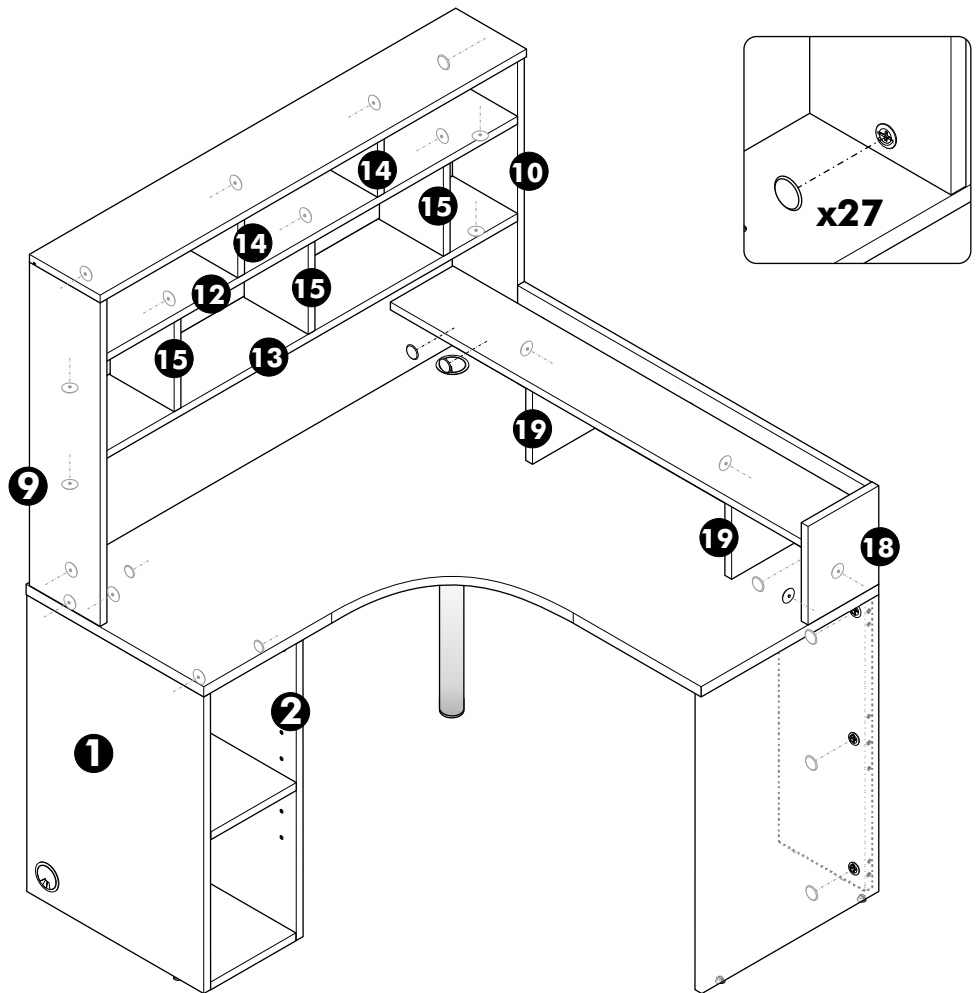

21. LEFT

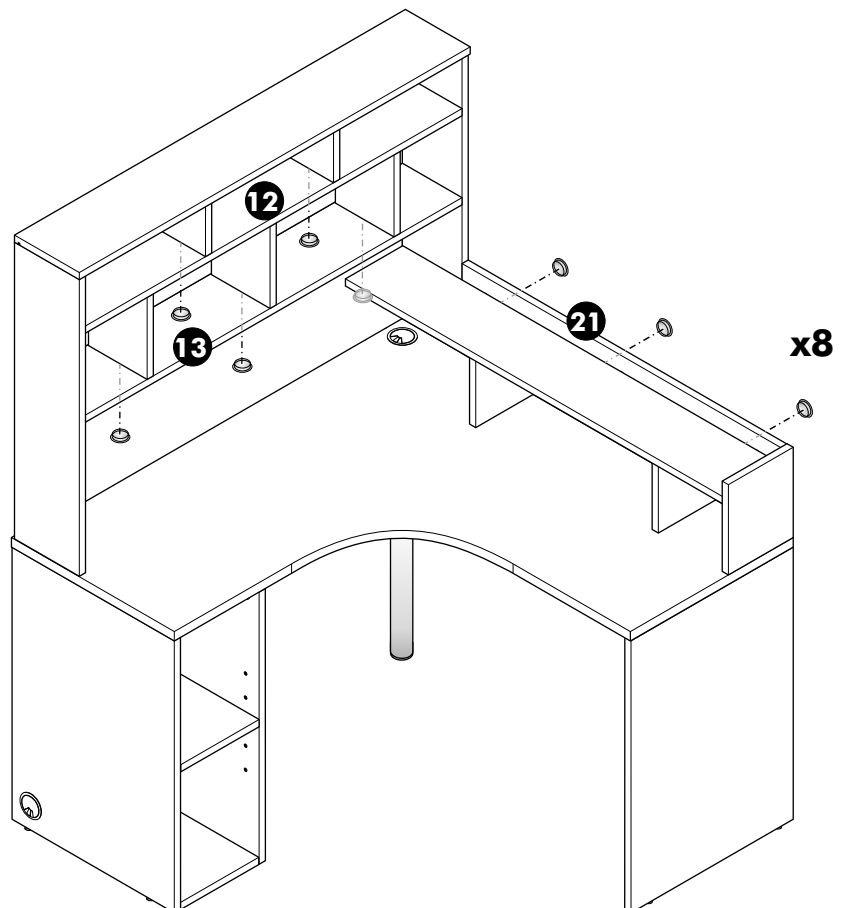

22. LEFT

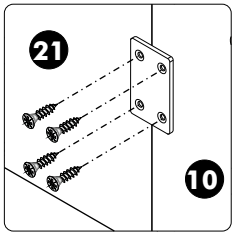

x8
M3.5x13

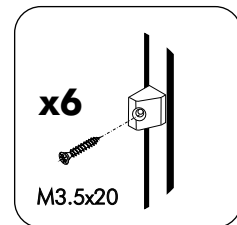
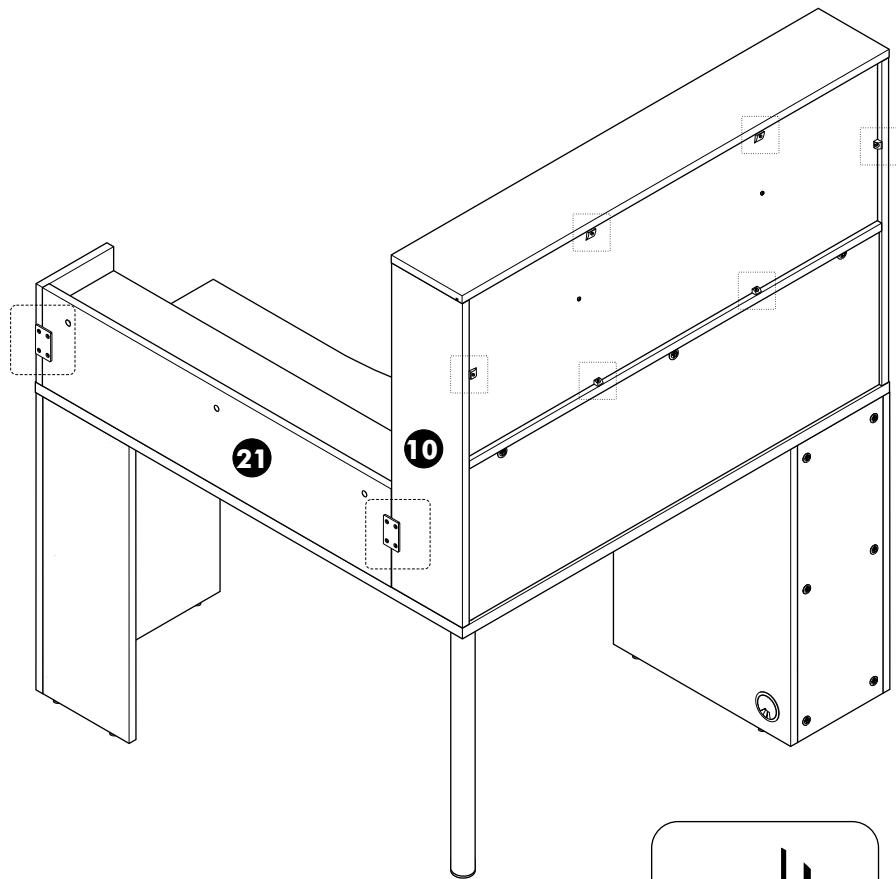

1. RIGHT

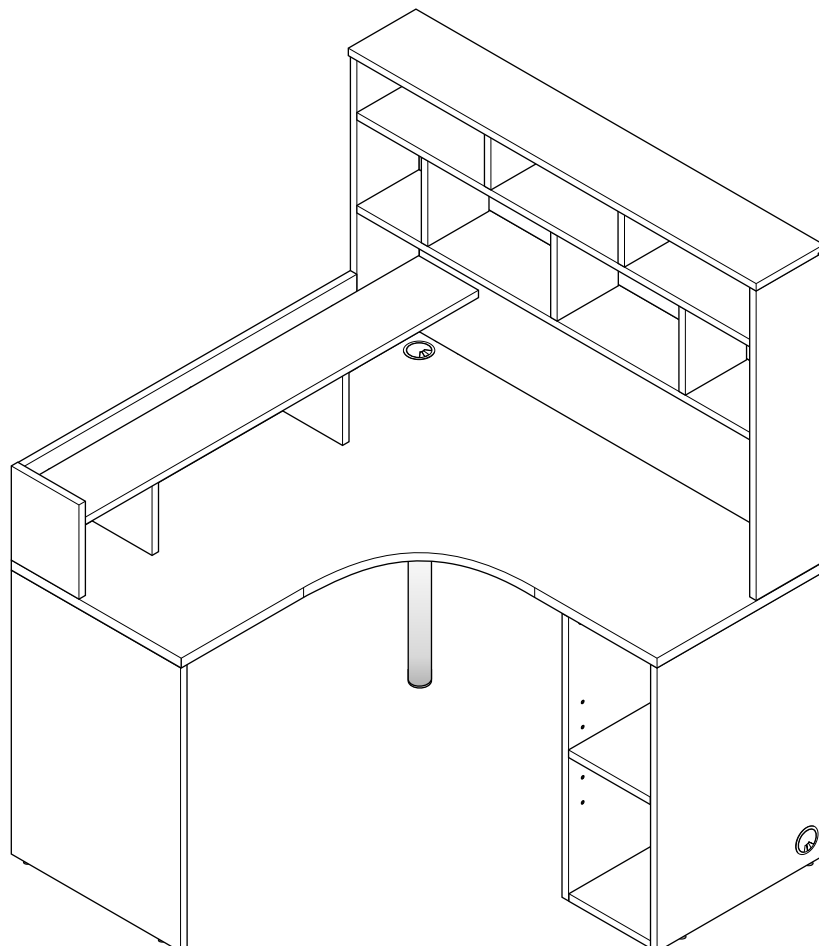

2. RIGHT

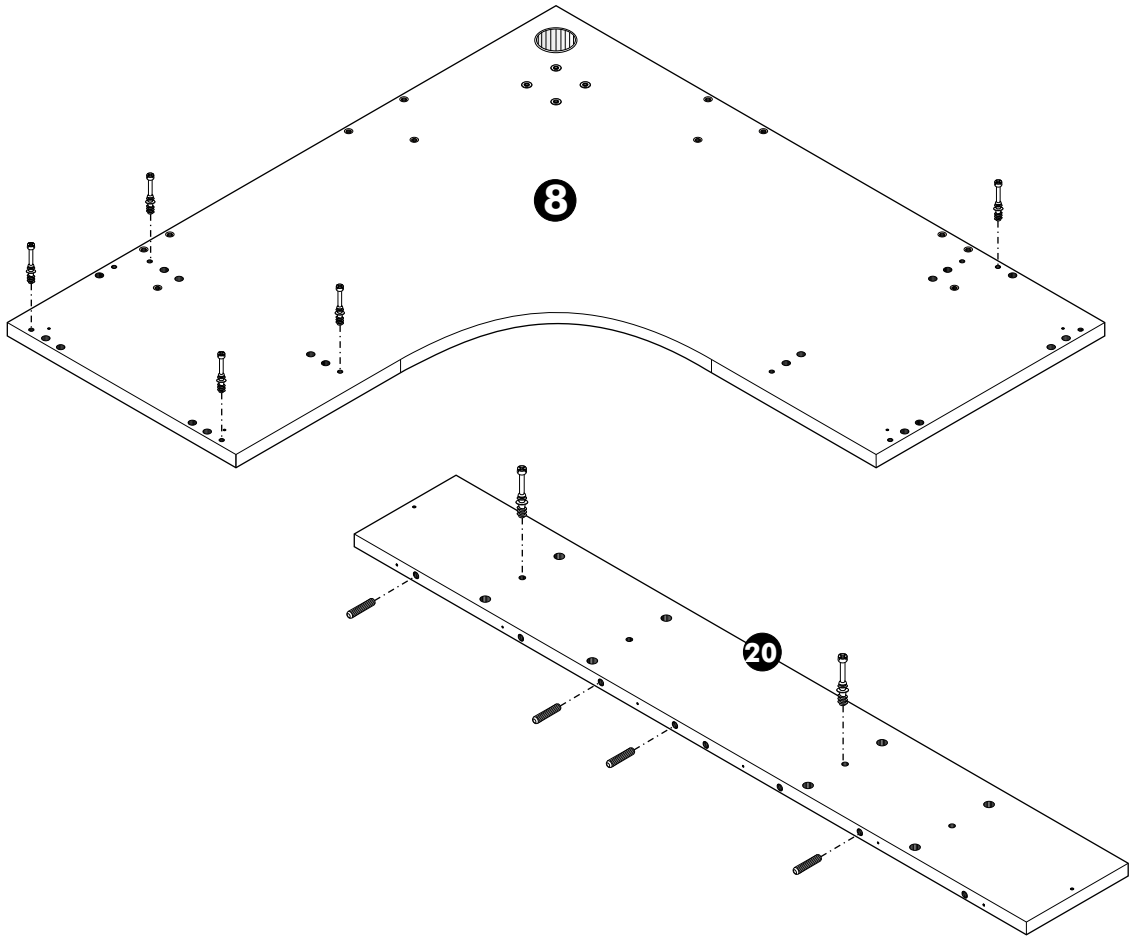

3. RIGHT

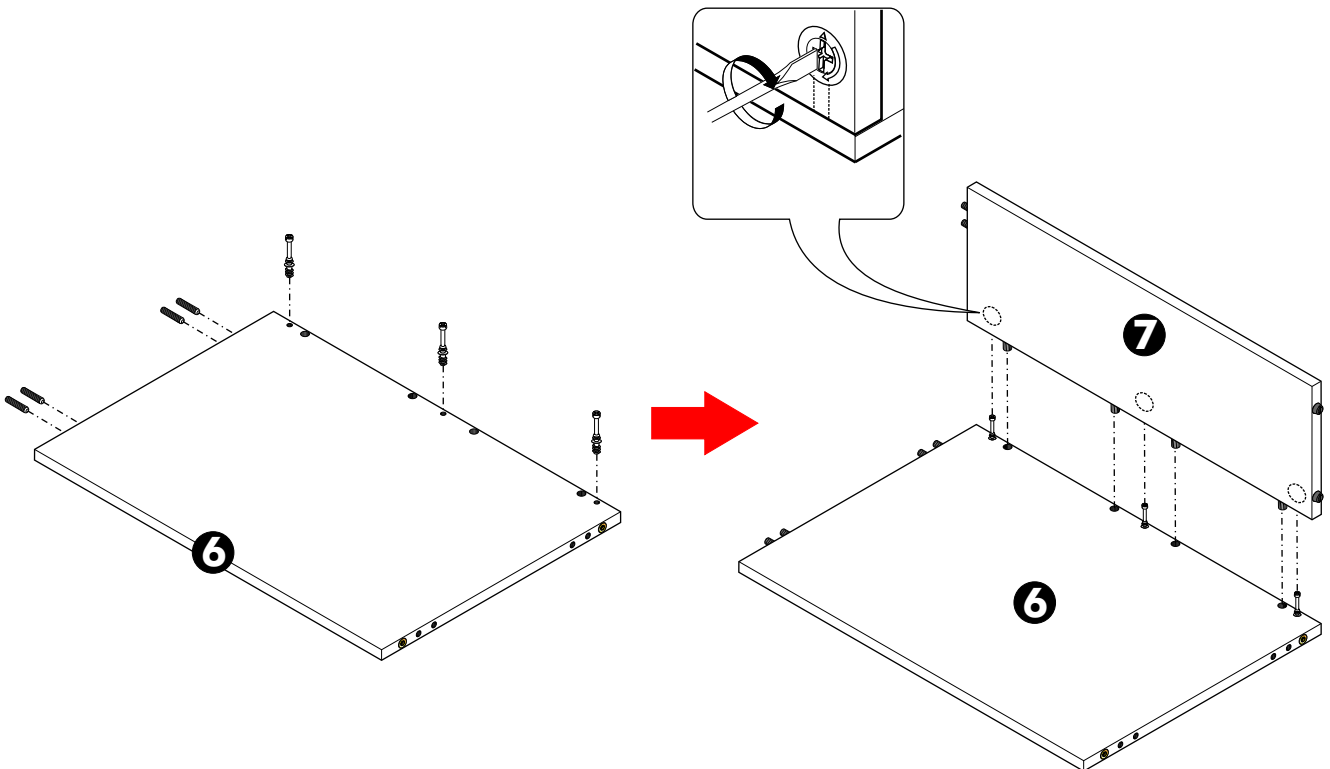

4. RIGHT

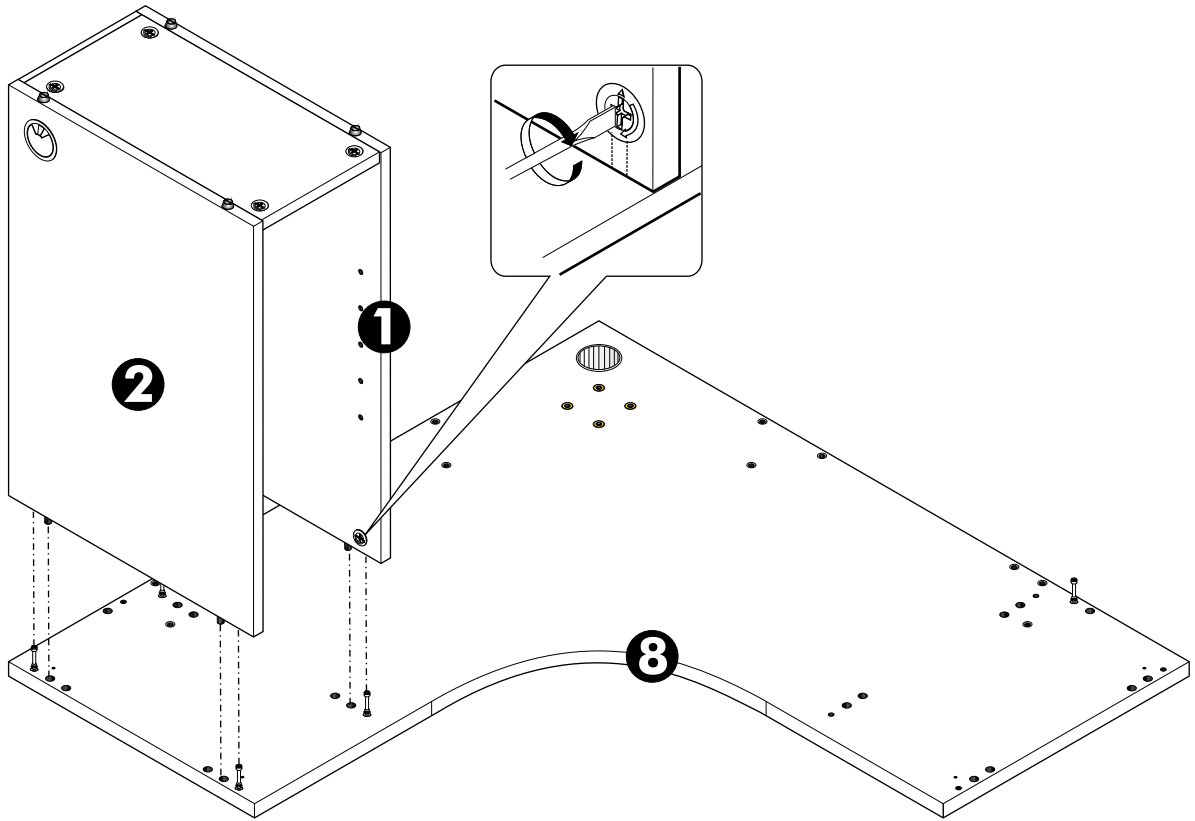

5. RIGHT

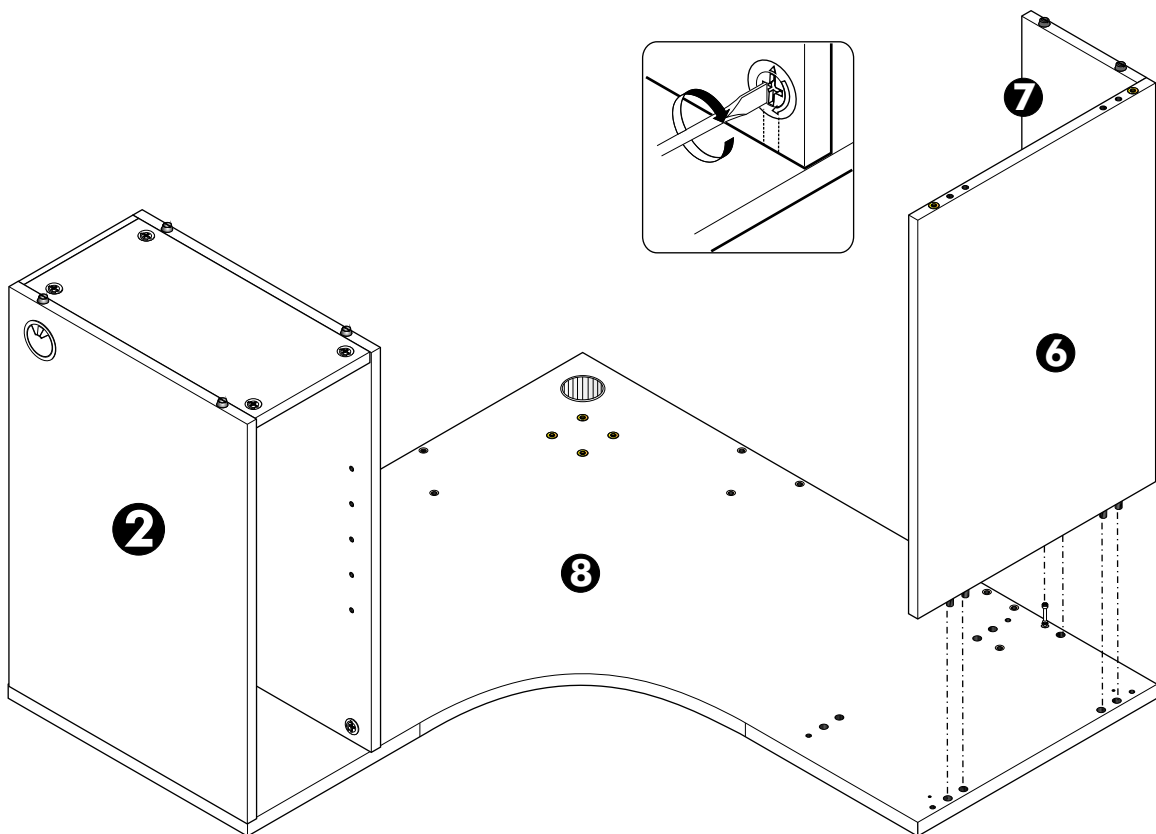

6. RIGHT

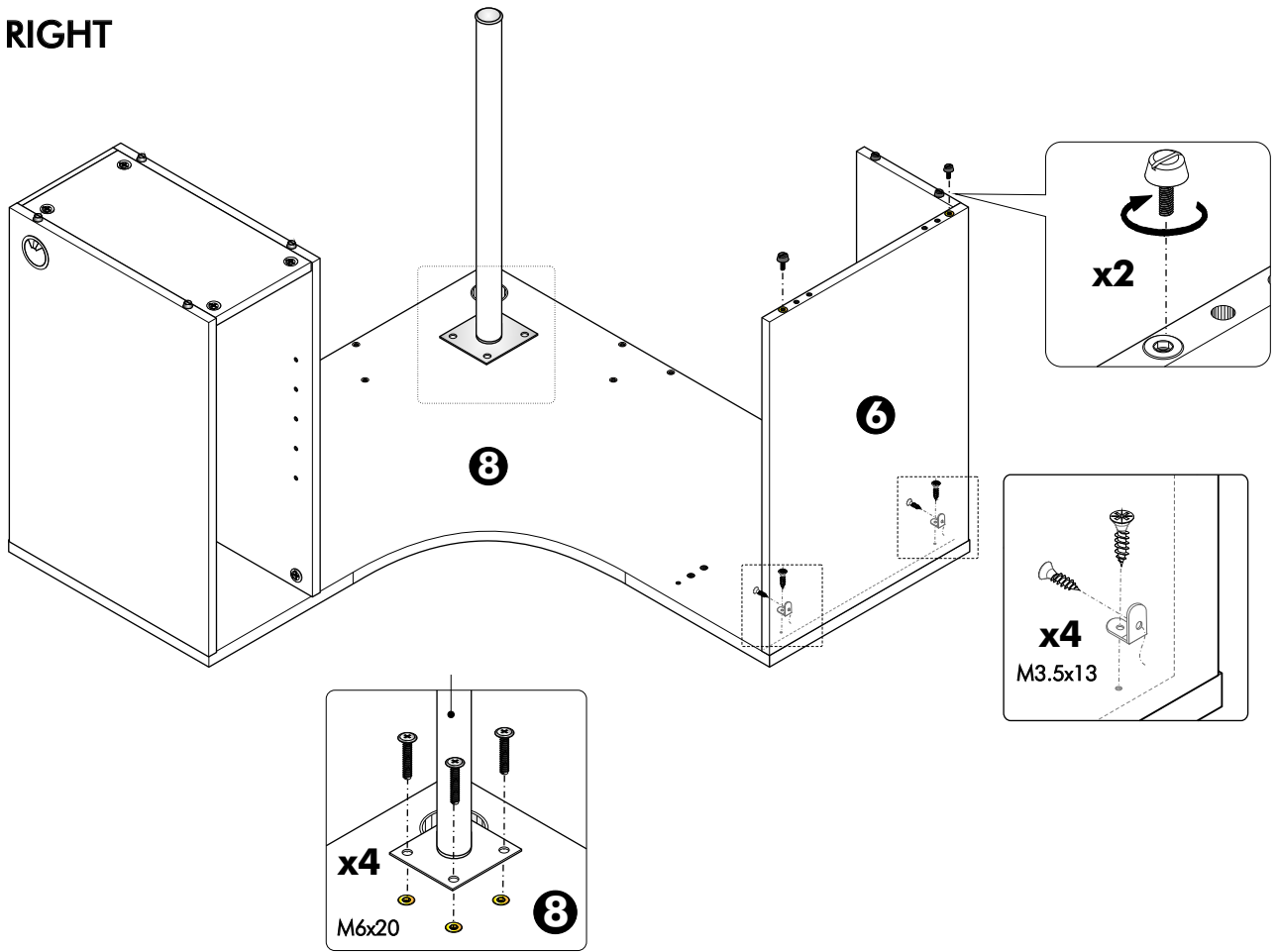

7. RIGHT

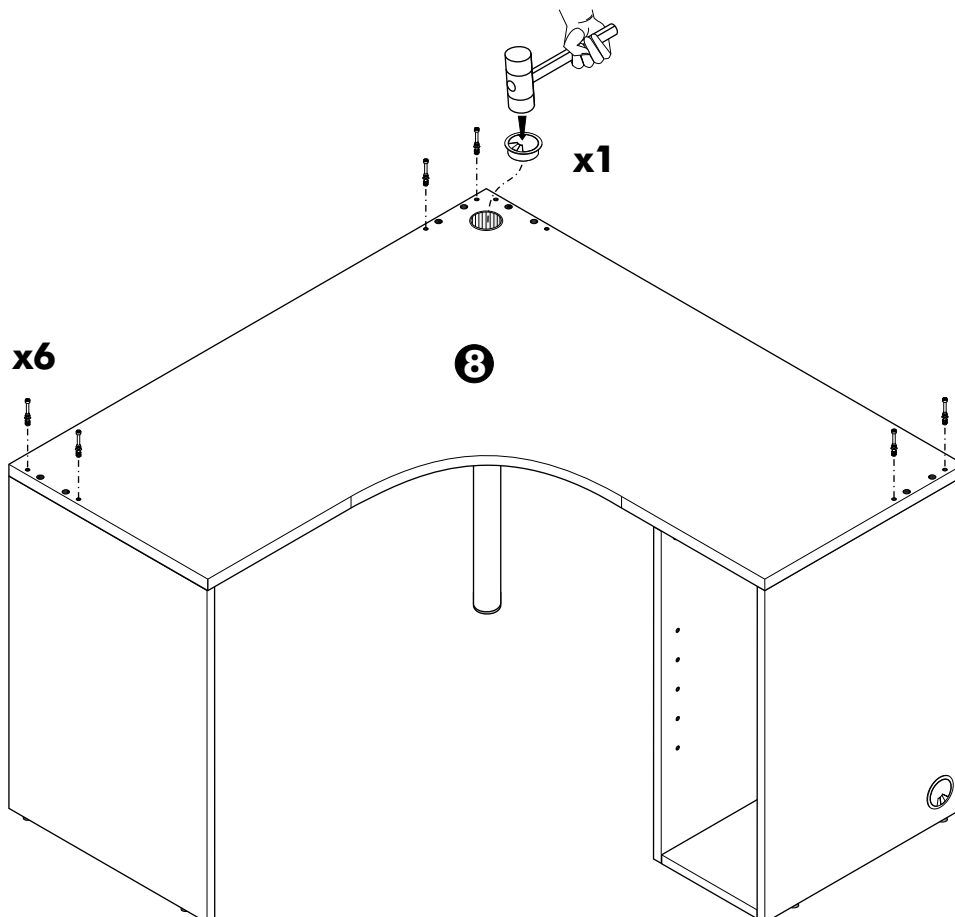

8. RIGHT

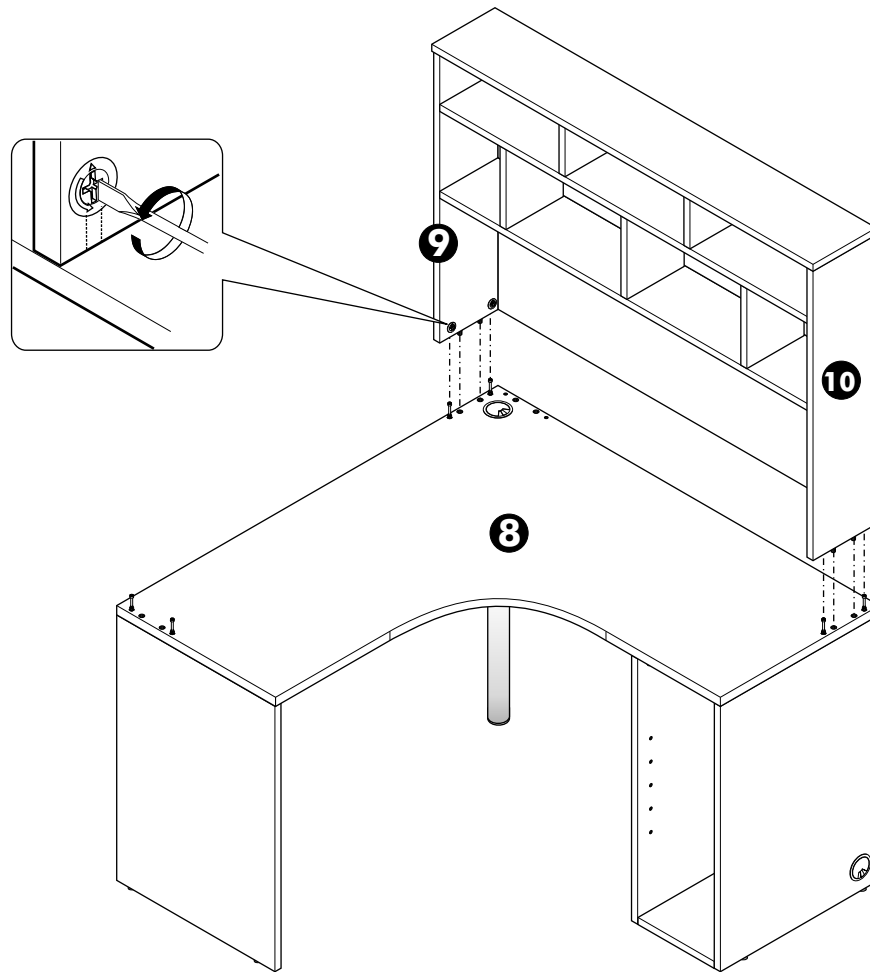

9. RIGHT

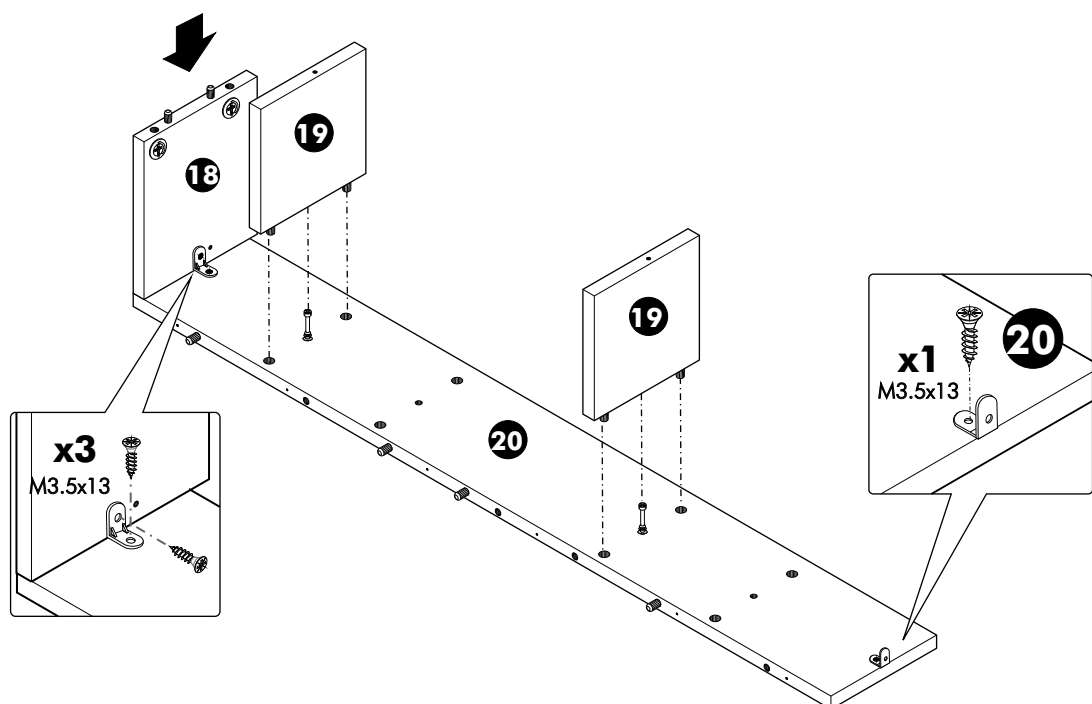

10. RIGHT

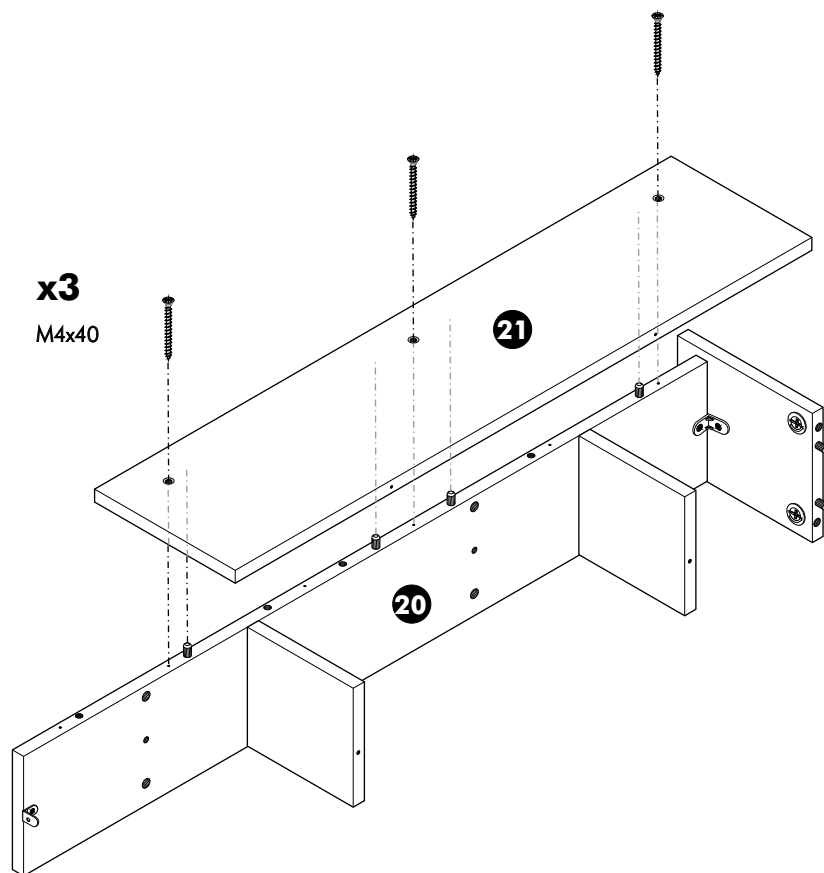

11. RIGHT

8 + 17 + 19 + 21

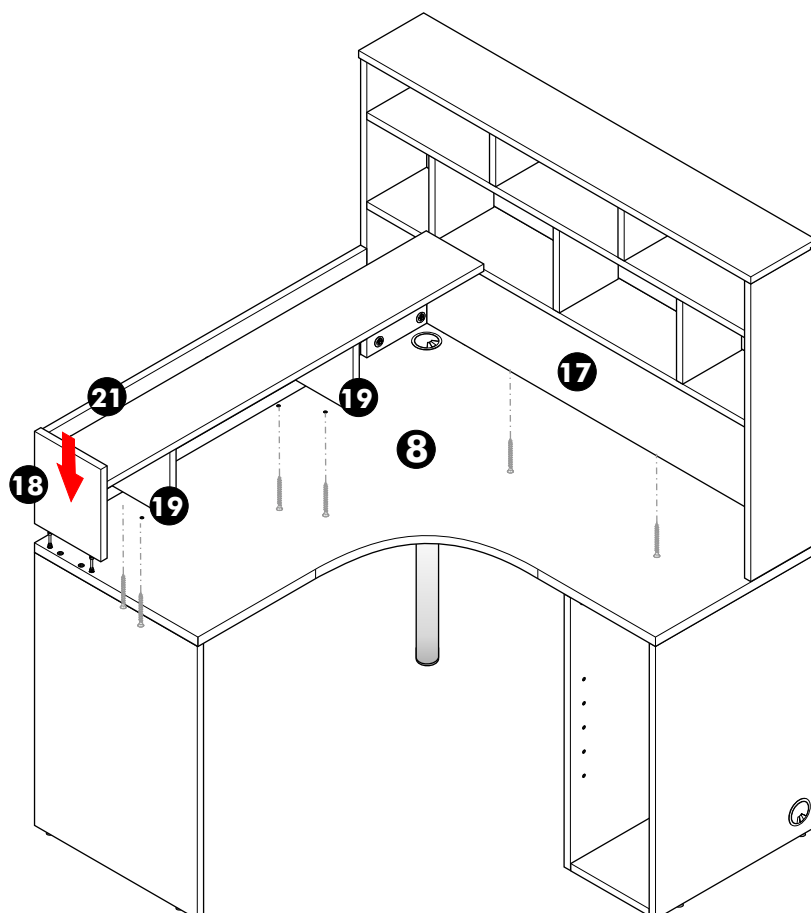
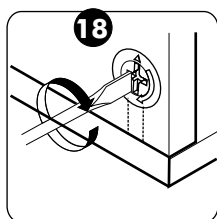
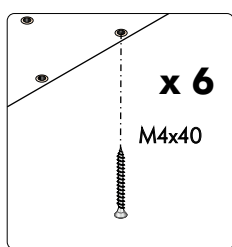

12. RIGHT

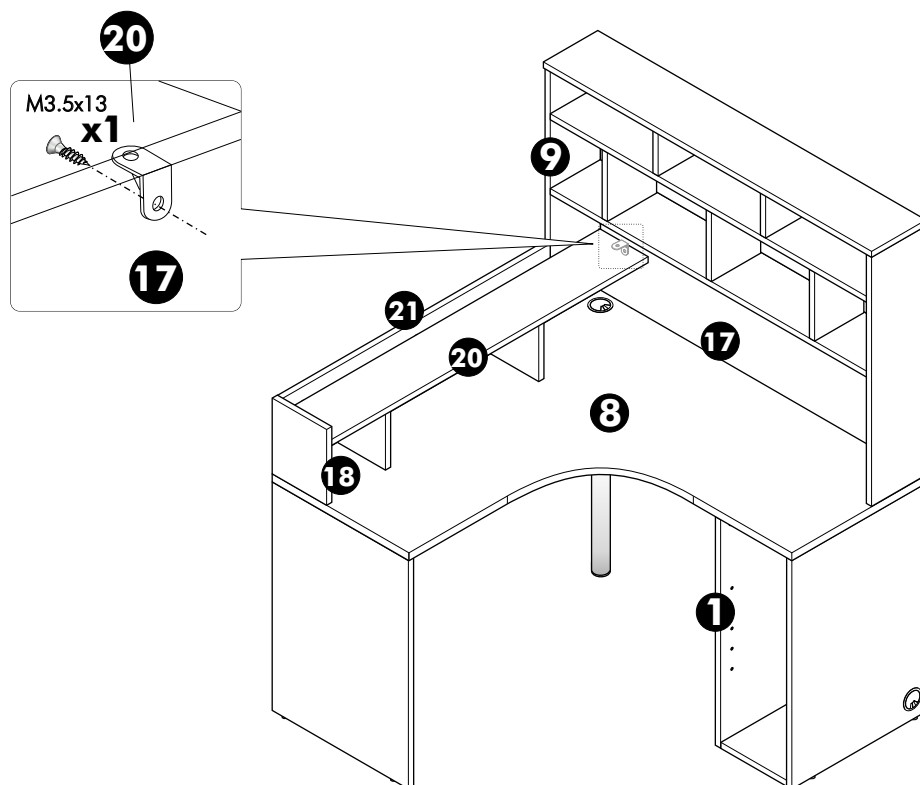

13. RIGHT

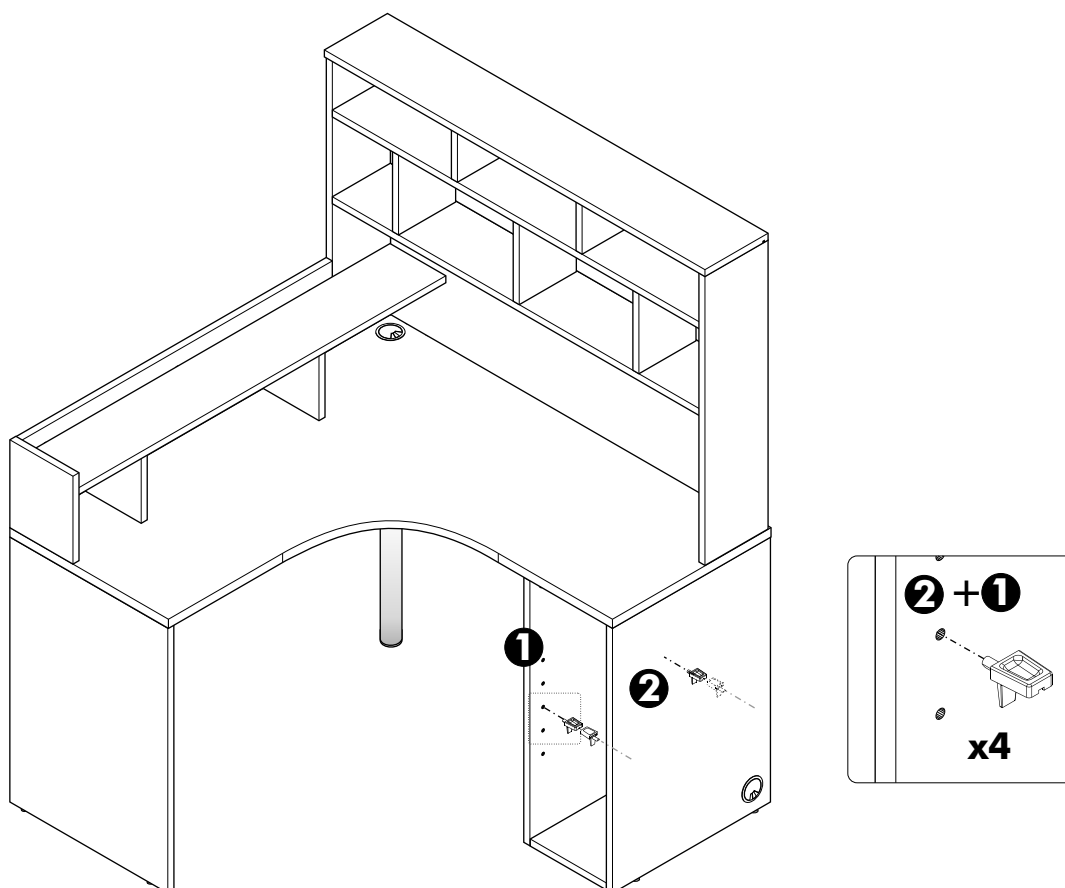

14. RIGHT

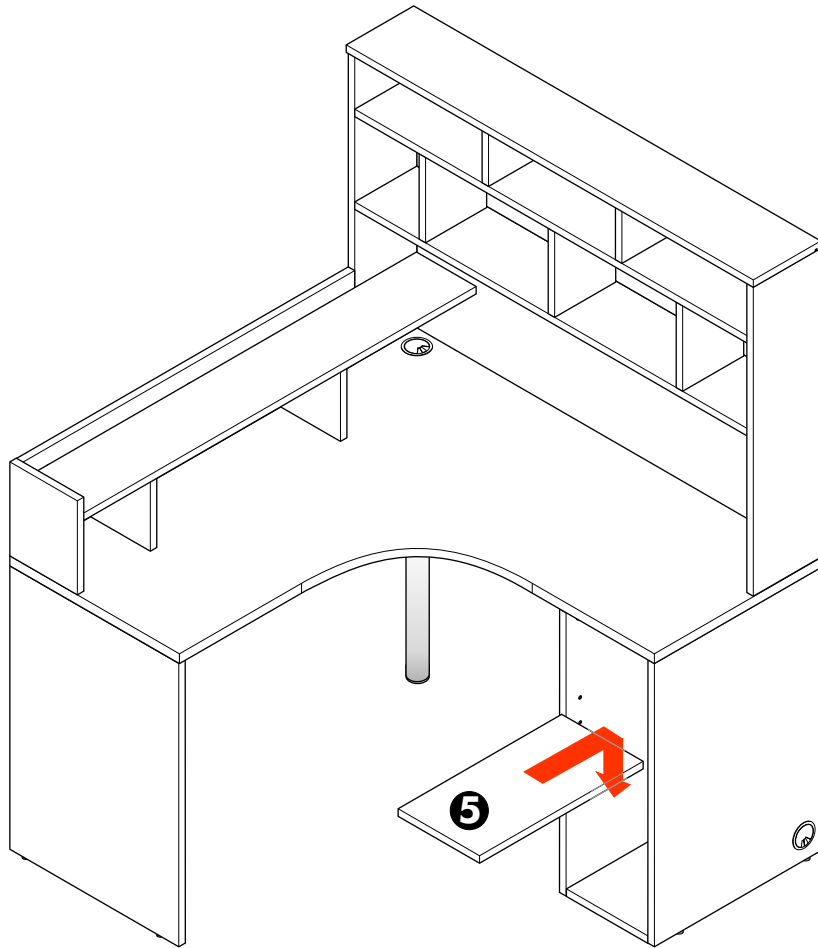

15. RIGHT

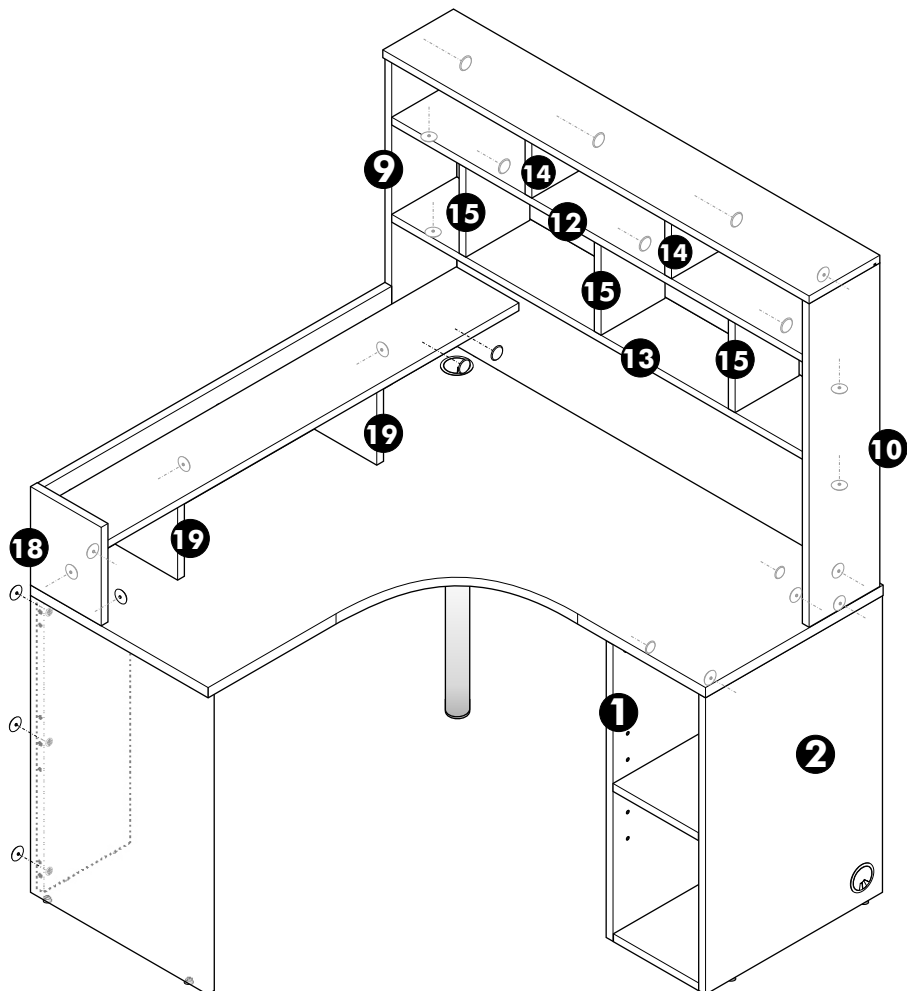
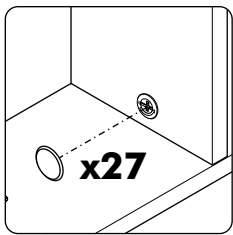

16. RIGHT

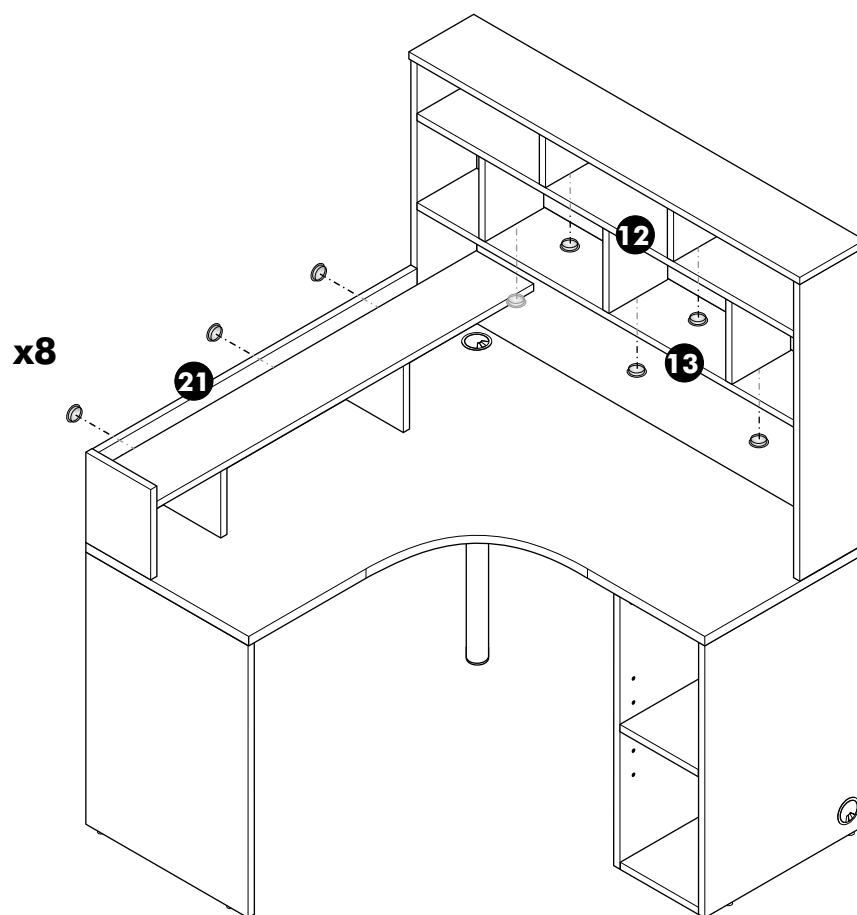

17. RIGHT

