

# CLEVERO-P

Working table 100 cm.

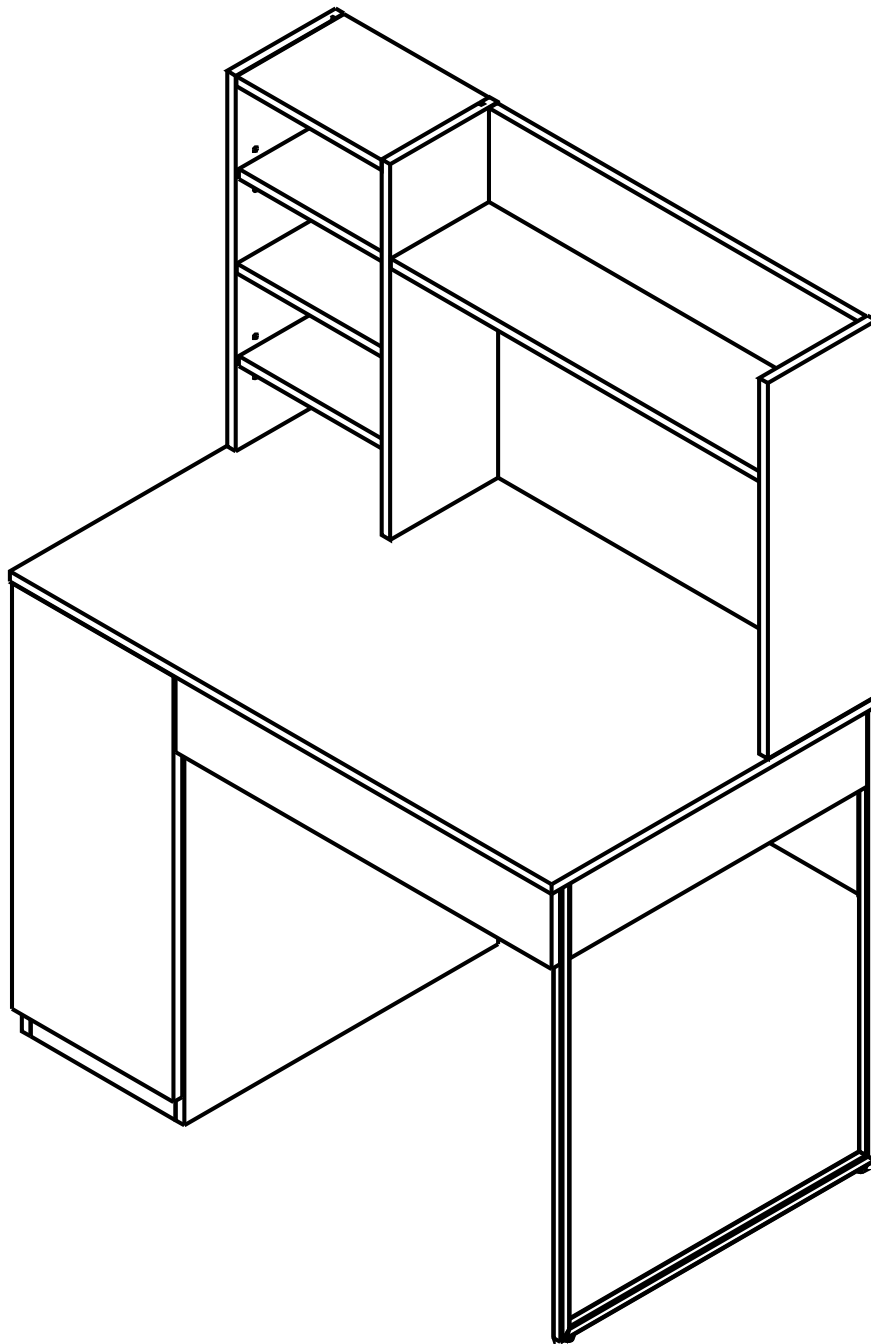

# CONNECT SYSTEM

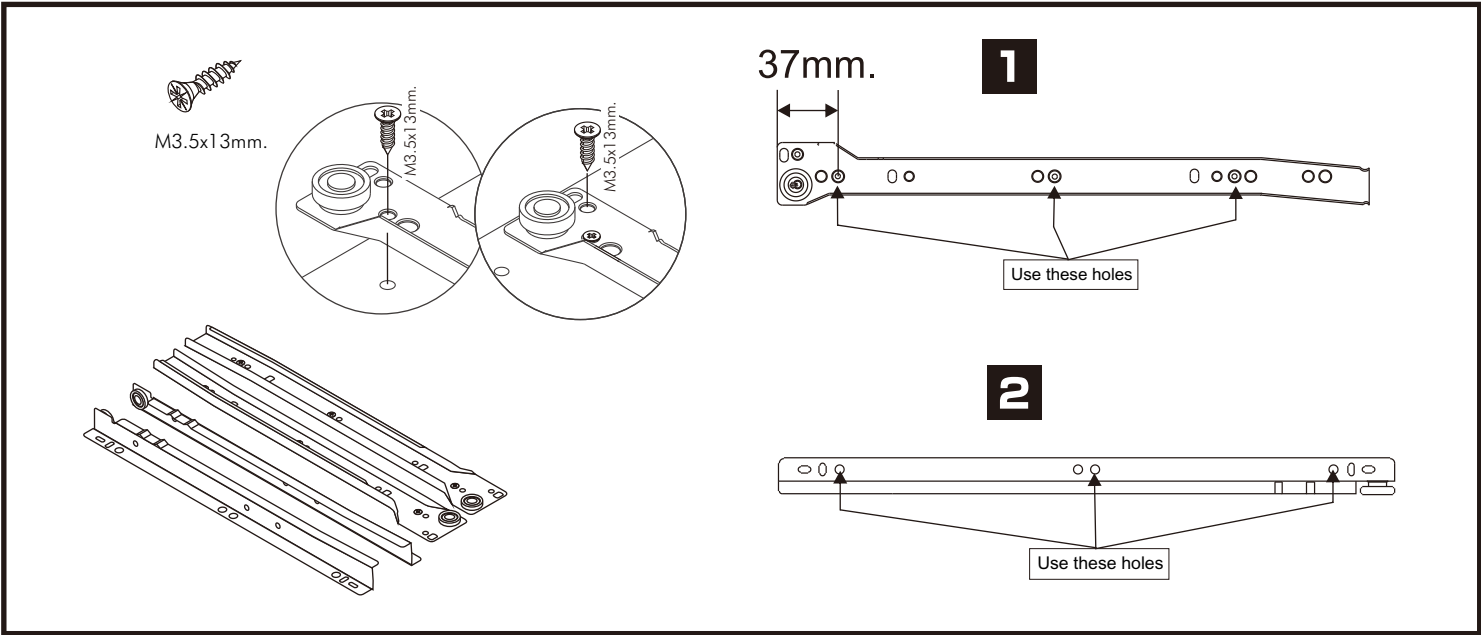
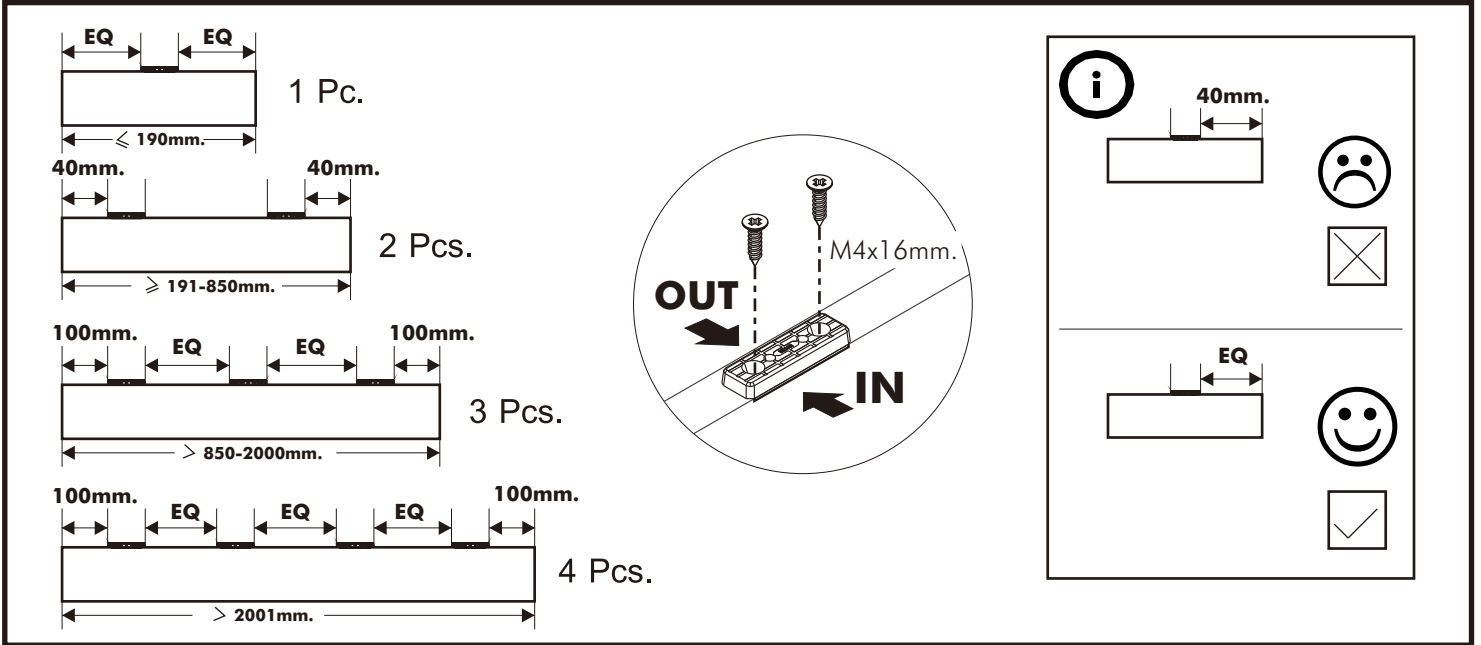
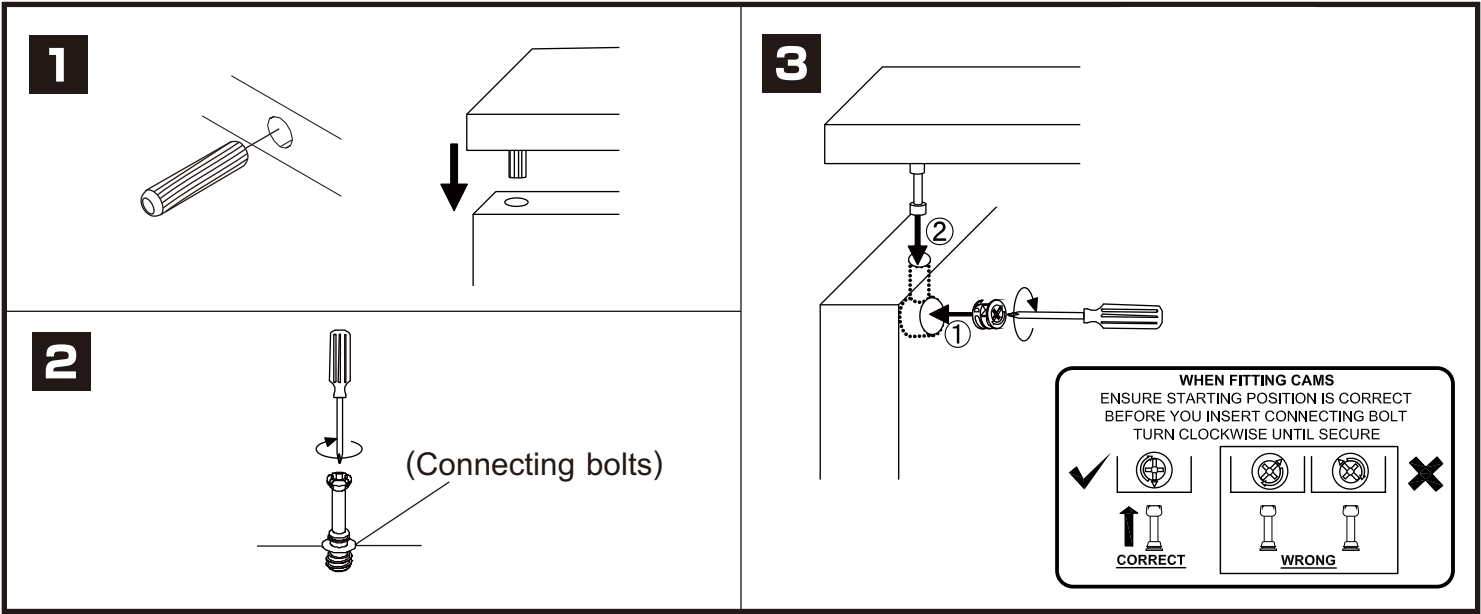

# CONNECT SYSTEM

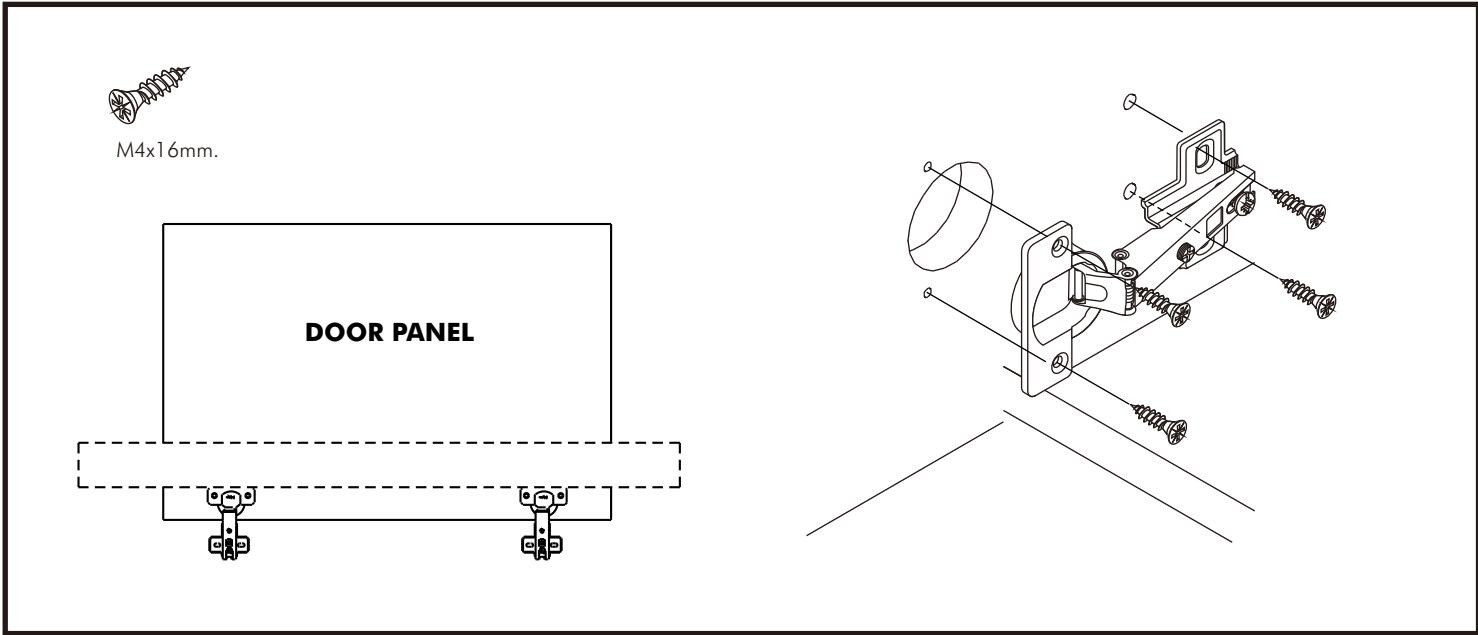
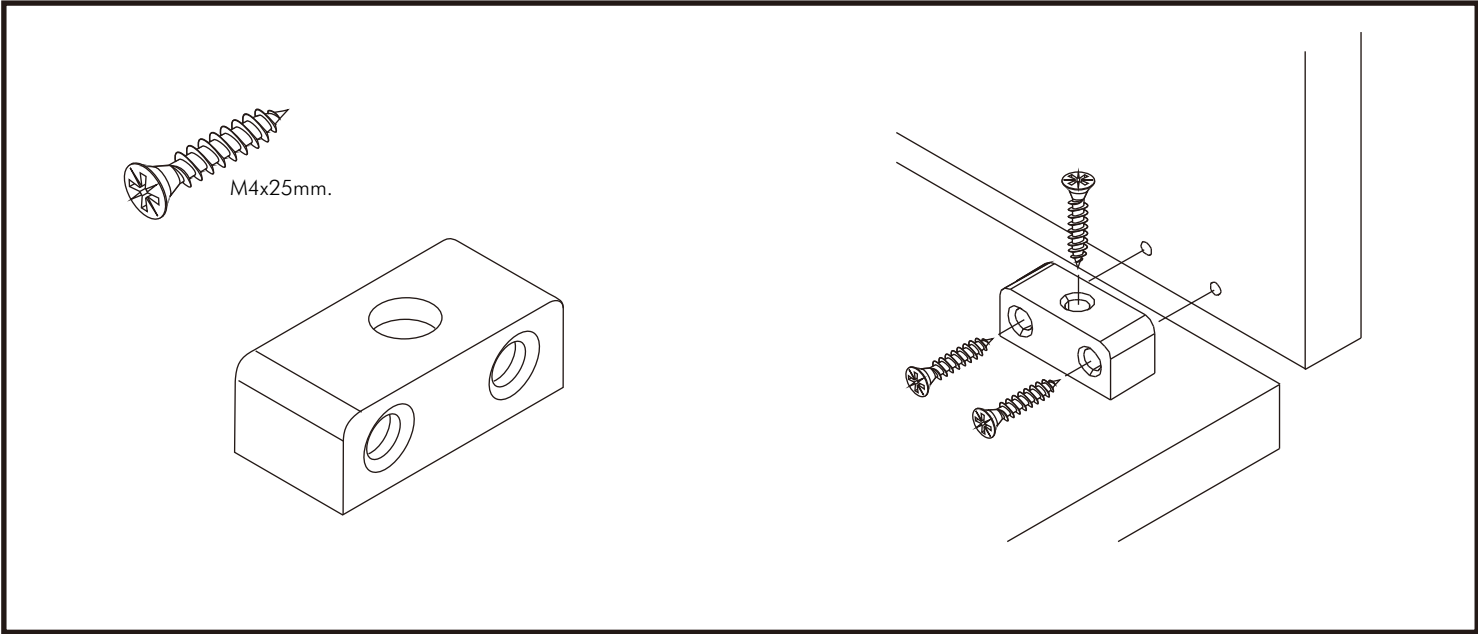

# HARDWARE

## -BODY SET

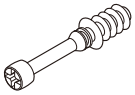

**x 33**



**x 35**

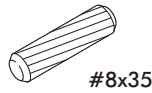

**x 56**

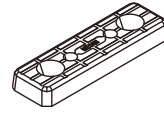

**x 4**



**x 2**



M4x16mm.

**x 15**

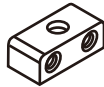

**x 4**

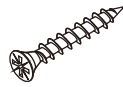

M4x25mm.

**x 15**

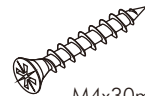

M4x30mm.

**x 4**



**x 2**



**x 19**

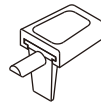

**x 12**

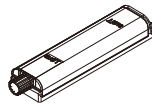

**x 1**

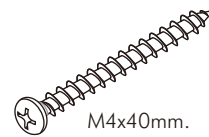

M4x40mm.

**x 4**

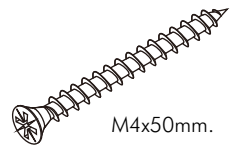

M4x50mm.

**x 9**



M4x16mm.

**x 6**

## -DRAWER SET

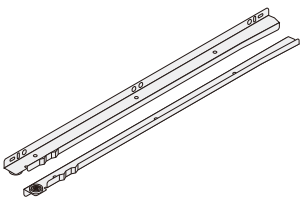

**x 1**



M3.5x13mm.

**x 12**

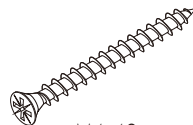

M4x40mm.

**x 12**



M6x23mm.

**x 3**

## -DOOR SET

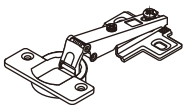

**x 2**



M4x16mm.

**x 8**



**x 3**

**1.**

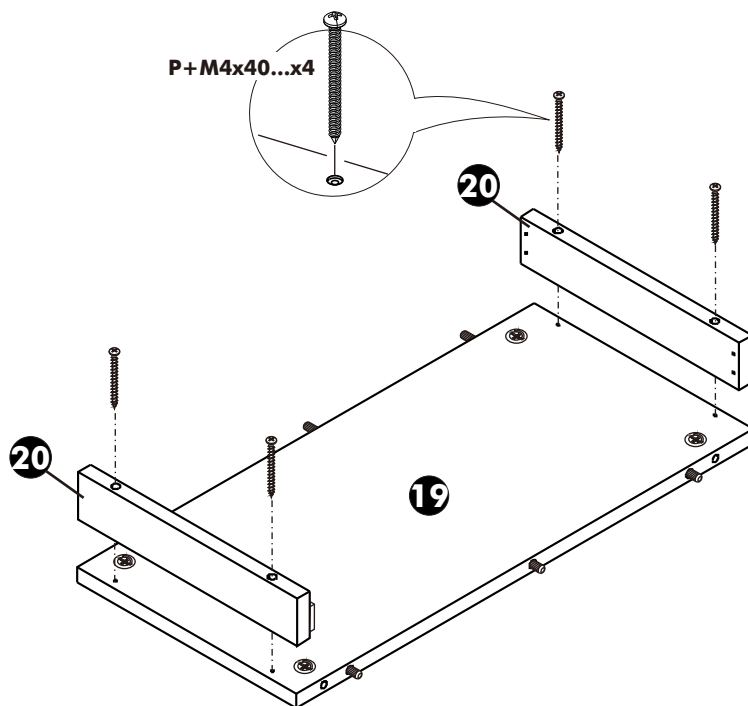

**2.**

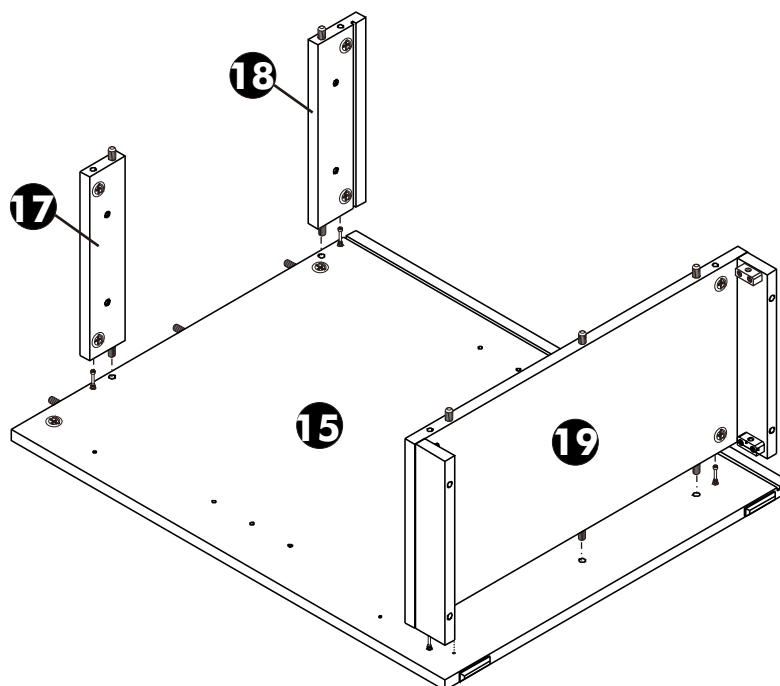

**3.**

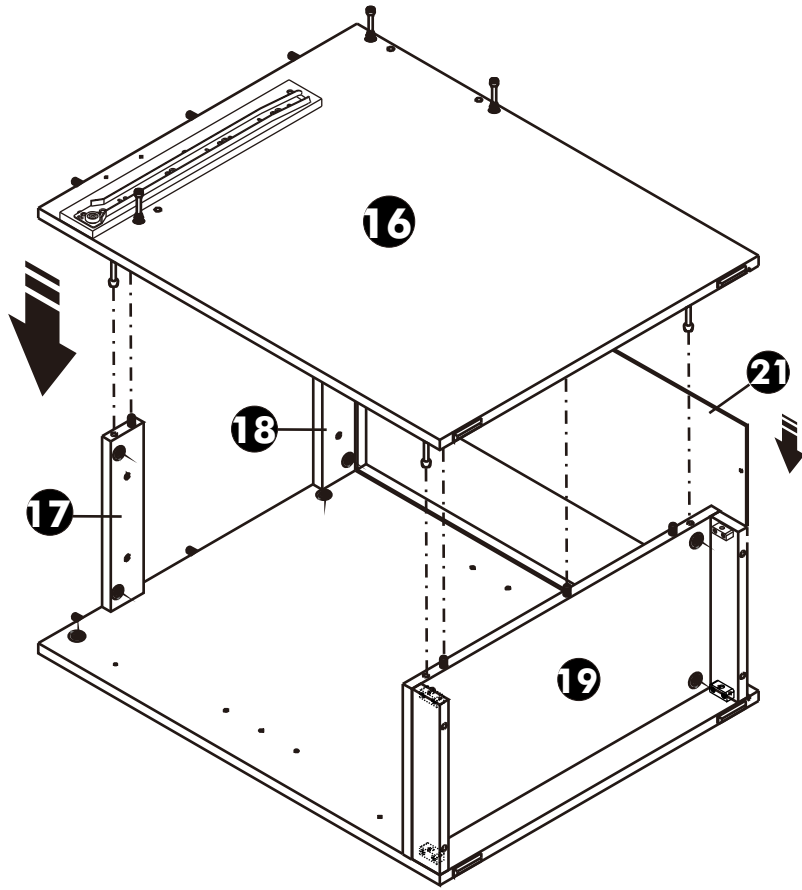

**4.**

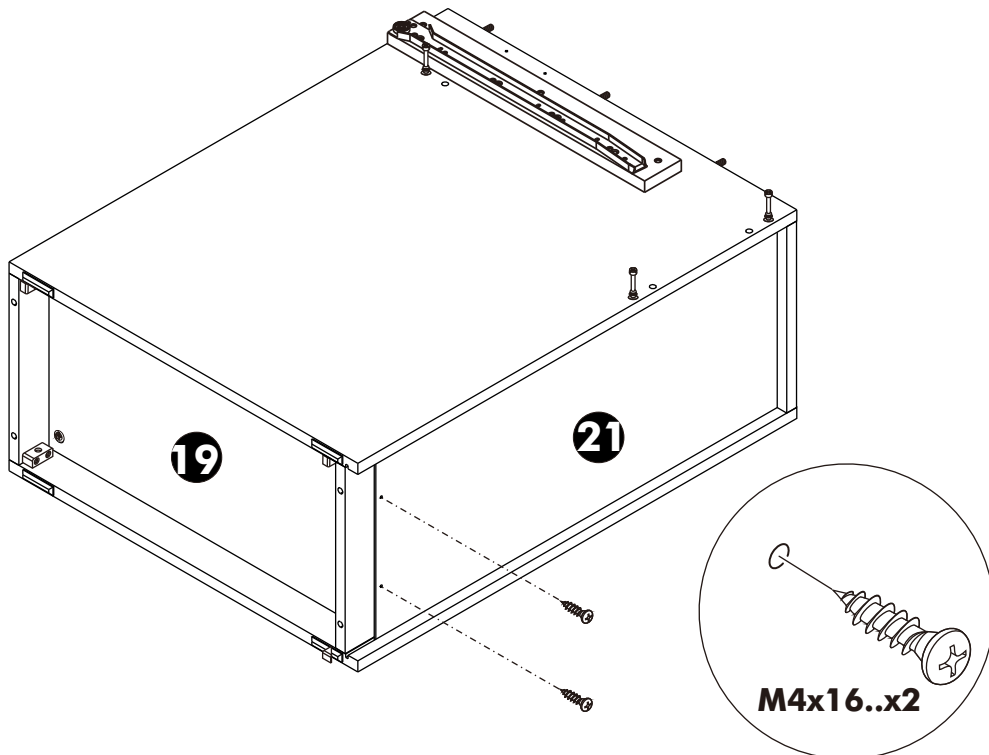

5.

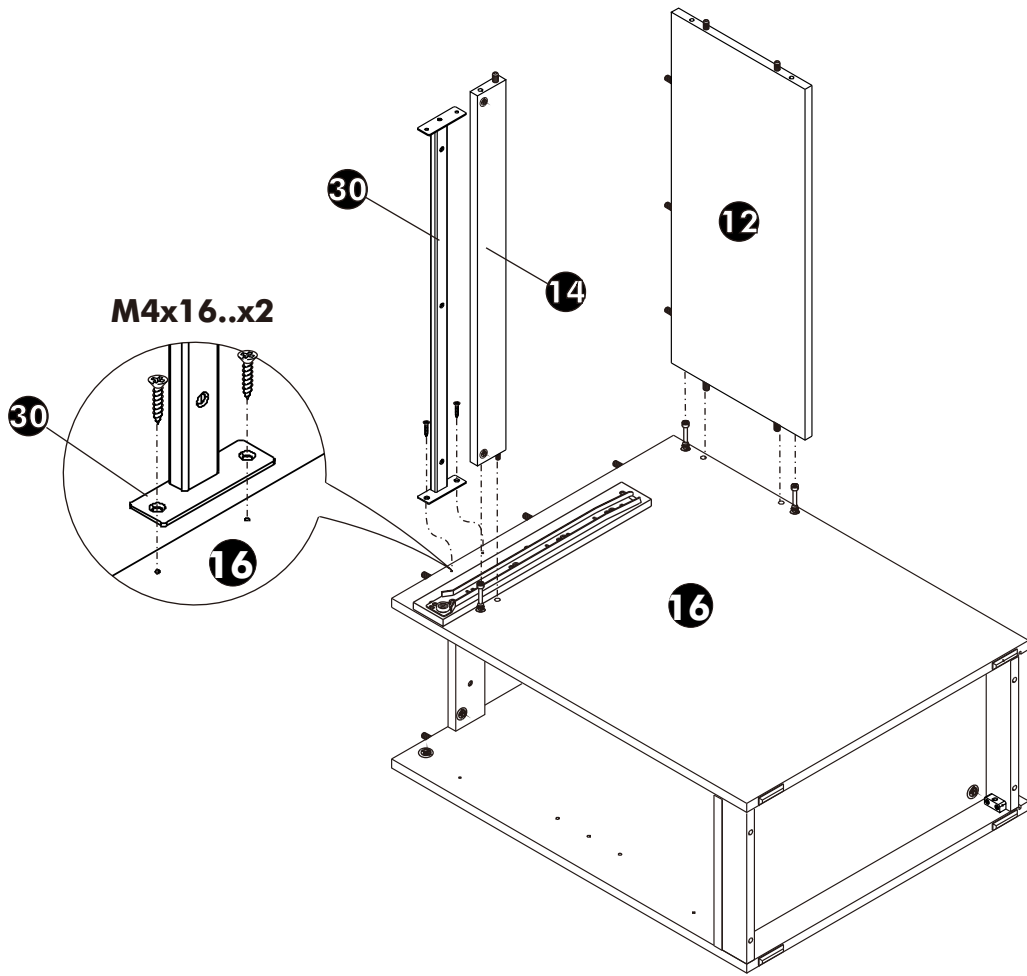

6.

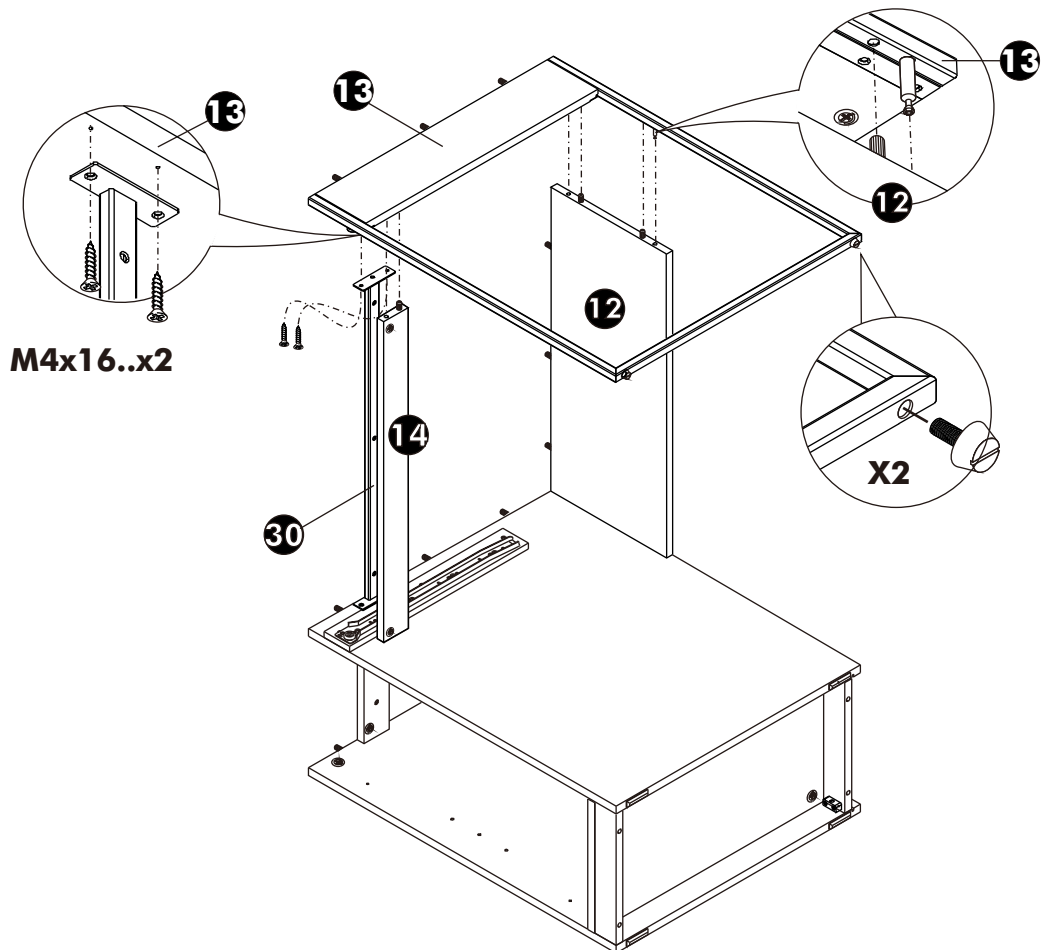

**7.**

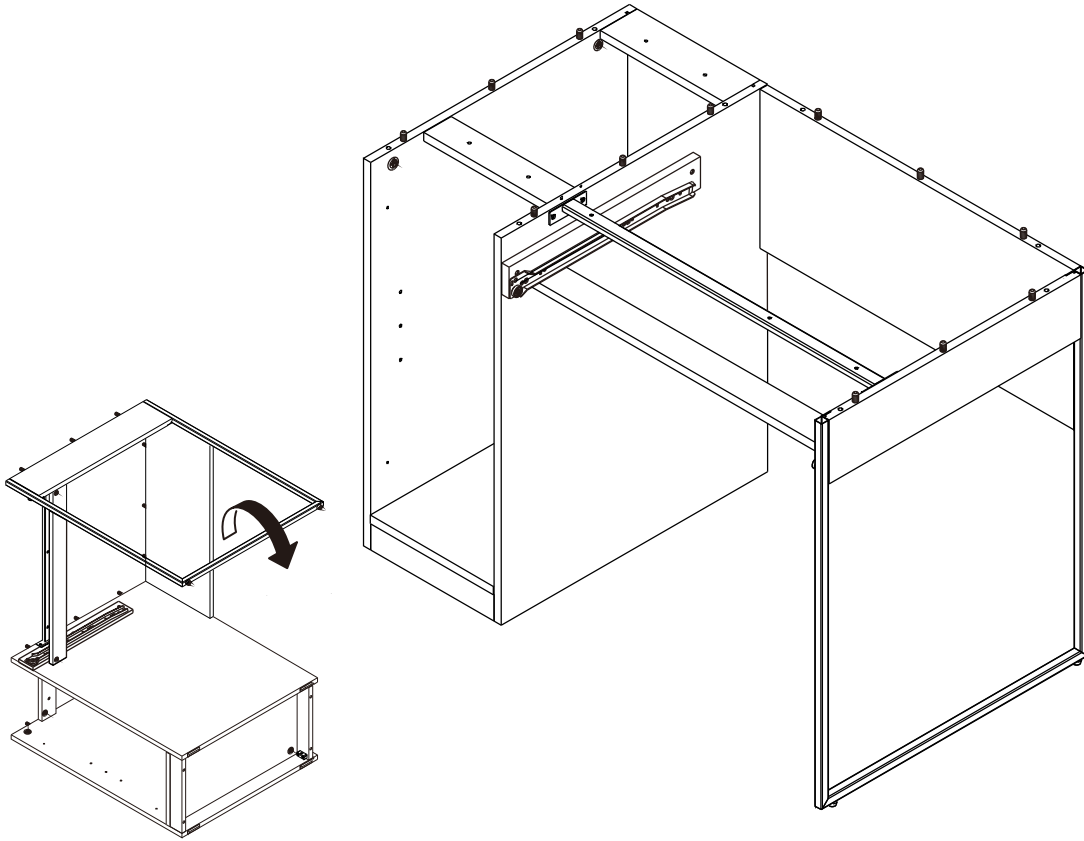

**8.**

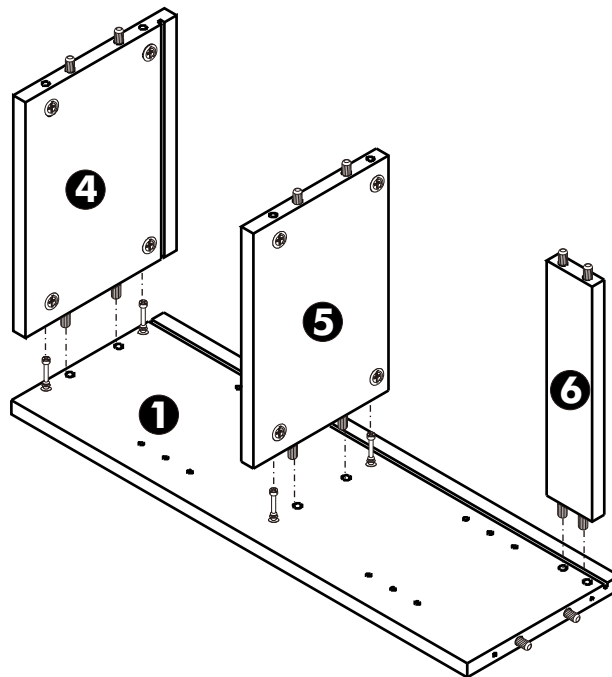

**9.**

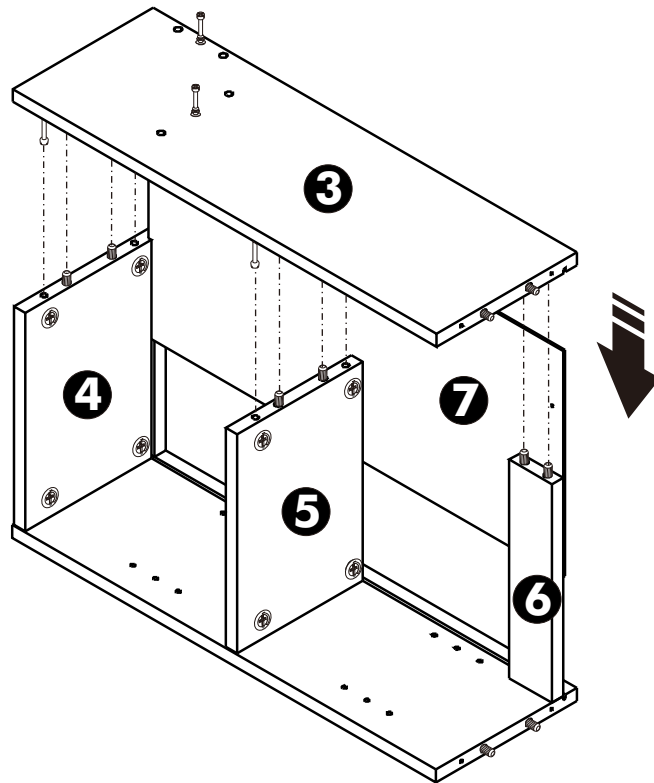

**10.**

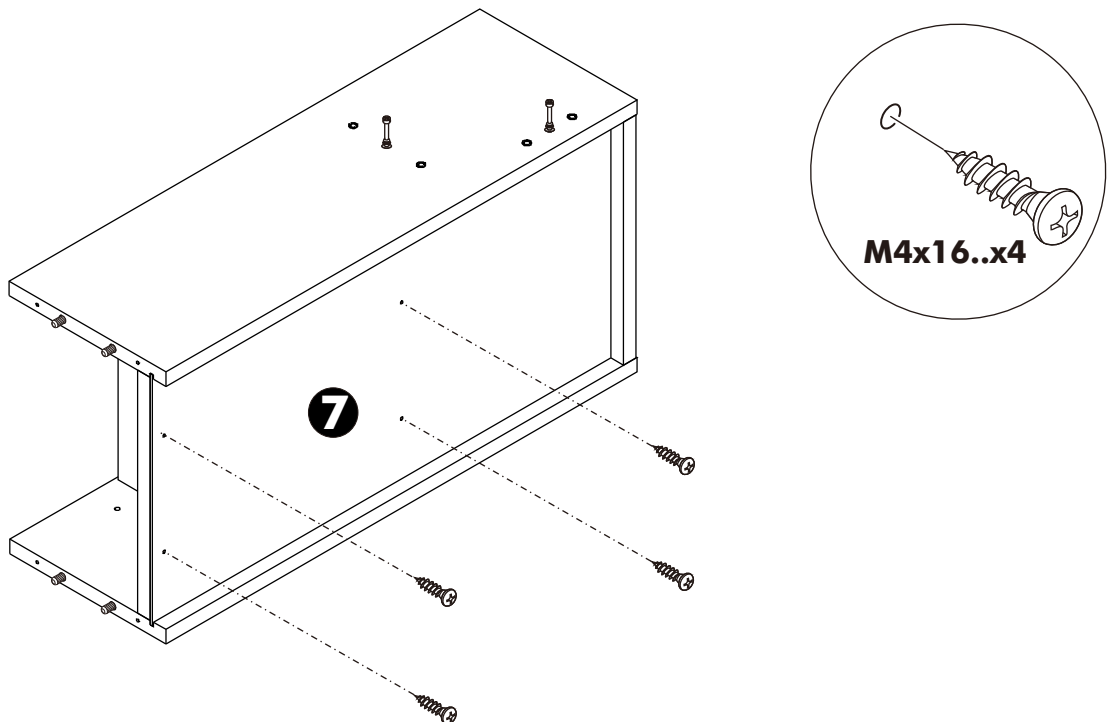

**11.**

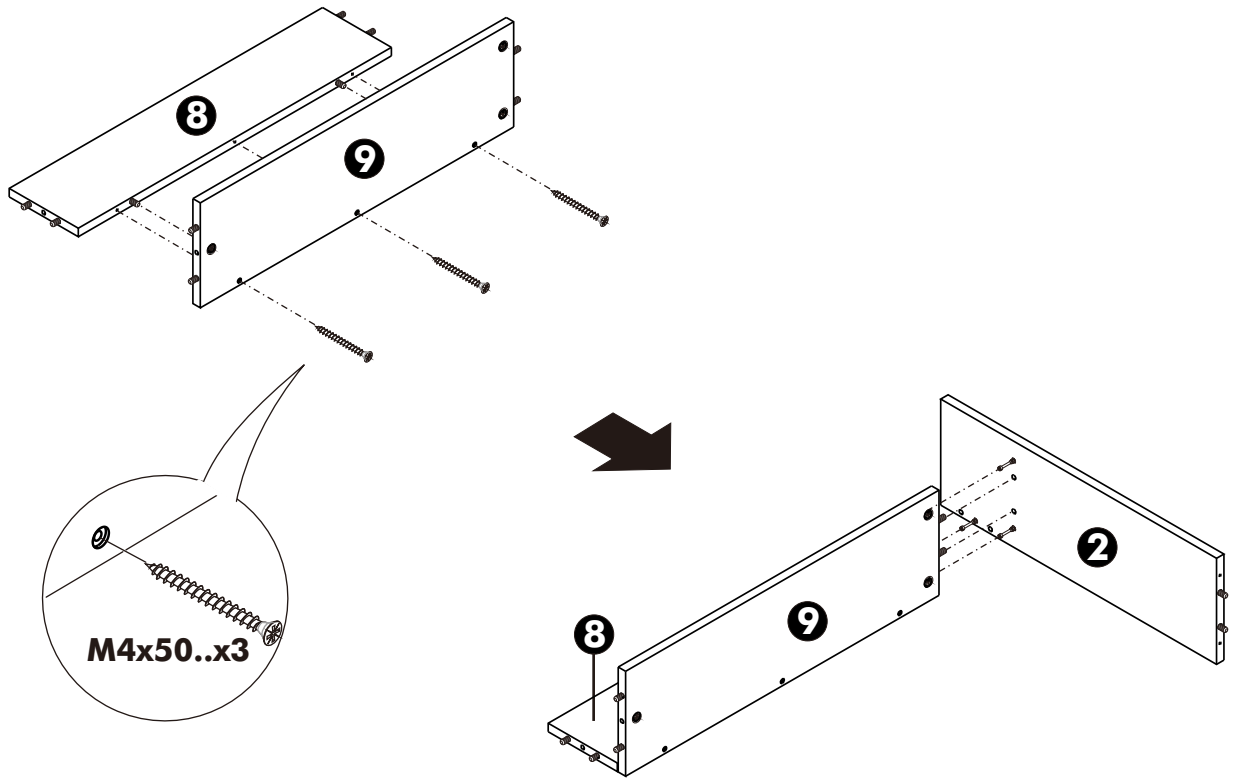

**12.**

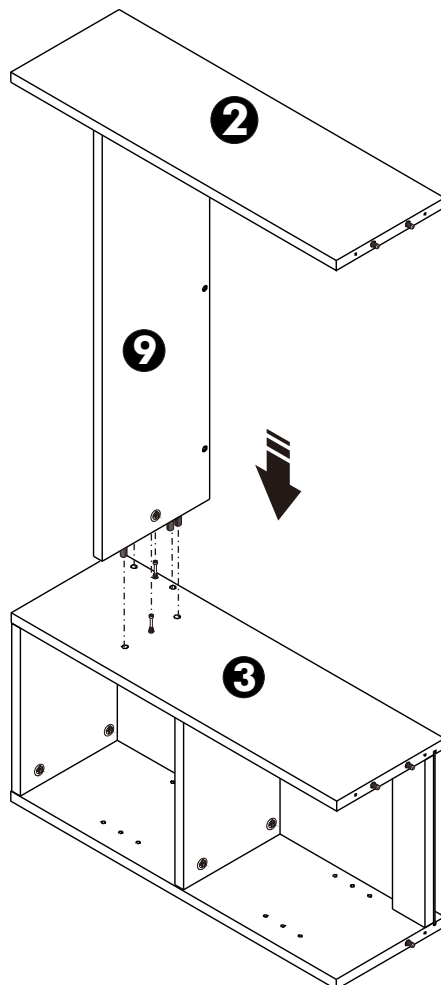

**13.**

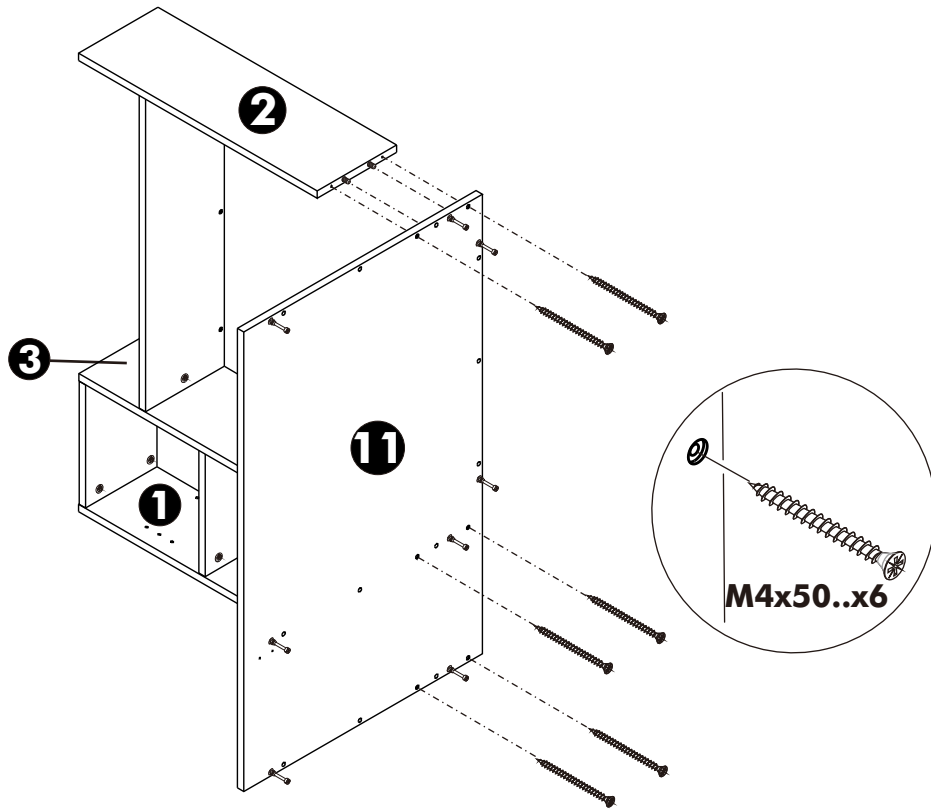

**14.**

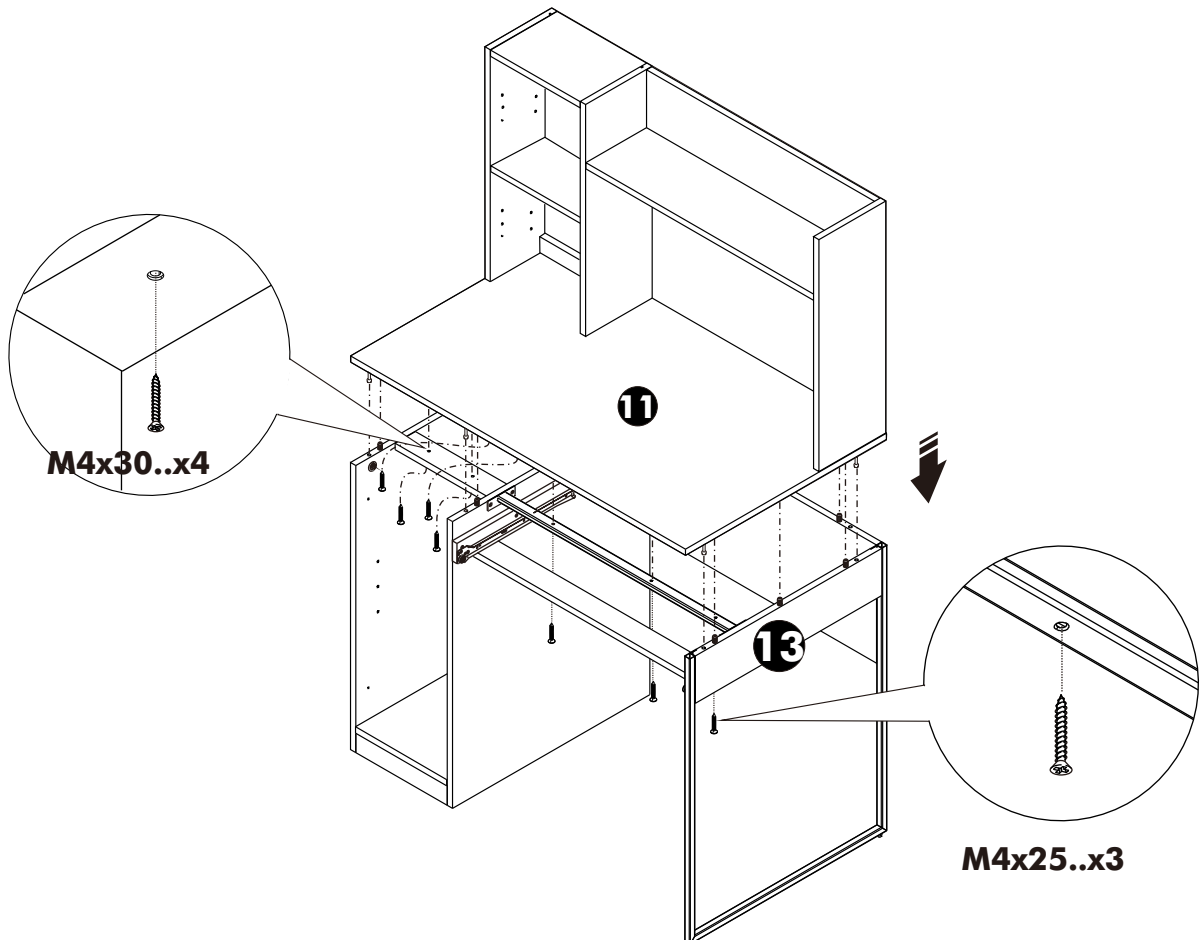

**15.**

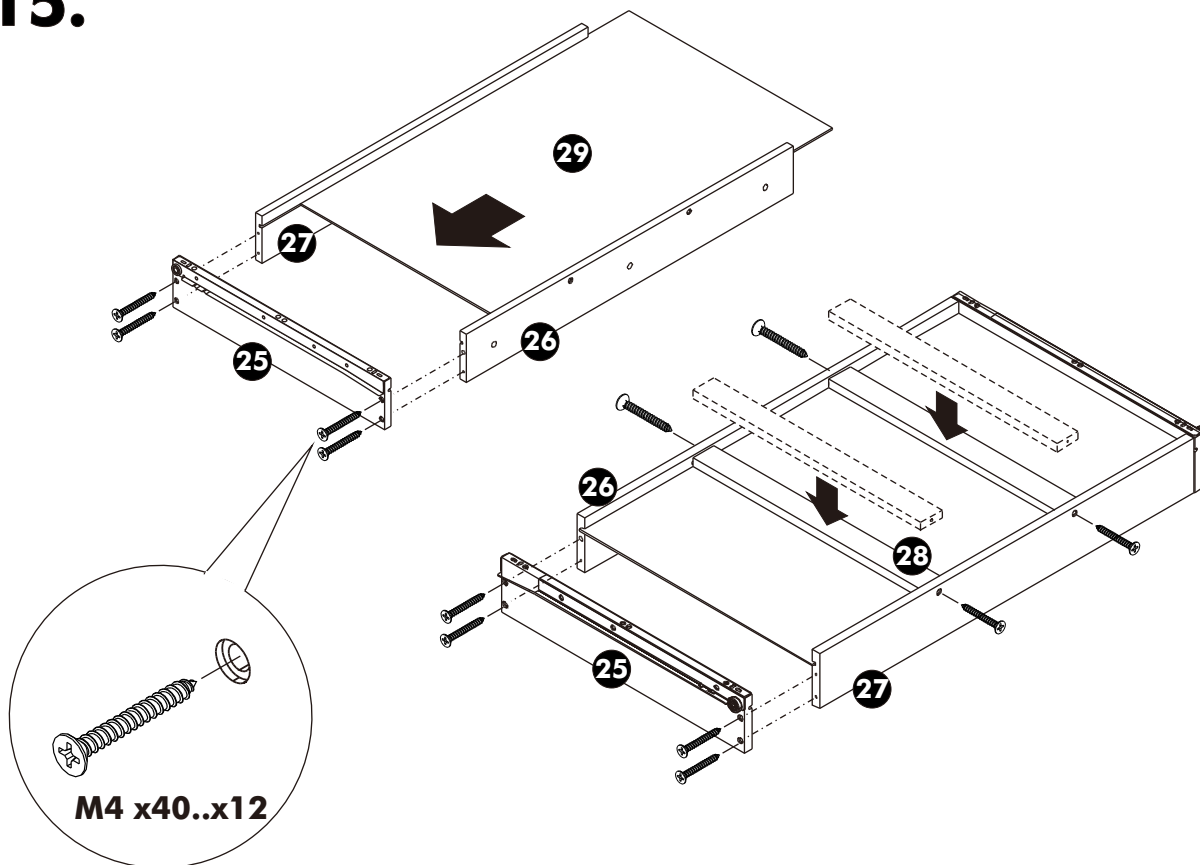

**16.**

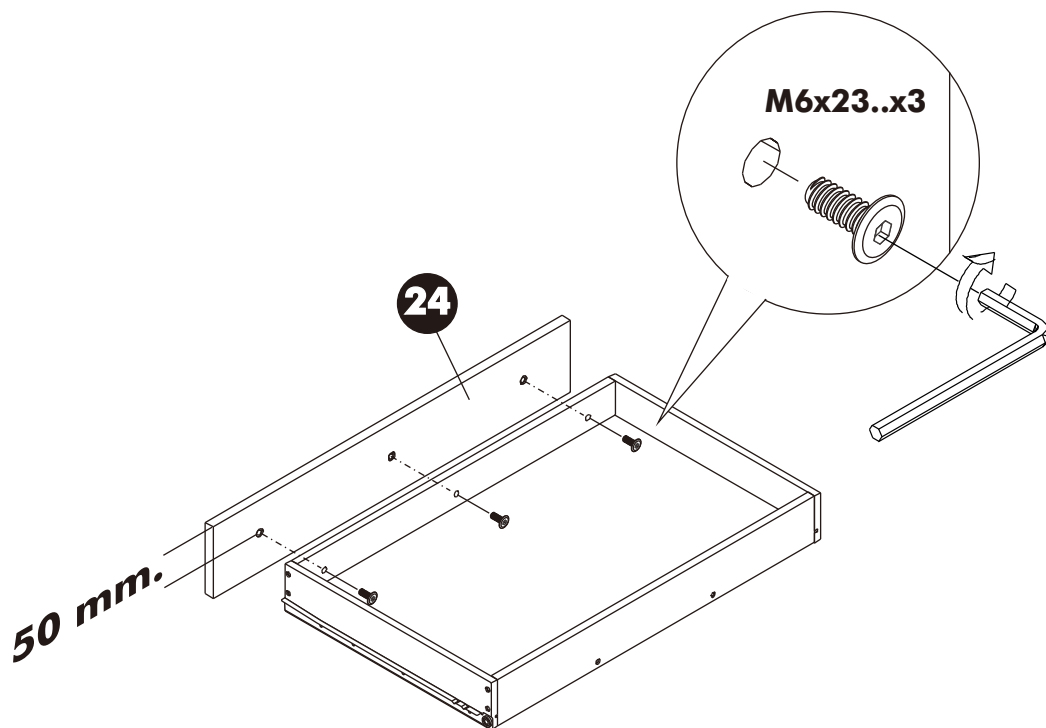

**17.**

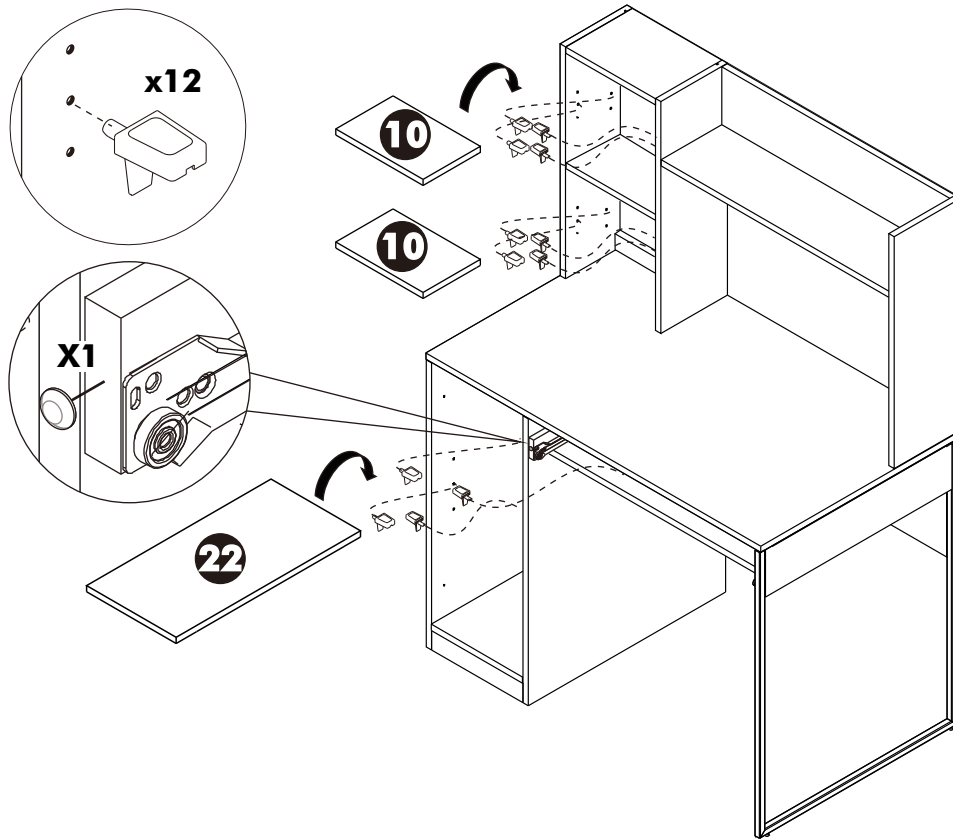

**18.**

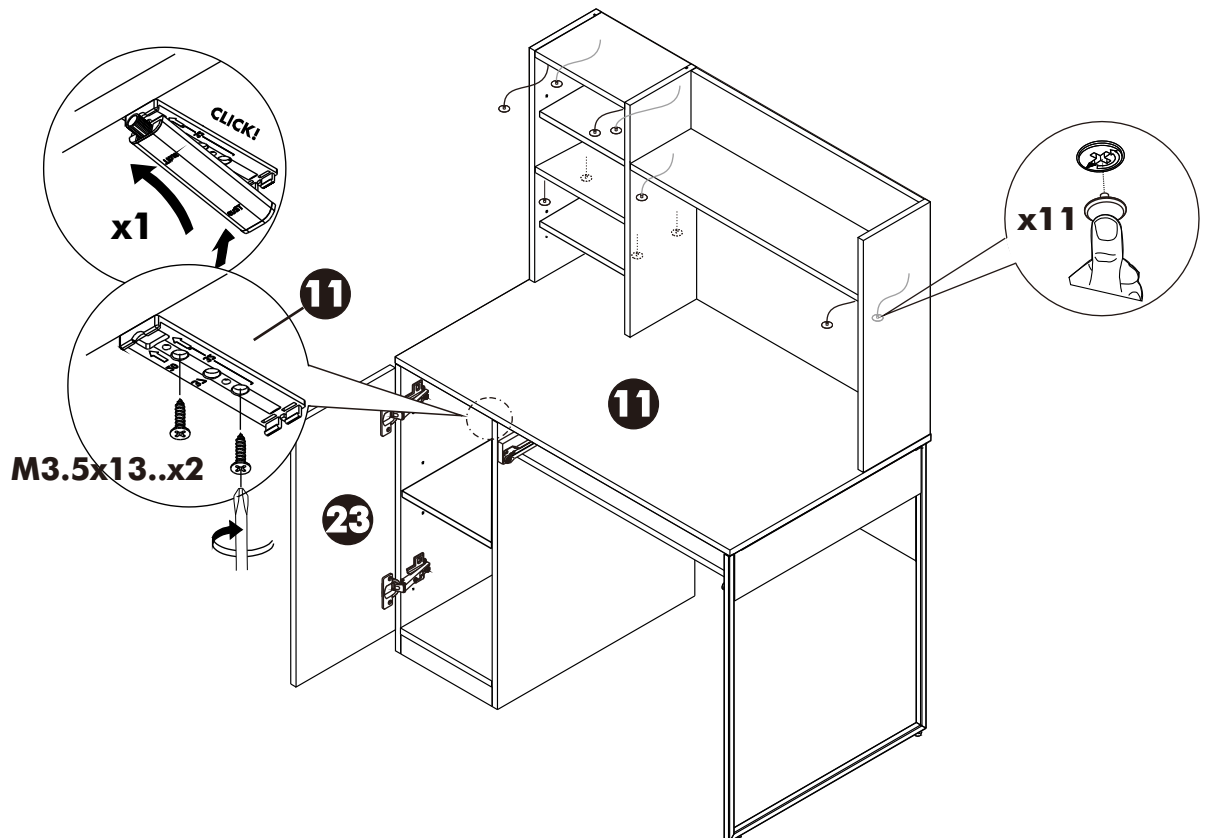

**19.**

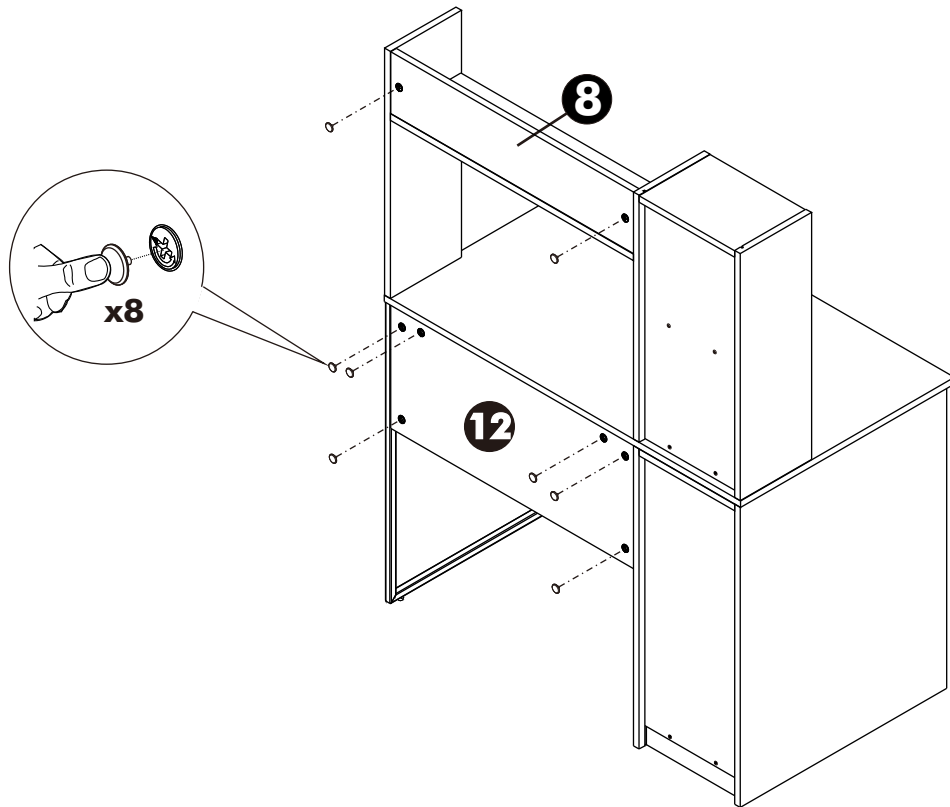

**20.**

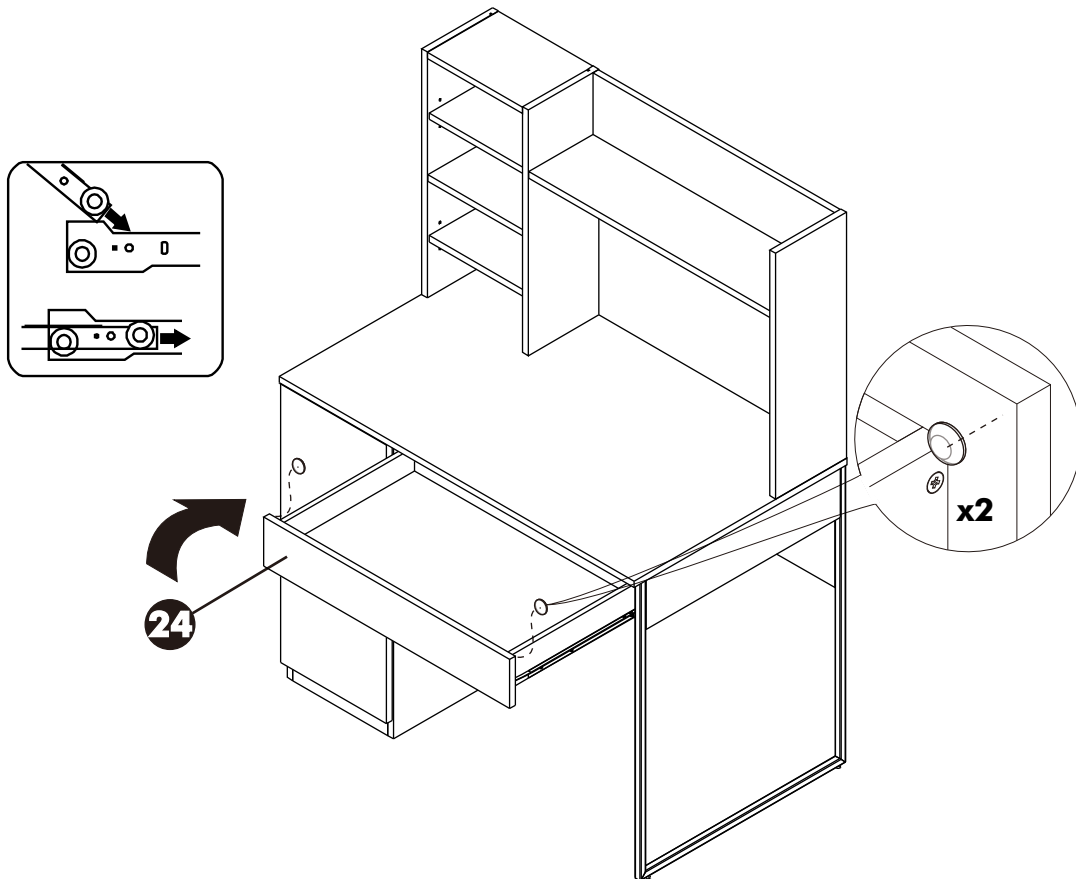

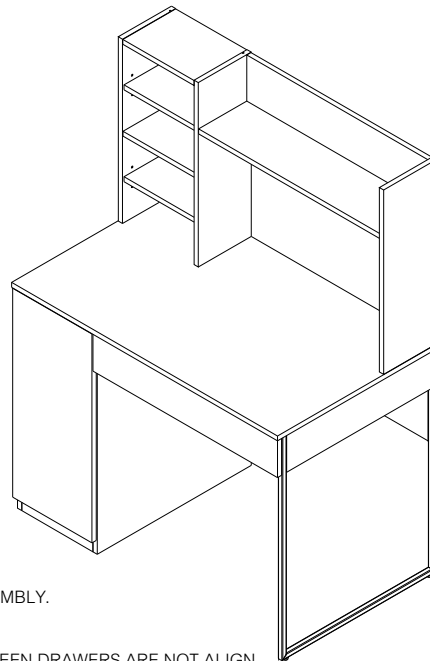
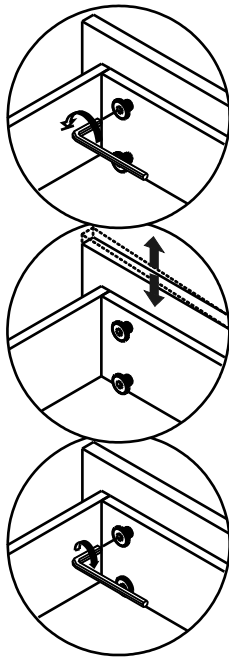

AFTER FINISHED ASSEMBLY.

INCASE OF GAP BETWEEN DRAWERS ARE NOT ALIGN.  
PLEASE ADJUST AS BELOW.

1. LOOSE SCREW A LITTLE BIT.
2. THEN MOVE FRONT DRAWER TO ALINGMENT POSITION.
3. TIGHTEN SCREW.

