

# SPECTRUM

**Show Cabinet /45x200**

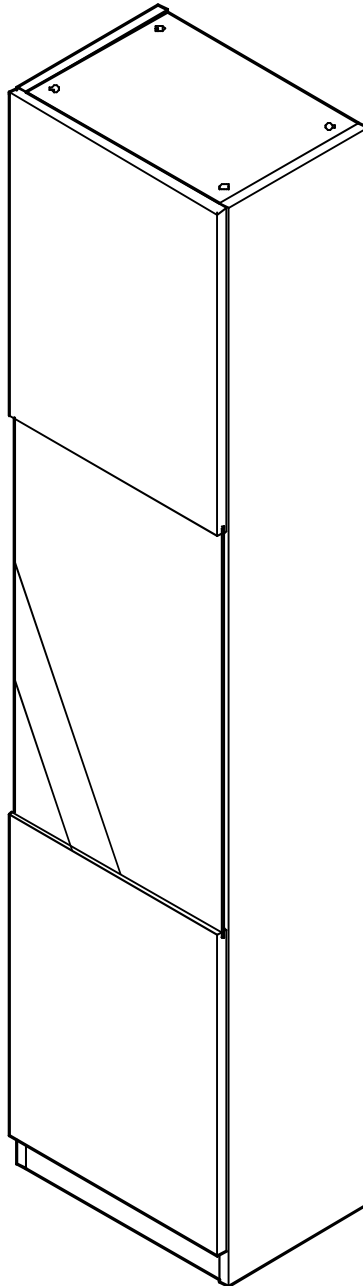

# CONNECT SYSTEM

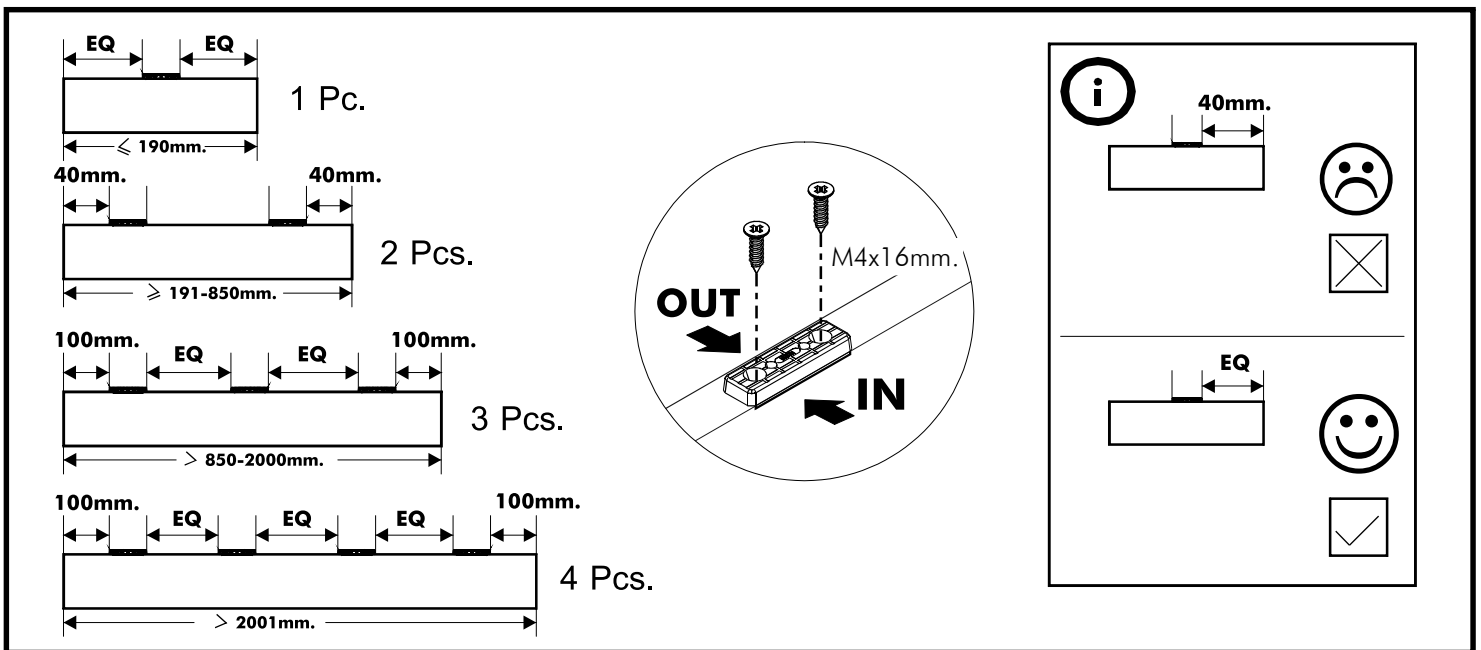
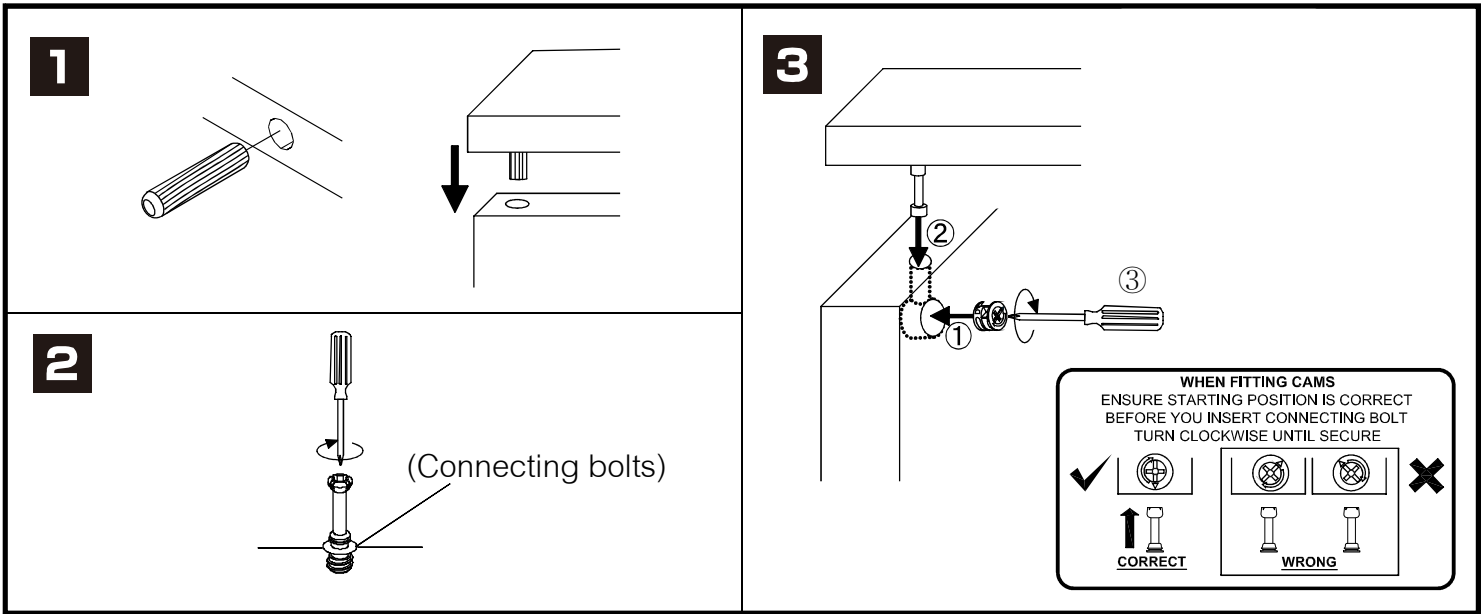

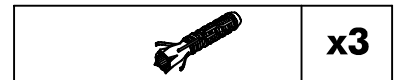
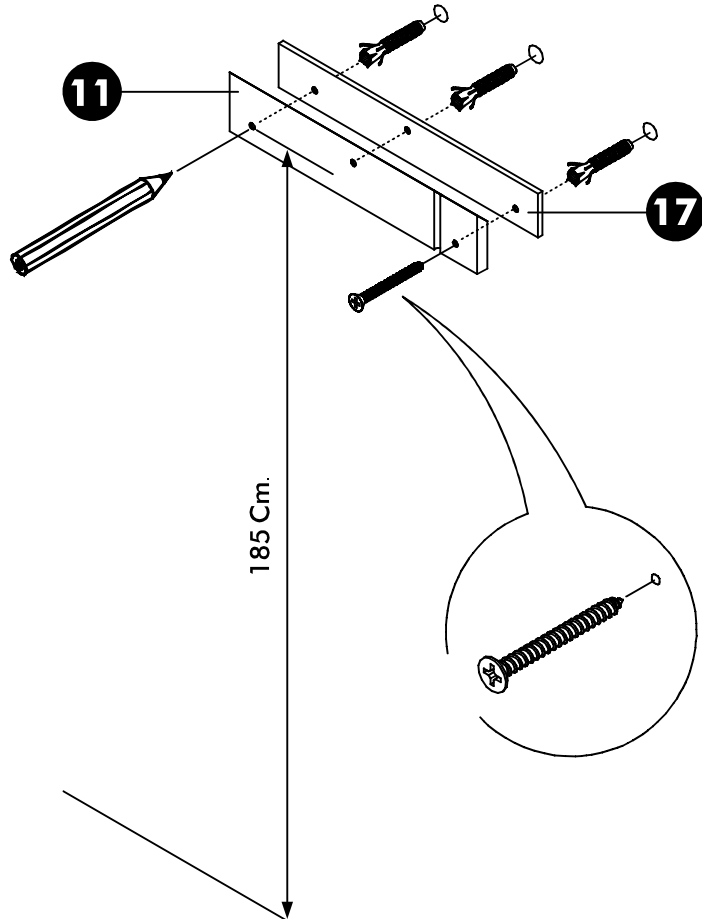
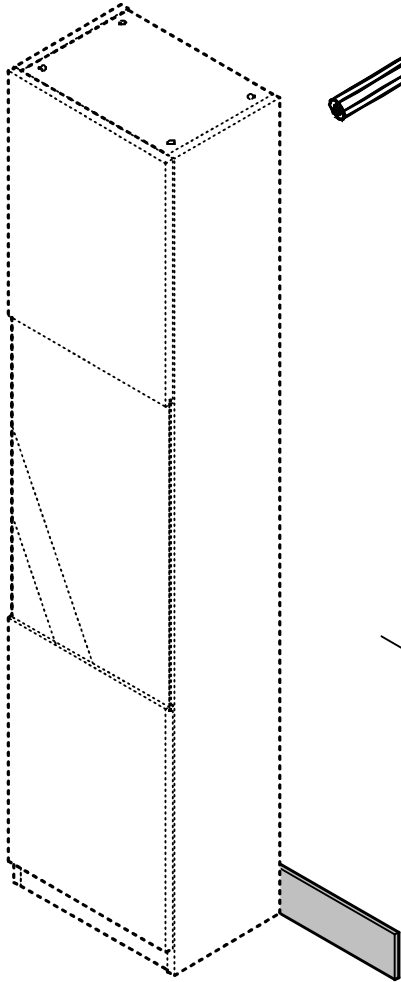

# HARDWARE



**x20**



**x18**

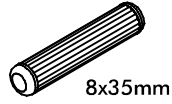

**x37**

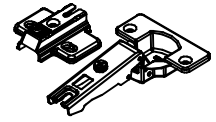

**x4**

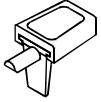

**x16**



**x8**

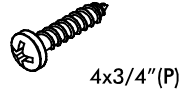

**x3**

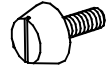

**x4**

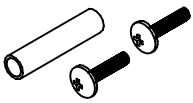

**x4**



**x1**



**x3**

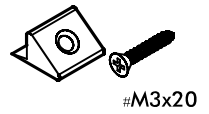

**x8**

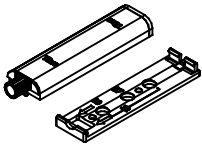

**x1**



**x2**



**x6**



**x2**



**x4**



**x16**

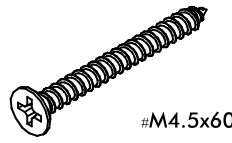

**x3**

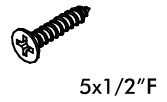

**x2**



**x2**

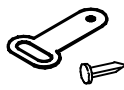

**x1/1**

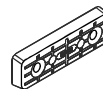

**x4**

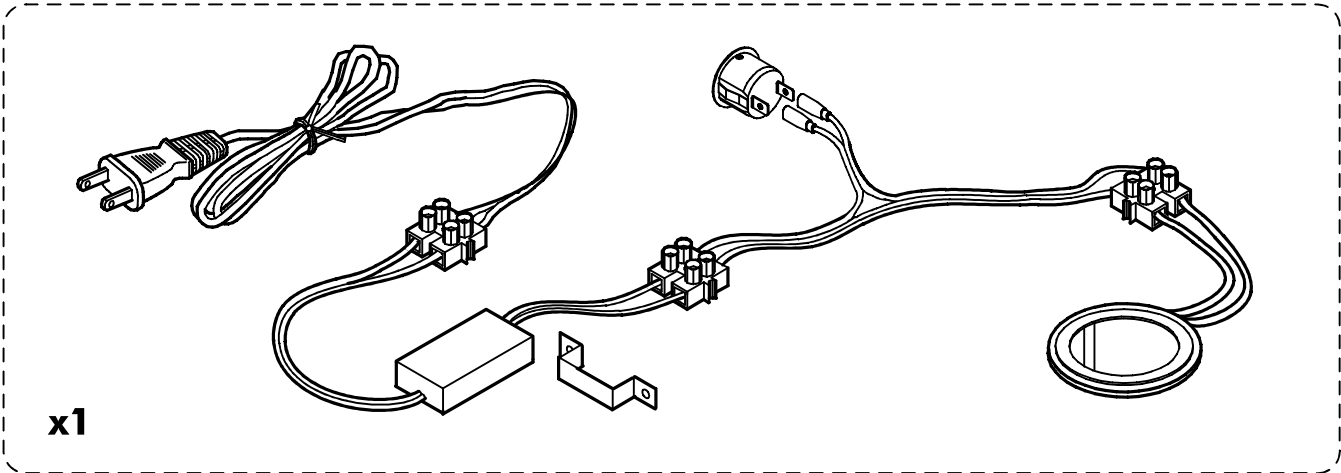

**x1**

1.

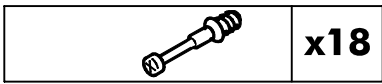
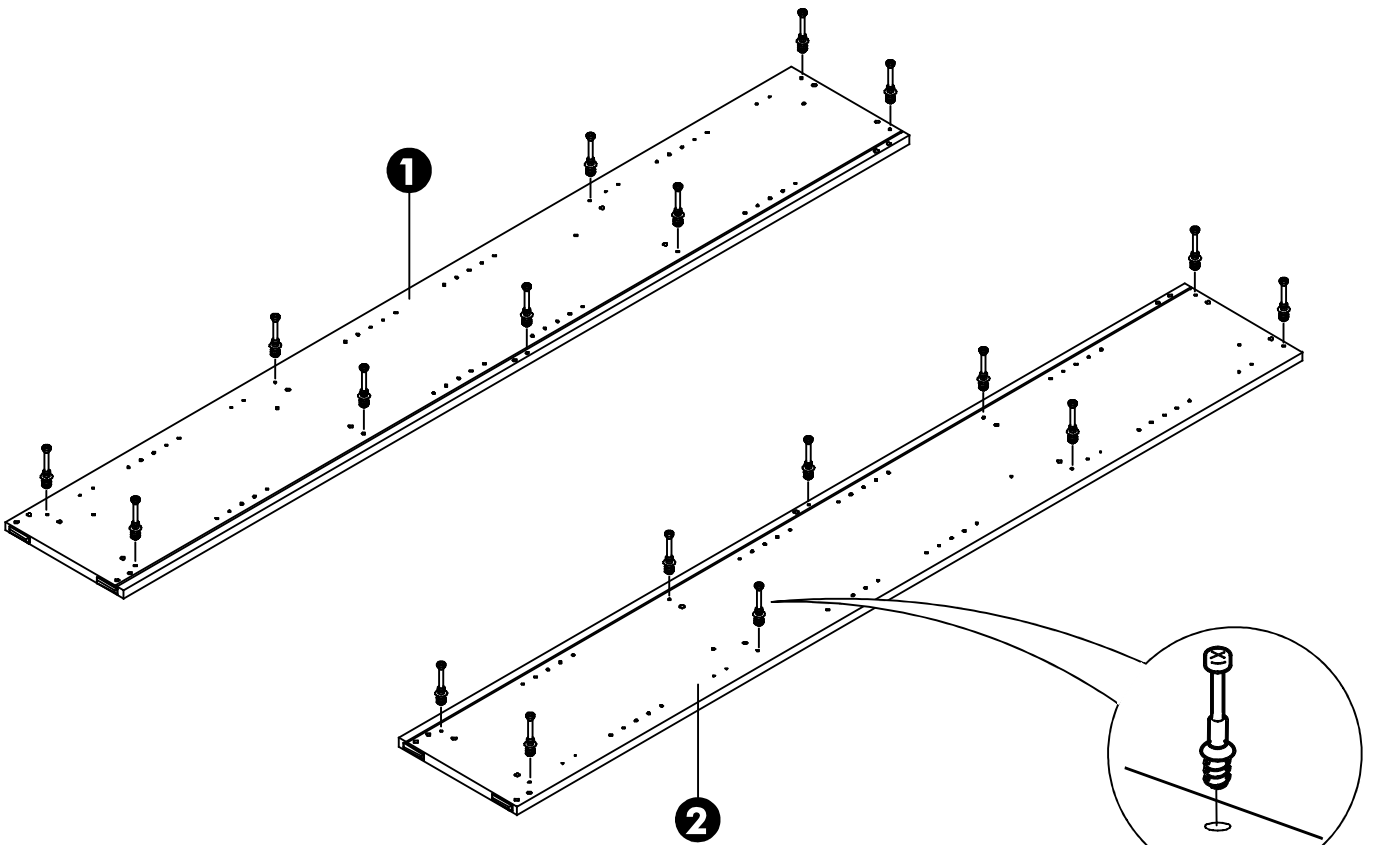

2.

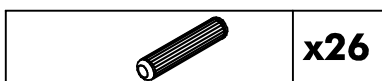
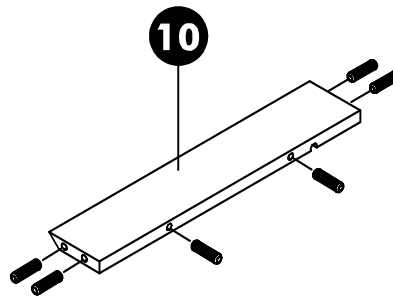
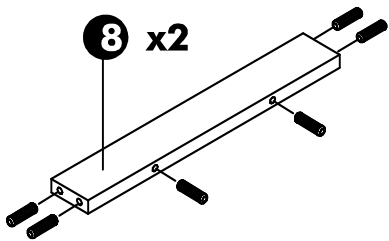
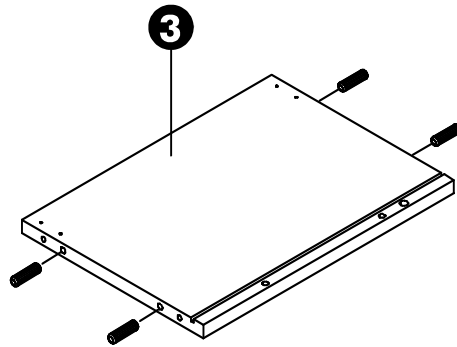
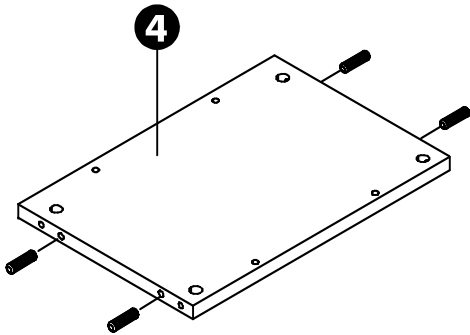

3.

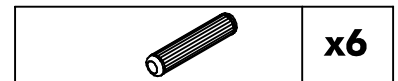
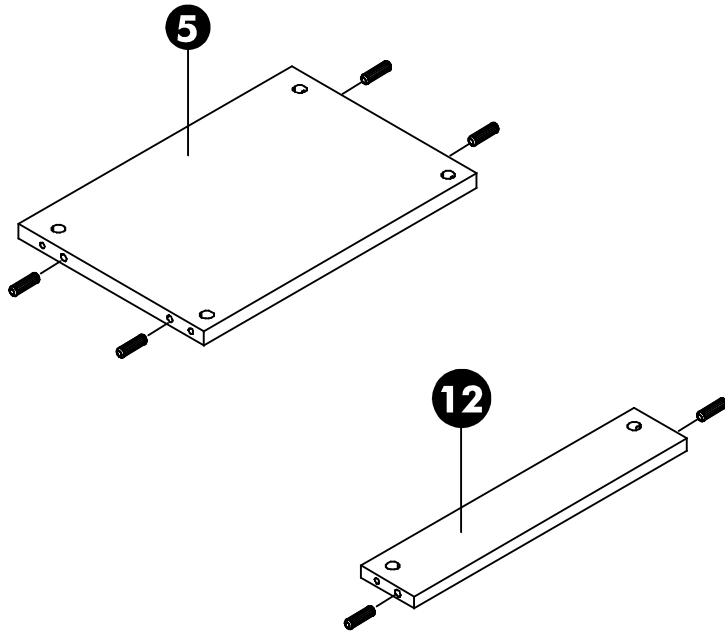

4.

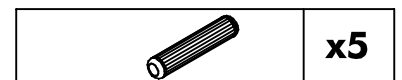
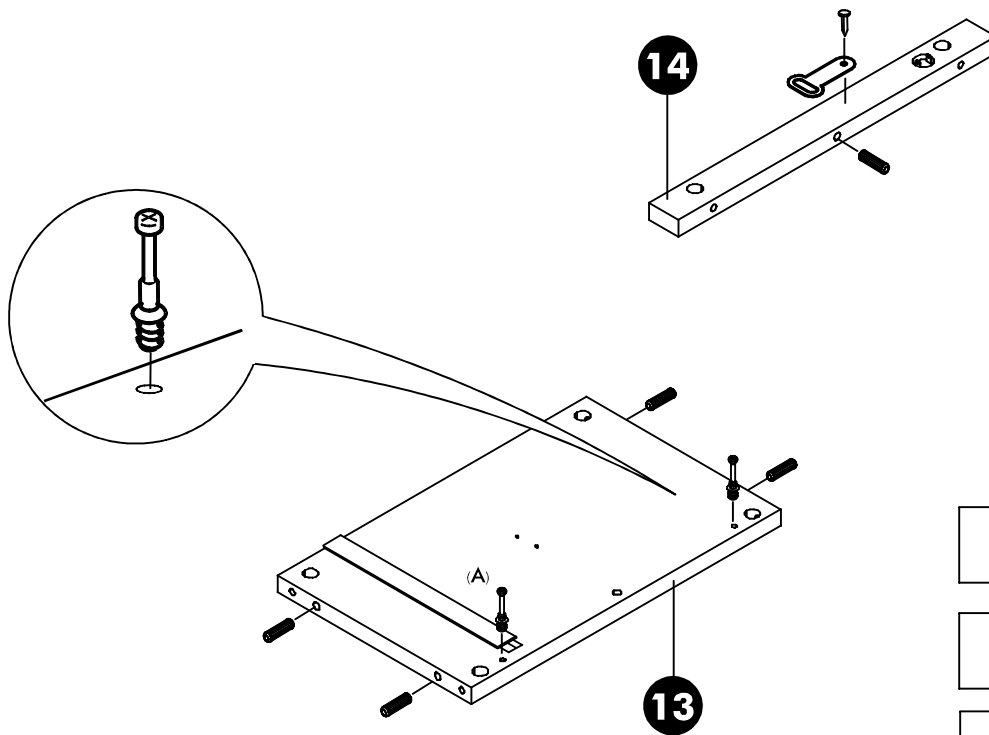

5.

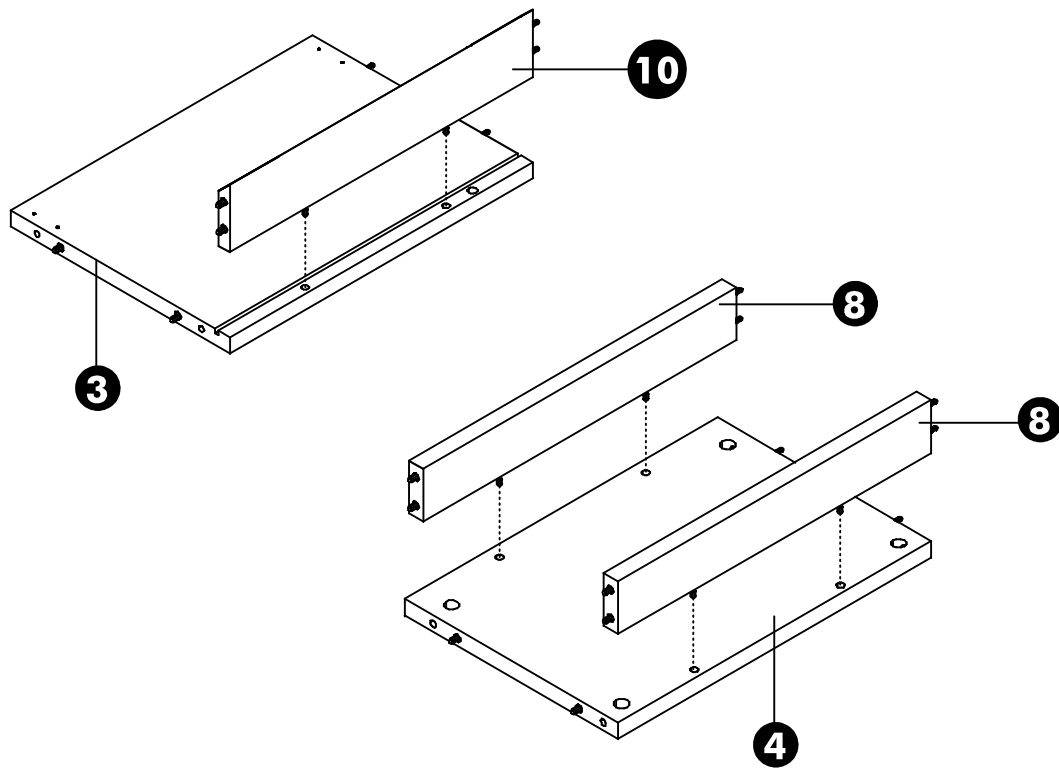

6.

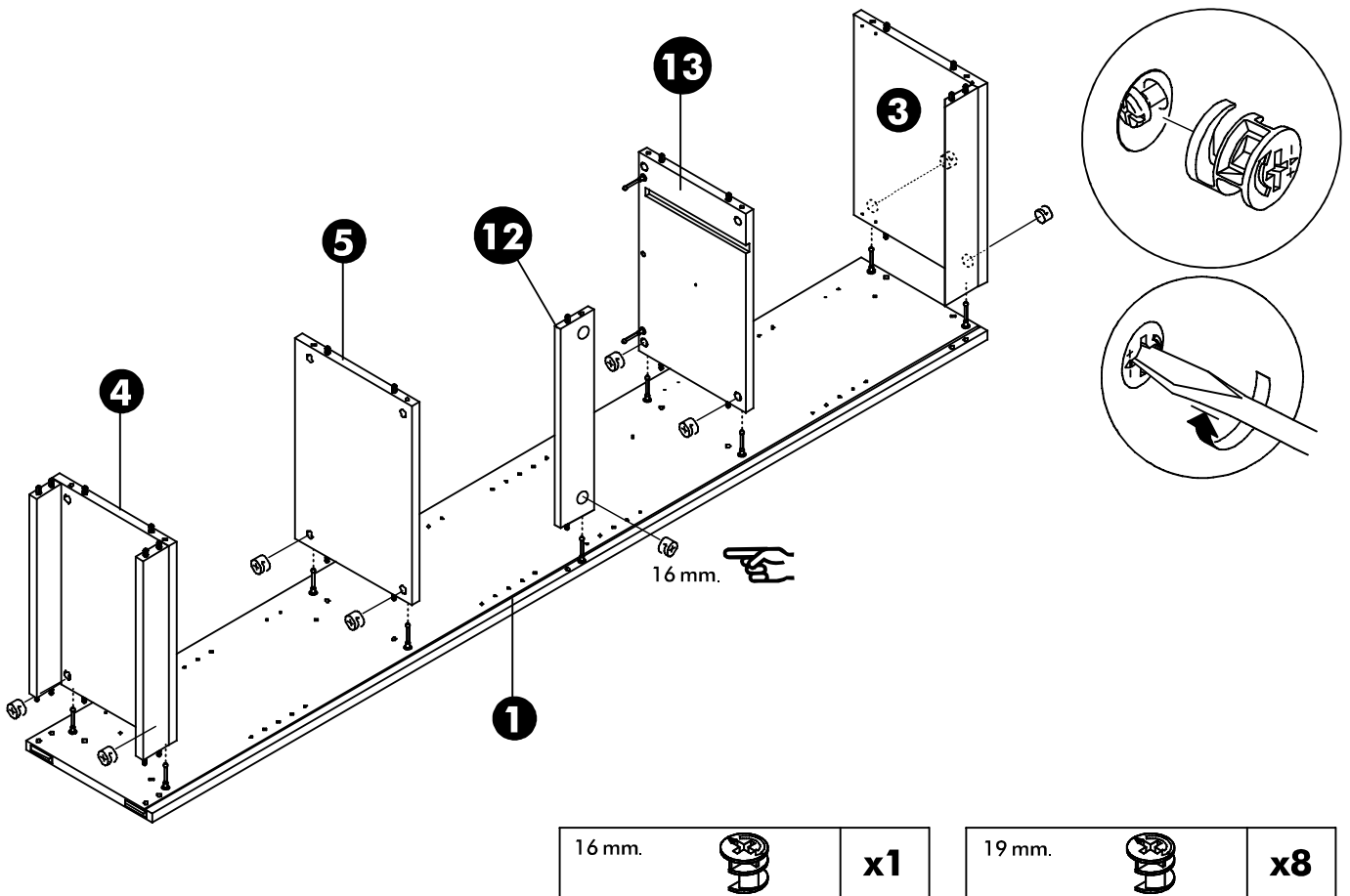

7.

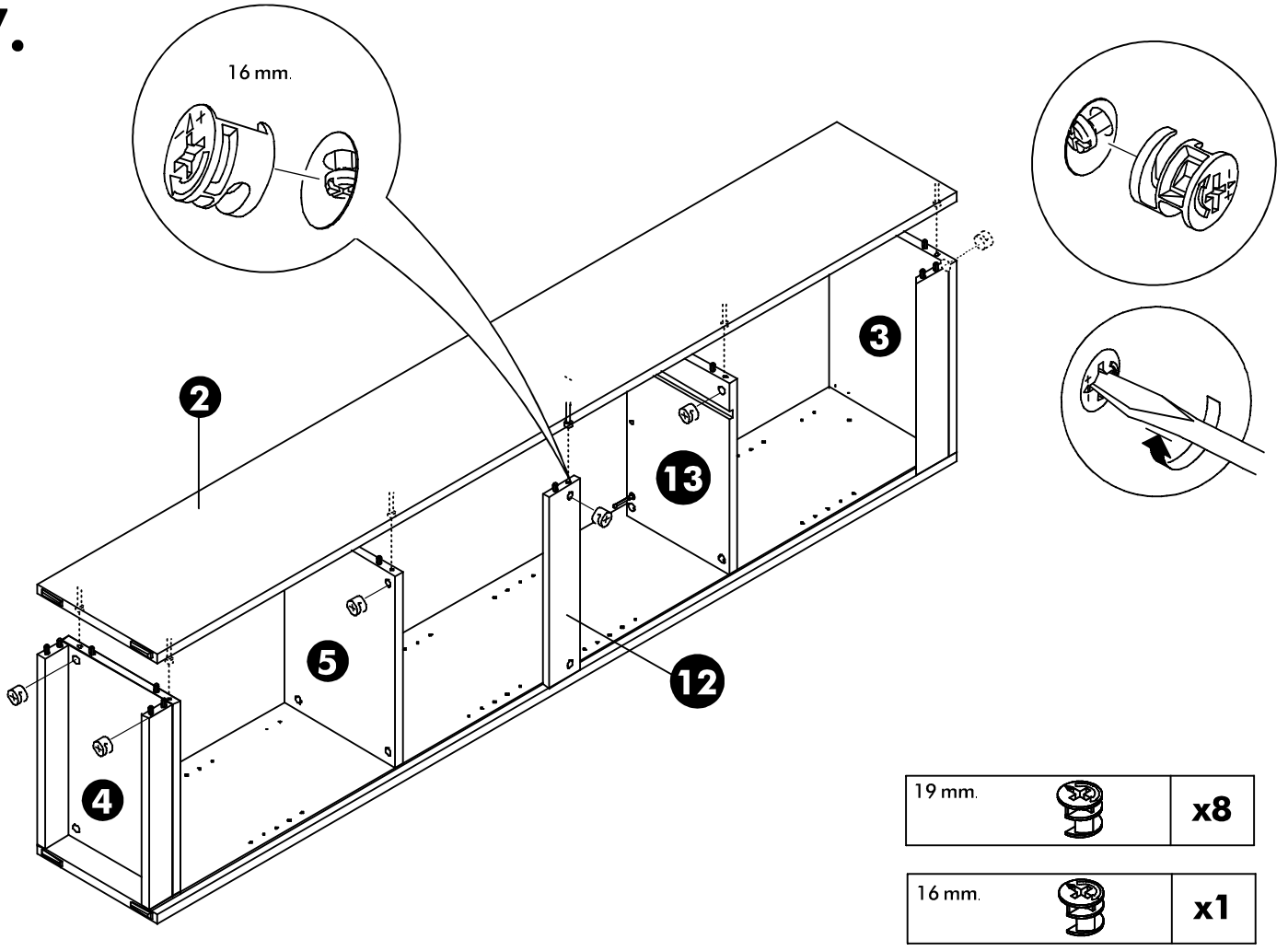

8.

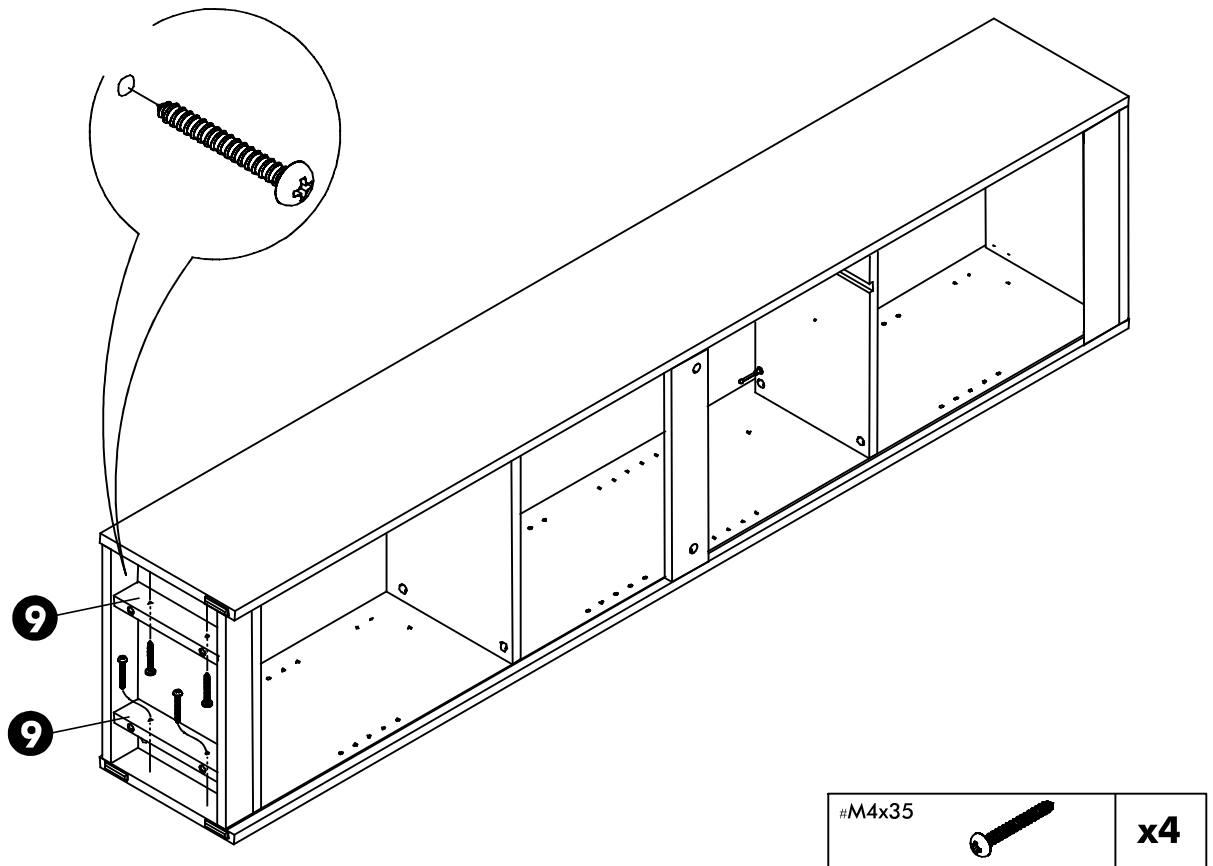

9.

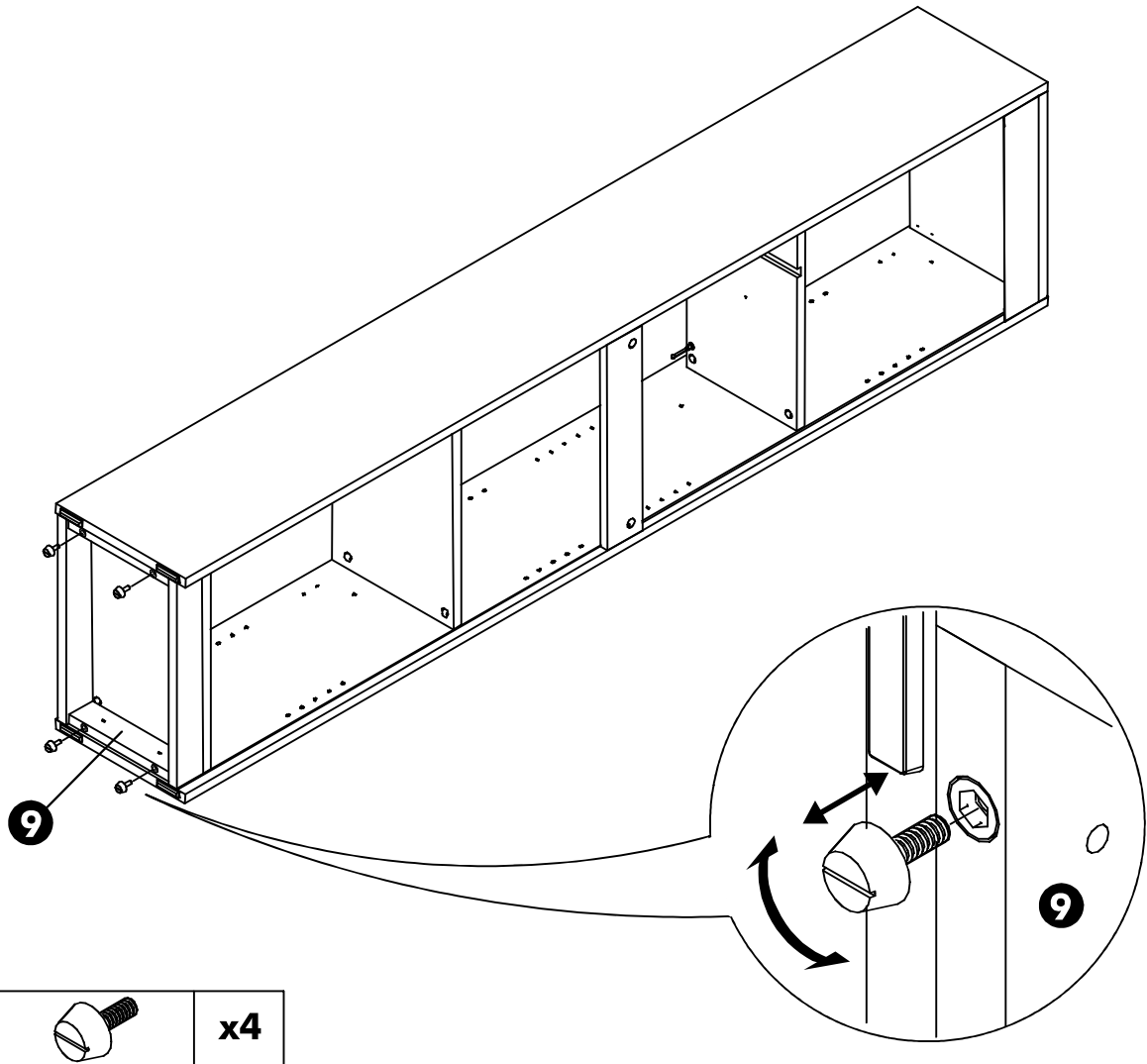

10.

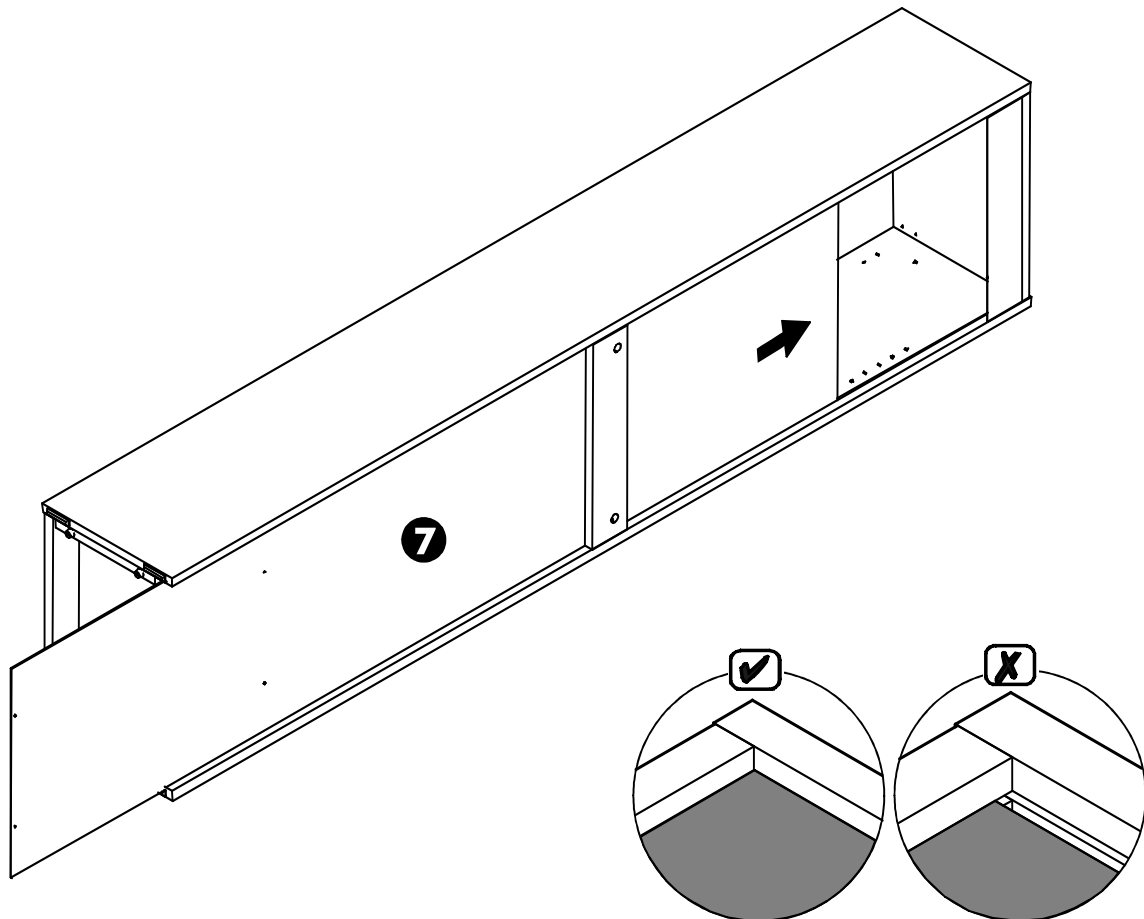

# 11.

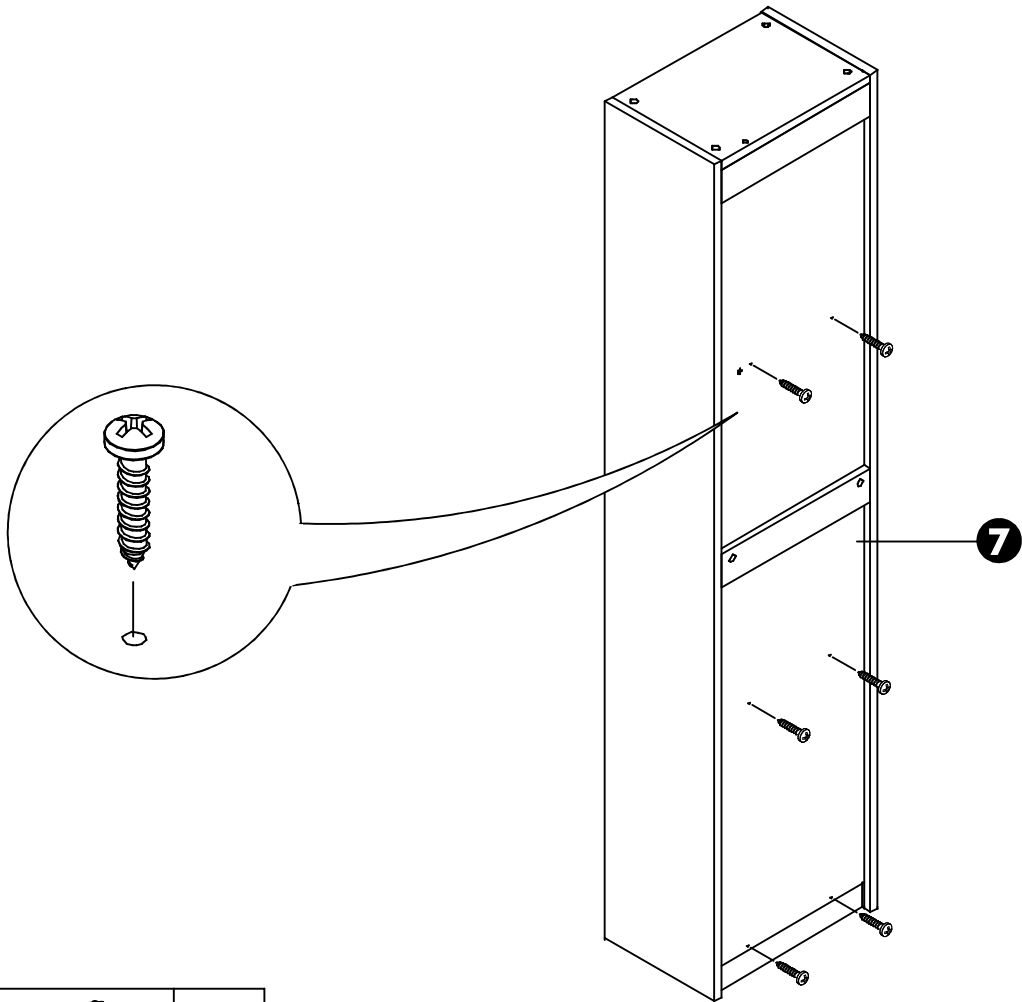

# 12.

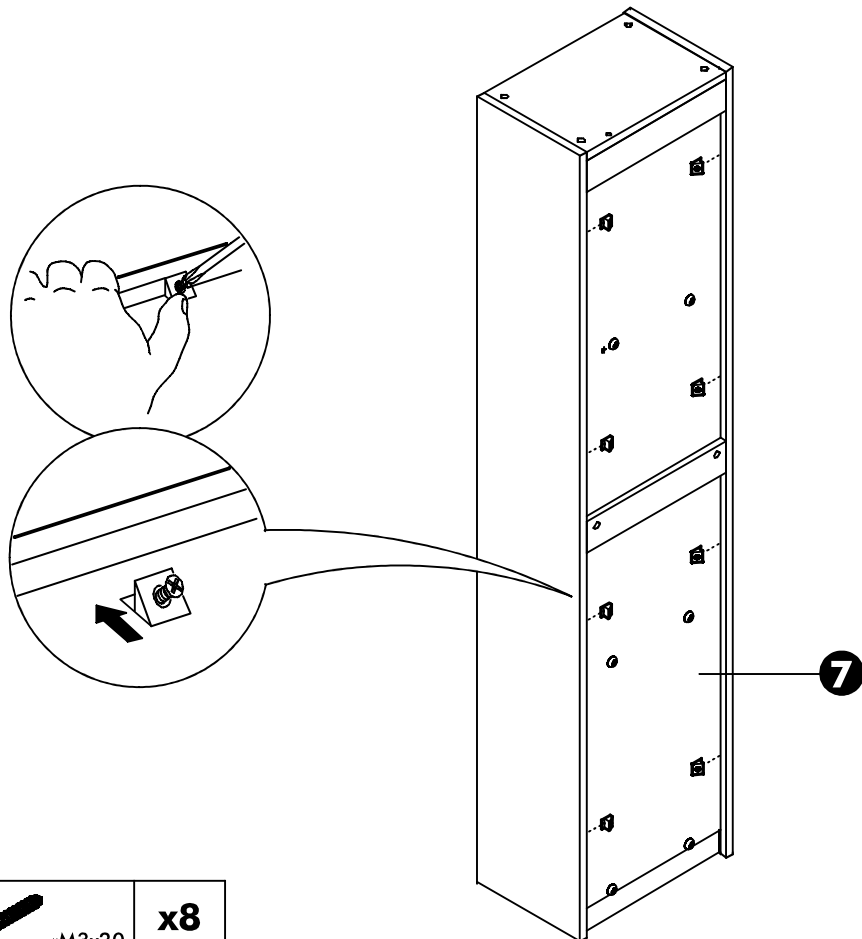

# 13.

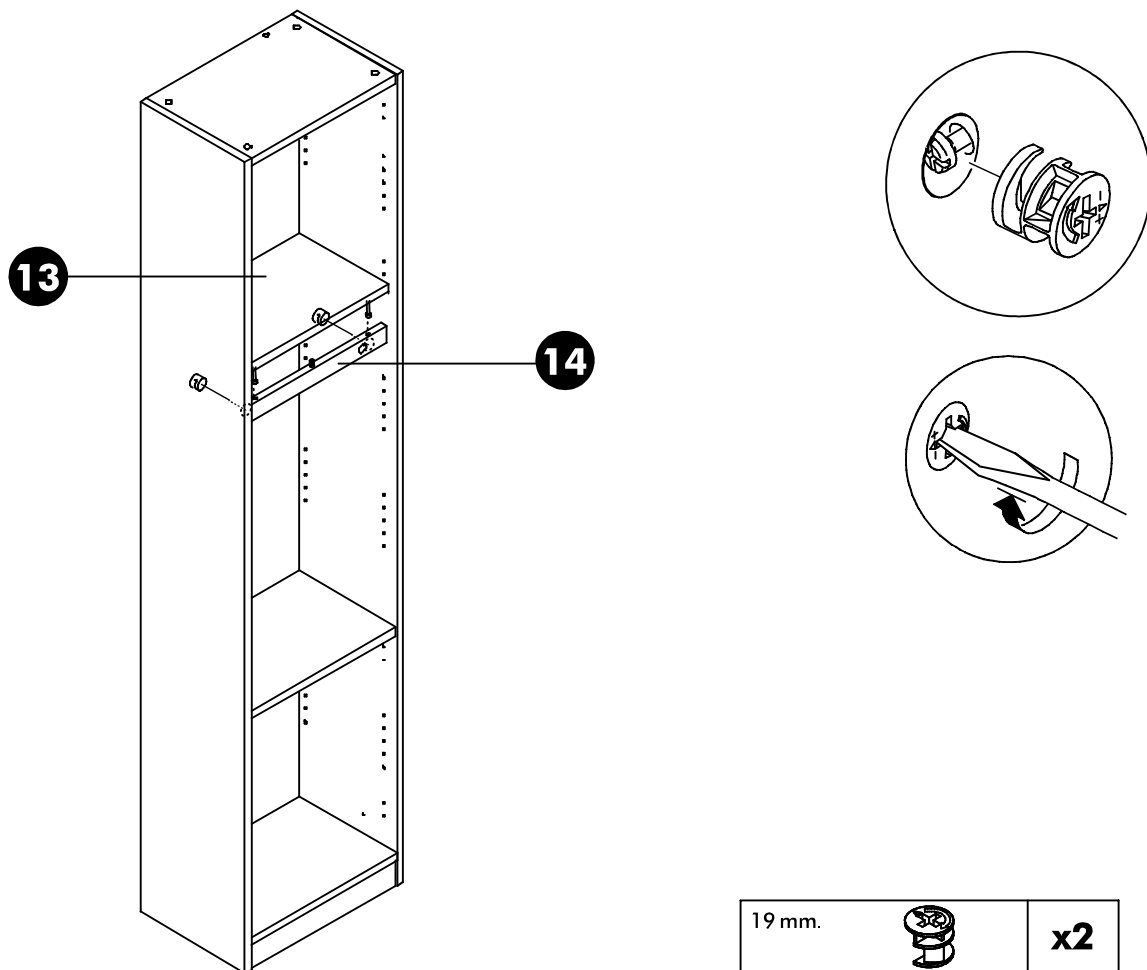

# 14.

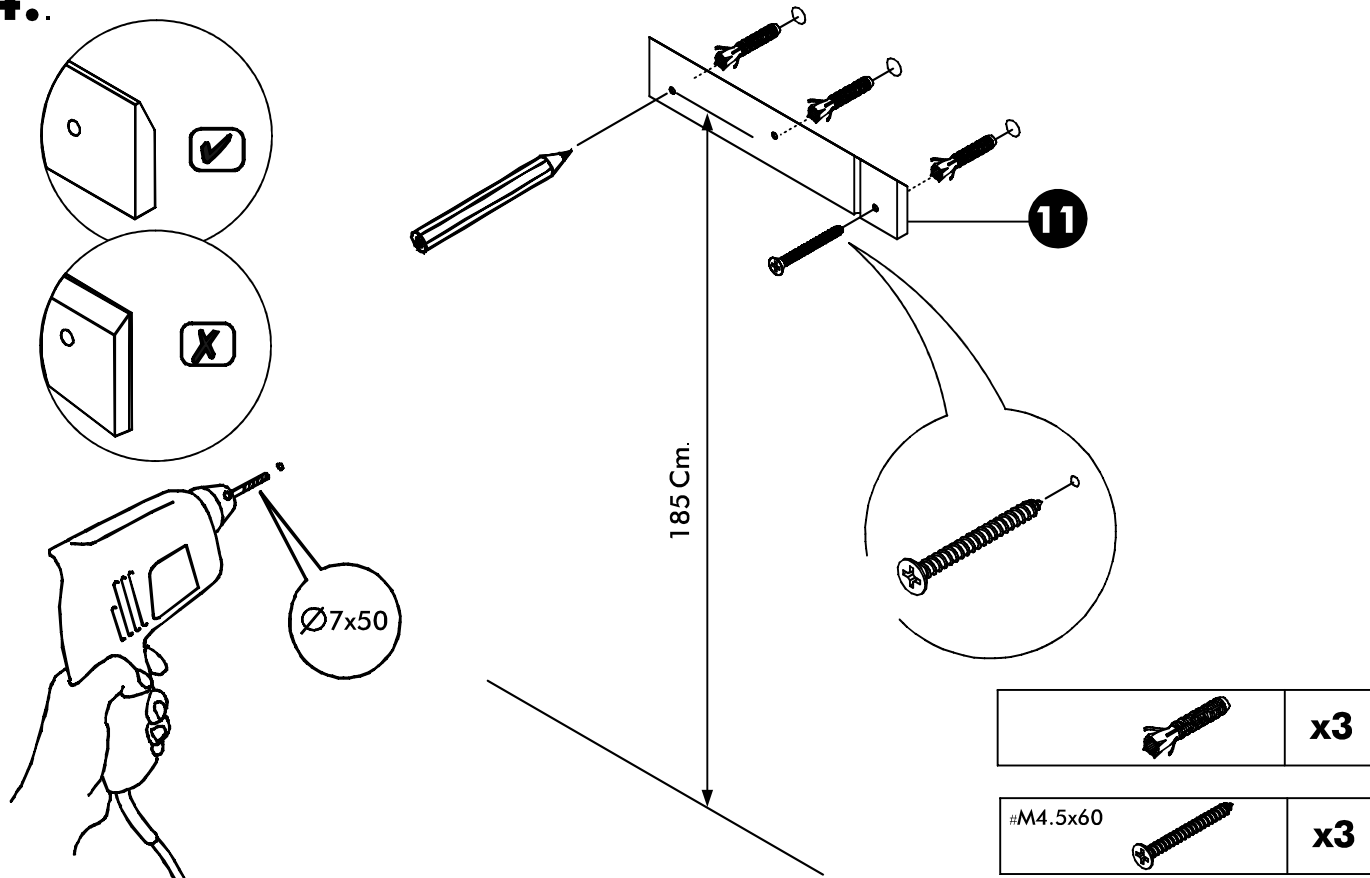

# 15.

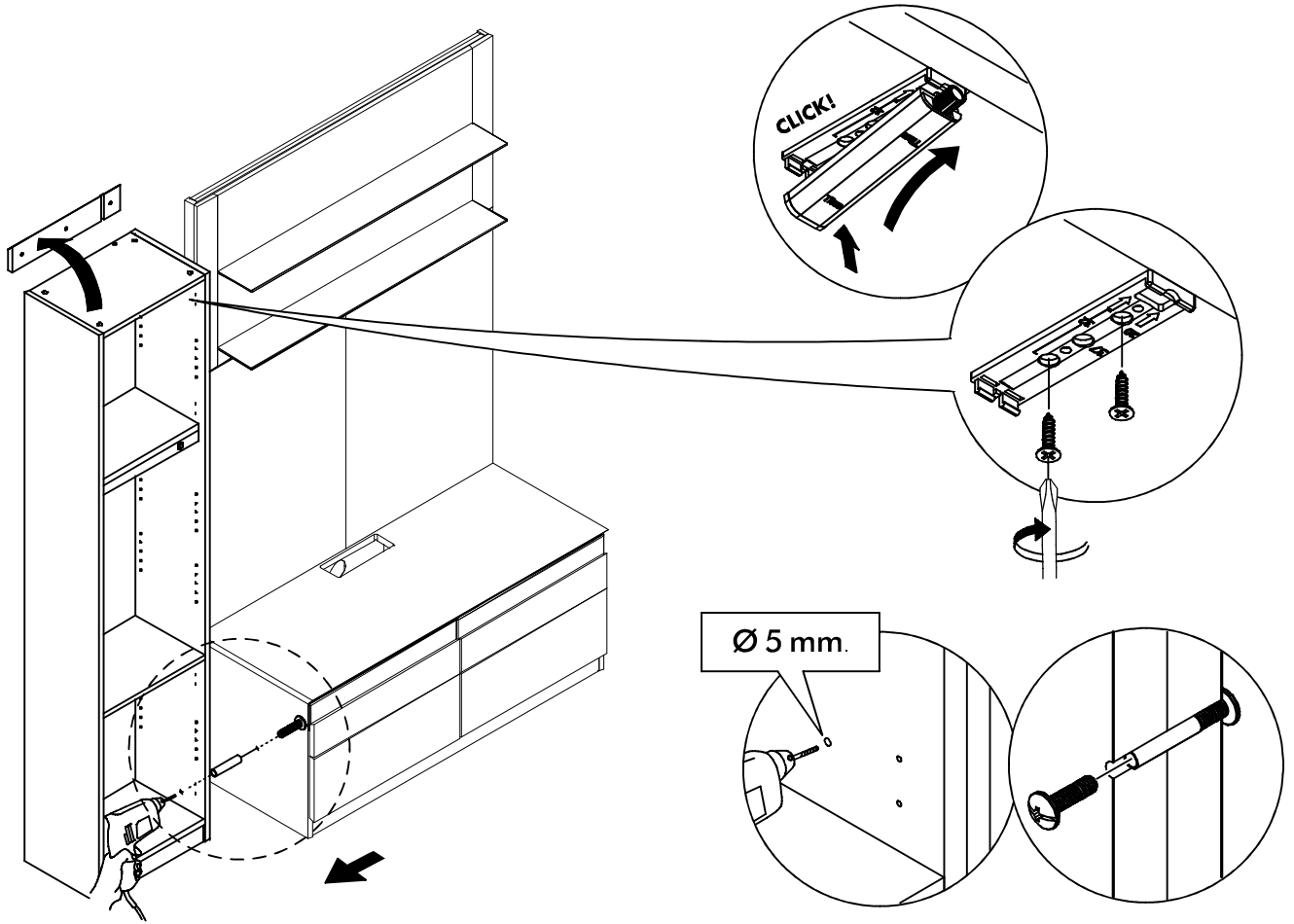

# 16

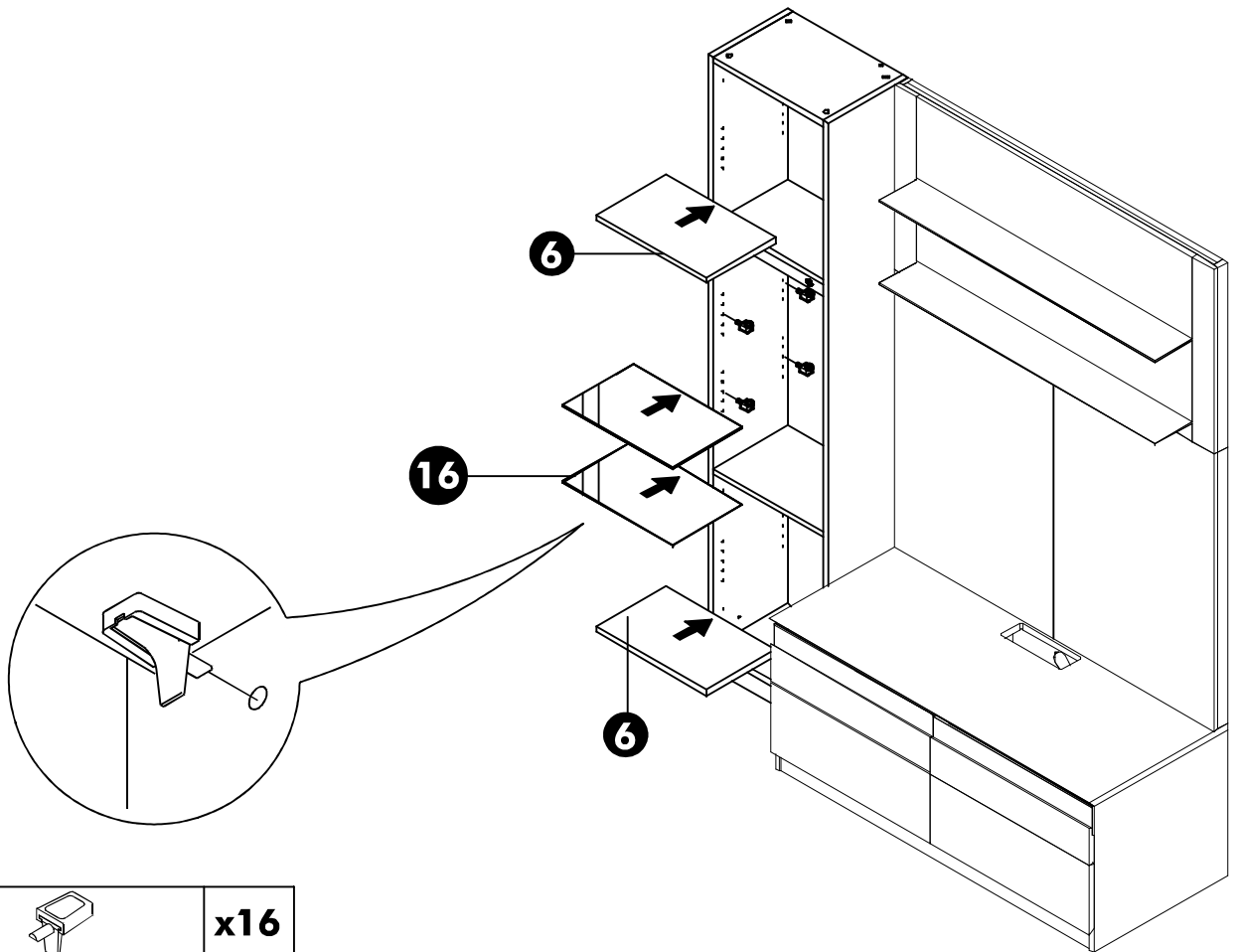

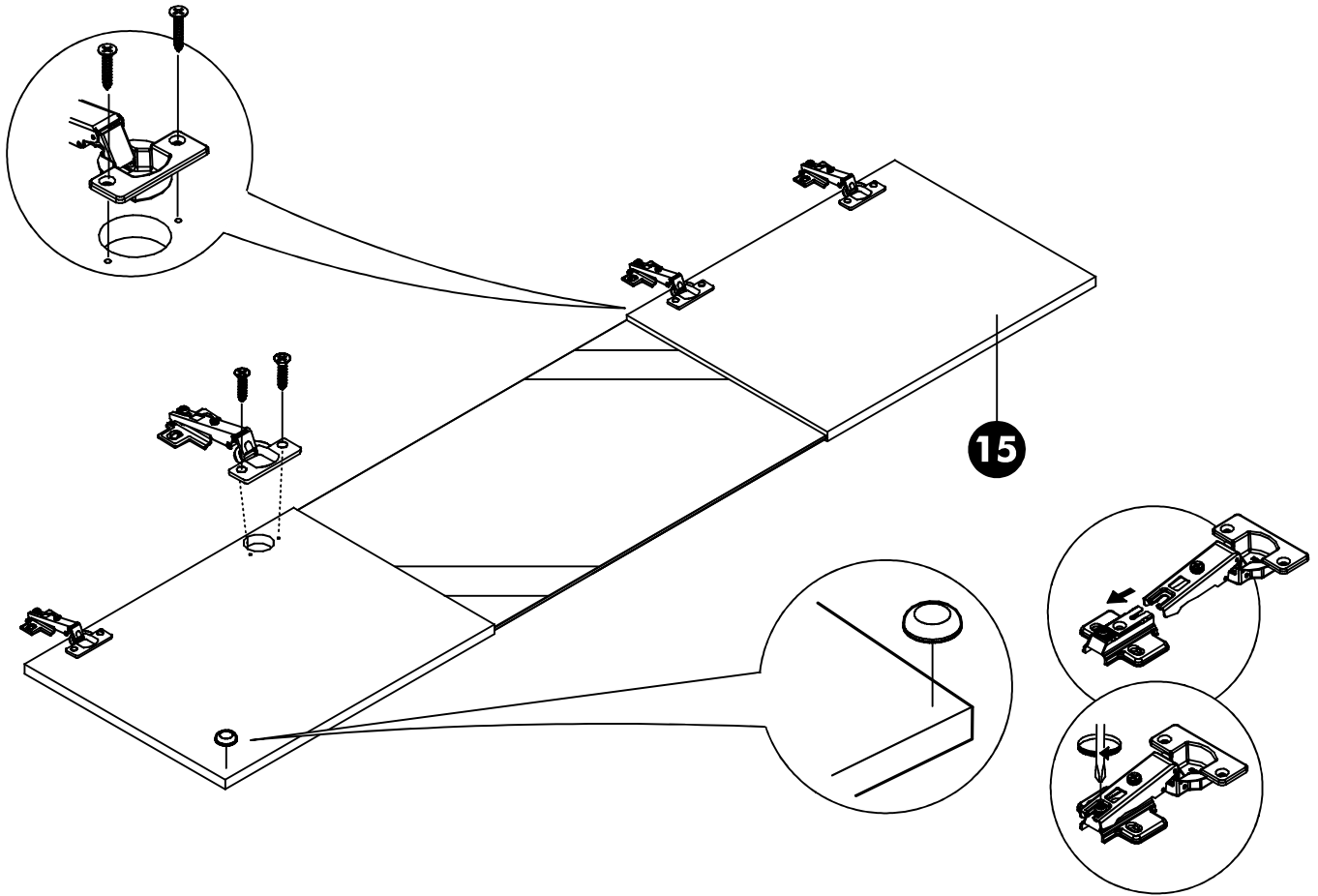

17.

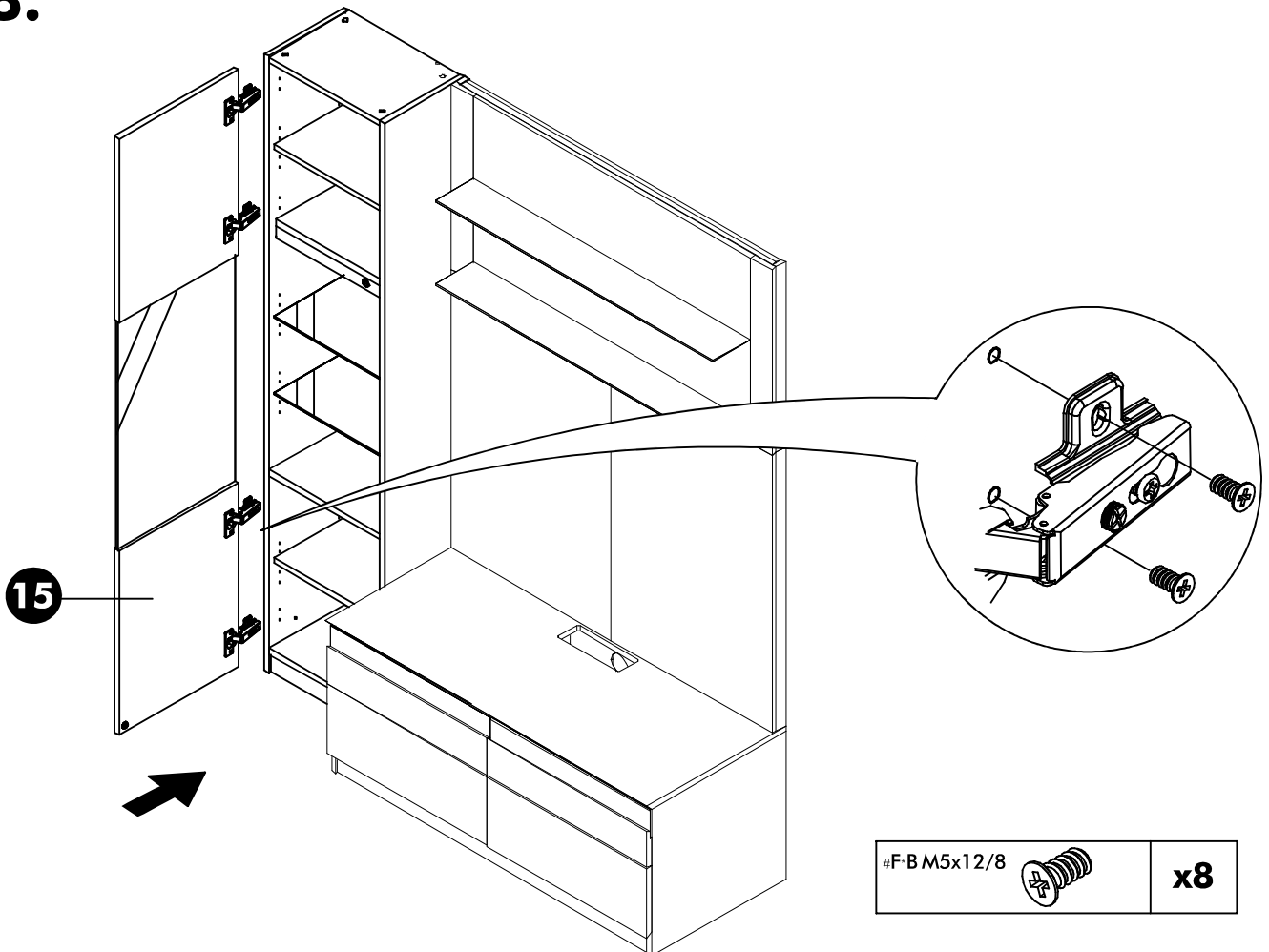

	<b>x4</b>	#M4x16		<b>x8</b>		<b>x1</b>
---	-----------	--------	---	-----------	---	-----------

18.



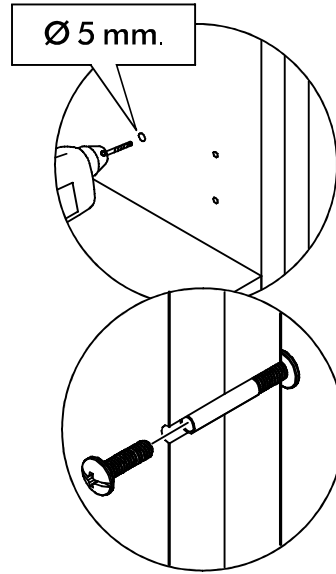
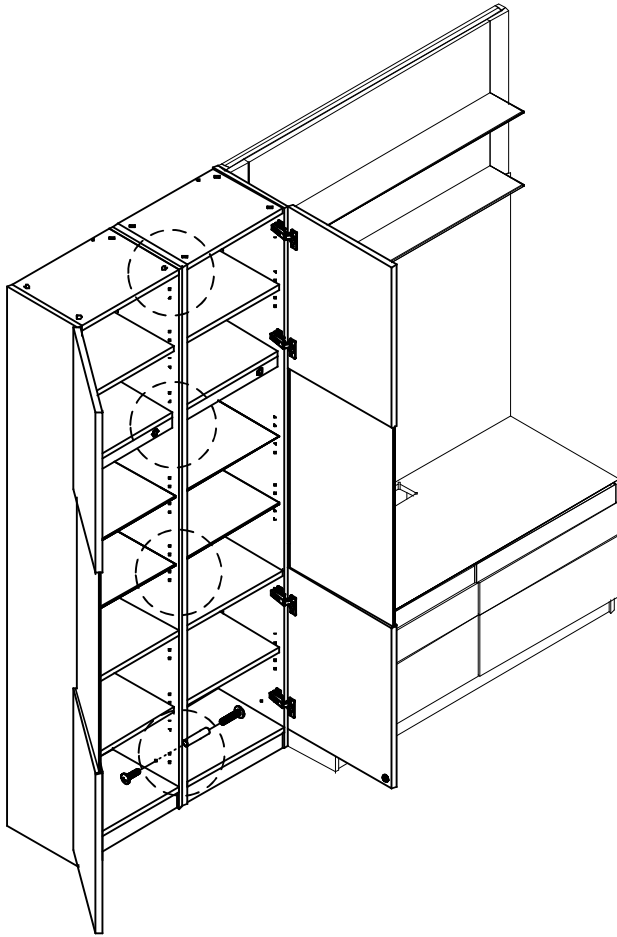

#F-B M5x12/8		<b>x8</b>
--------------	---	-----------



Ø 5 mm.

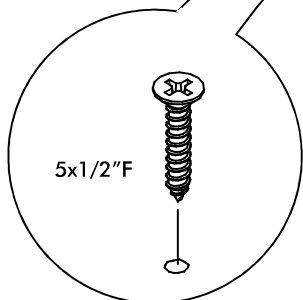
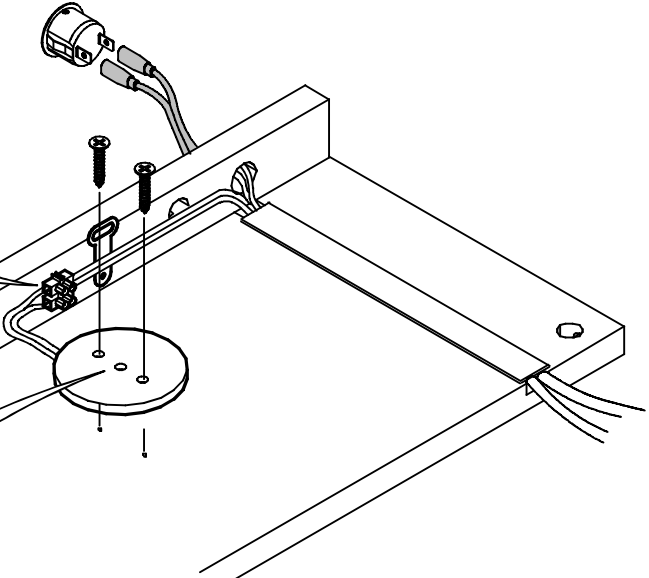
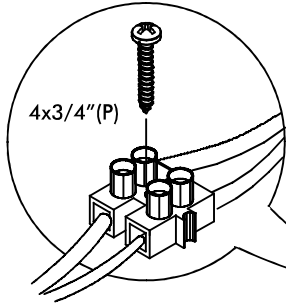
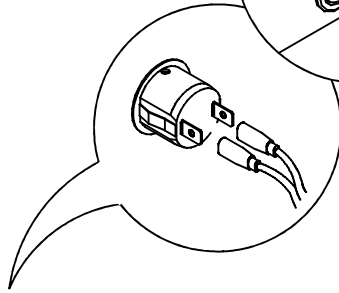
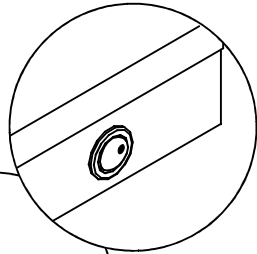
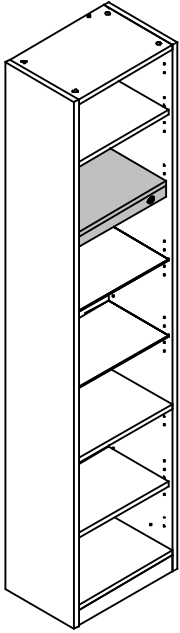
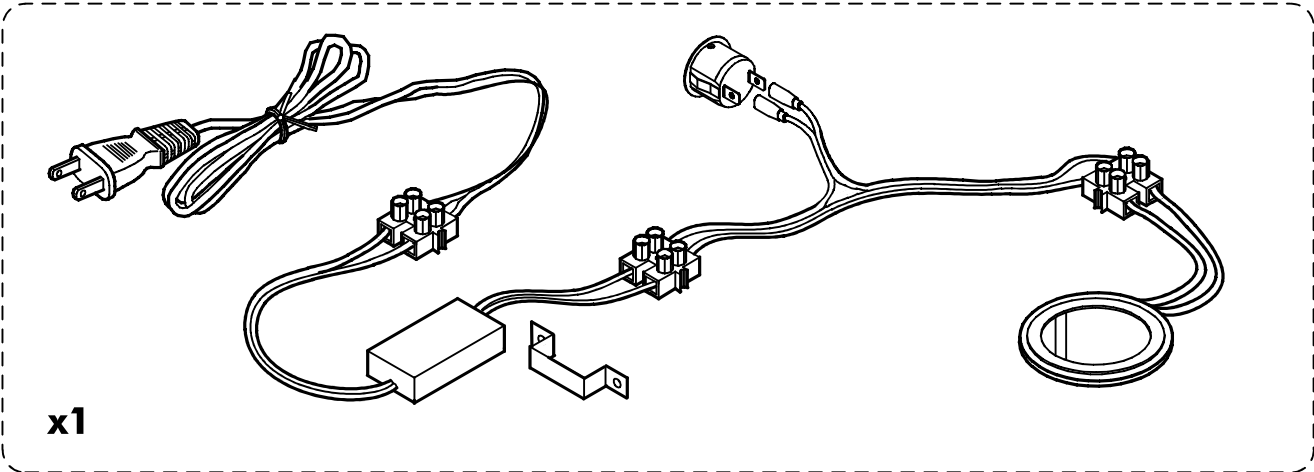



4x3/4"(P)		<b>x1</b>
-----------	---	-----------

5x1/2"F		<b>x2</b>
---------	---	-----------

